



FERRARI

312 T4

THE LEGENDARY 1970s F1 FERRARI

PACK **10**

STAGES 83-92



SCALE
1:8

AGORA
MODELS®



FERRARI

312 T4

SCALE
1:8

Contents

STAGE 83	
FIRST LEFT EXHAUST MANIFOLDS	1
STAGE 84	
EXHAUST MANIFOLDS	5
STAGE 85	
FIRST RIGHT EXHAUST MANIFOLDS	9
STAGE 86	
LAST EXHAUST MANIFOLDS	13
STAGE 87	
EXHAUST PIPES	17
STAGE 88	
COCKPIT LEFT BELLY	21
STAGE 89	
COCKPIT RIGHT BELLY	25
STAGE 90	
RIGHT BOTTOM BELLY	29
STAGE 91	
LEFT BOTTOM BELLY	33
STAGE 92	
LEFT SKIRT AND BULKHEAD	37

© Agora Models

AGORA
MODELS

WARNING: NOT SUITABLE
FOR CHILDREN UNDER THE
AGE OF 14. THIS PRODUCT IS
NOT A TOY AND IS NOT
DESIGNED OR INTENDED
FOR USE IN PLAY.
ITEMS MAY VARY FROM
THOSE SHOWN.

Produced under license of Ferrari S.p.A.
The name FERRARI, the PRANCING HORSE
device, all associated logos and distinctive
designs are property of FERRARI S.p.A.
The body designs of the Ferrari cars are
protected as Ferrari S.p.A. property under
design, trademark and trade dress regulations.

FIRST LEFT EXHAUST MANIFOLDS

STAGE 83 INCLUDES THE FIRST EXHAUST MANIFOLDS FOR THE LEFT BANK OF THE ENGINE. ASSEMBLE THESE BY FOLLOWING THE INSTRUCTIONS BELOW.

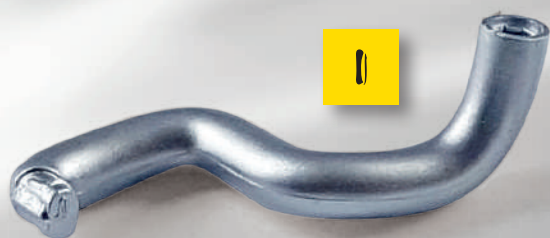

1



2



3



4

LIST OF PARTS

- 1 Manifold A
- 2 Manifold B
- 3 Manifold C
- 4 Exhaust pipe support fitting



01

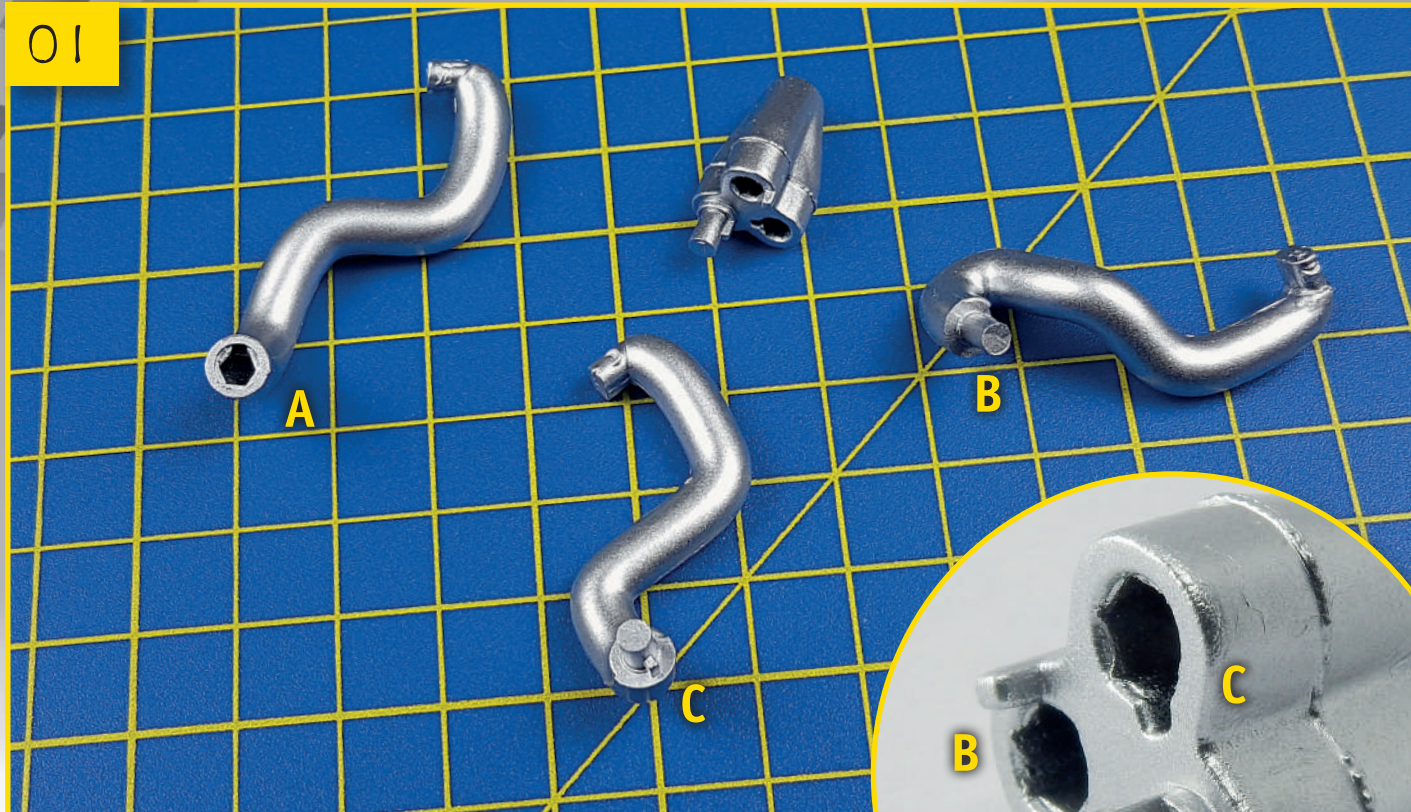

83-01 Place all the exhaust parts on your work surface. The images show the joints that will be used for assembling these pieces together.

02

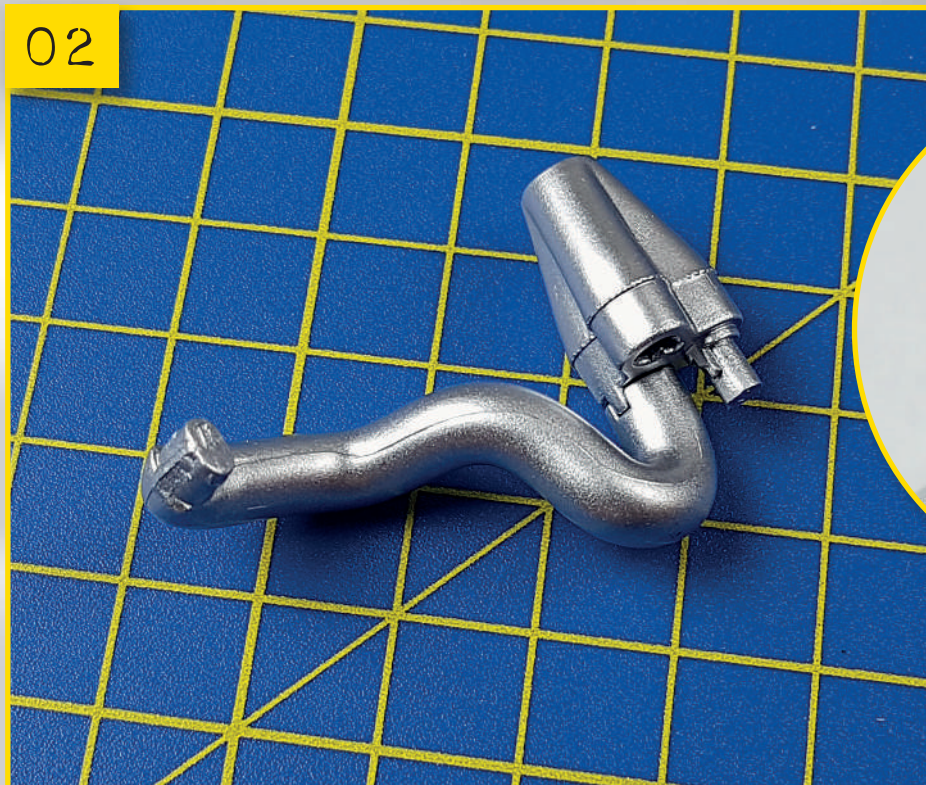

83-02
Take the manifold B and insert it into the connector on the fitting. Use the recess as a guide (inset, arrow).



83-03

Take the manifold C and insert it into the connector on the fitting in the same way

03

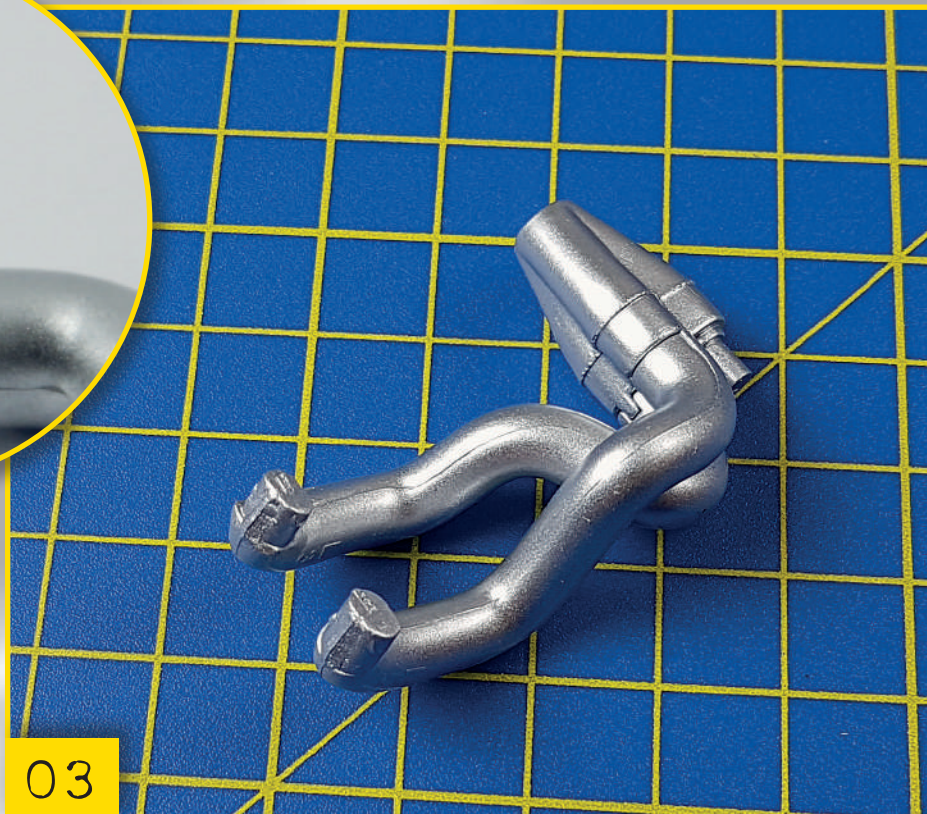

83-04

Press the hole in manifold A onto the fitting pin. The hole has an alignment tooth to guide the direction of the part.

04



05



83-05

Make sure all three fittings have been installed correctly. Their free ends must be aligned as shown.

FINAL RESULT

This is how the newly installed parts will look.



In the next stage

The next set of exhaust components.



EXHAUST MANIFOLDS

THIS STAGE COMES WITH THREE NEW EXHAUST MANIFOLDS AND THE RELEVANT FITTING FOR THE LEFT BANK OF THE ENGINE. TO ASSEMBLE THE PARTS, FOLLOW OUR INSTRUCTIONS AND THE EXPLANATORY PHOTOS THAT ACCOMPANY THEM.



1



2



4



5



3

4 type J screws



LIST OF PARTS

- 1 Manifold L5
- 2 Fitting part 1
- 3 Fitting part 2
- 4 Manifold L4
- 5 Manifold L6

SCREWS

Four type J screws



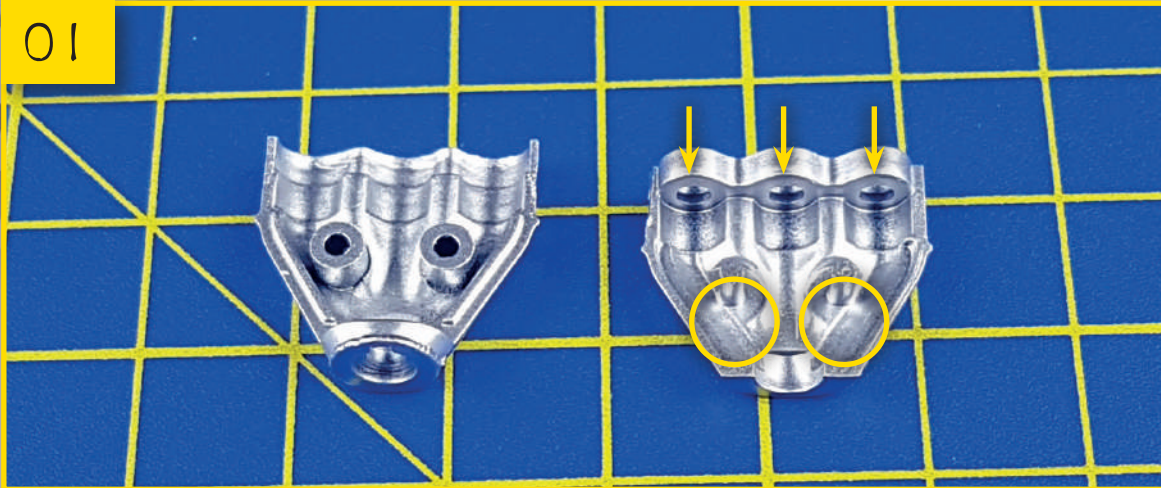

84-01 Take the two parts of the fitting. One of the two parts has two fixing pins (circled) and three holes (arrows). Put the other part to one side, to be used later.

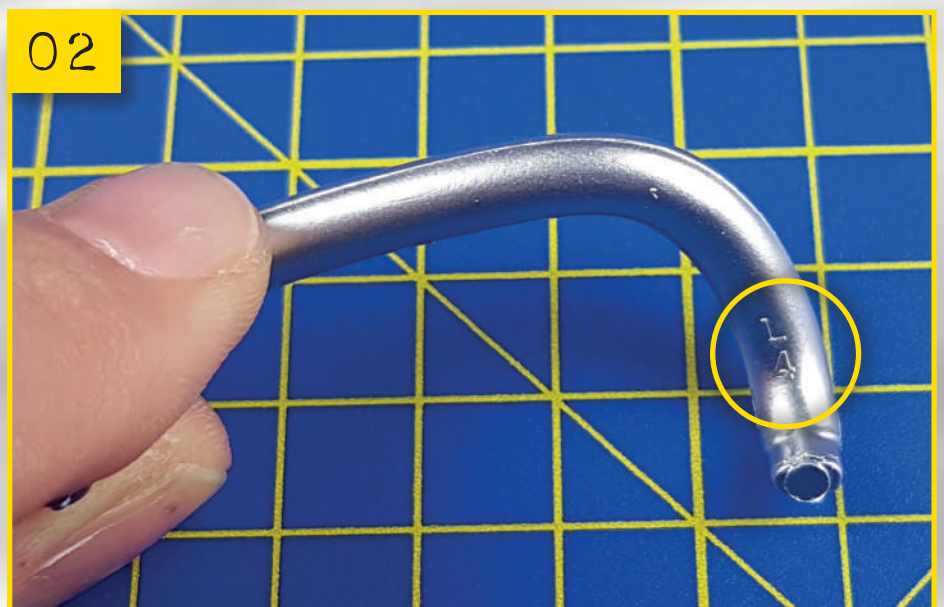

84-02 The different manifolds can be identified by the printed letter L ("left") and a number located on the side for connection to the engine. The manifolds supplied with this stage are numbered 4, 5, and 6 and are for the left bank of the engine.

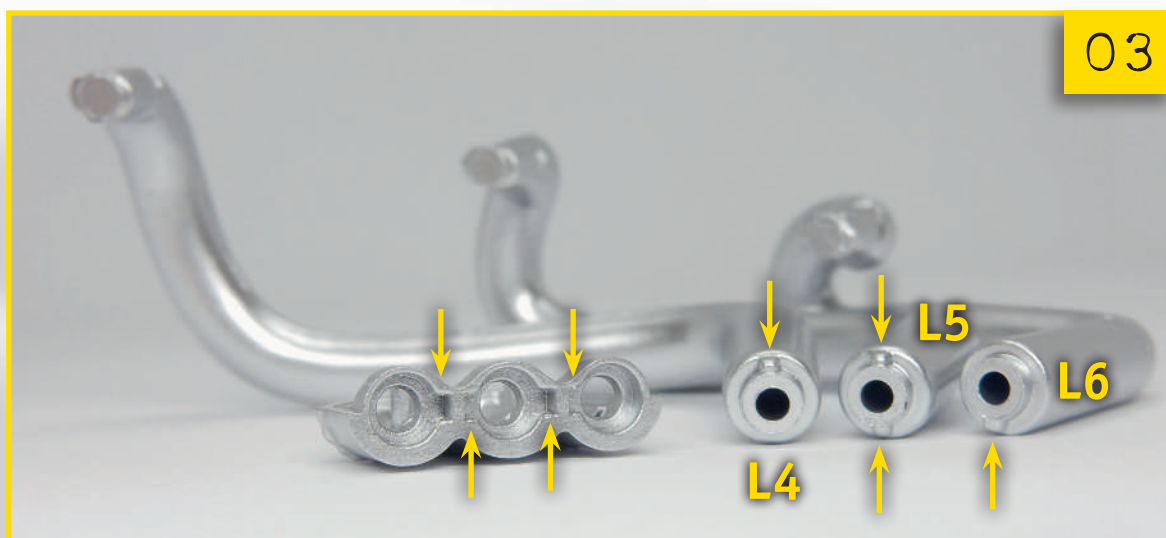

84-03 The manifolds have one or two teeth to ensure their correct position in the slots on the fitting.



84-04

Take the manifold L4 and fit it in place, then secure it with a type J screw.

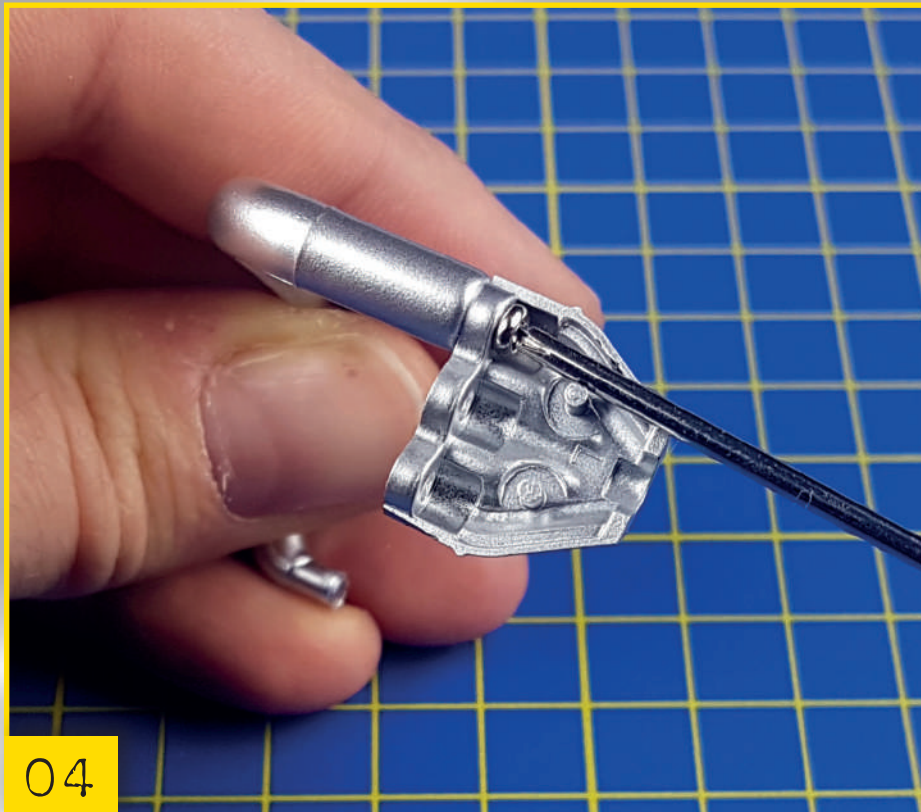

84-05

Do the same for manifold L5 into the centre hole, securing it with a type J screw.

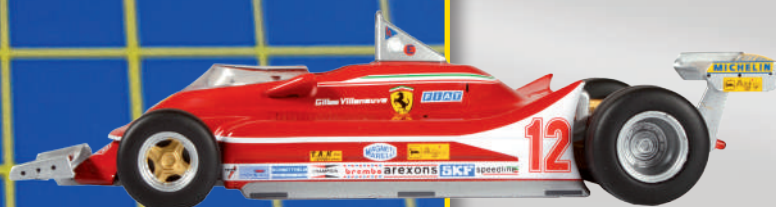

06

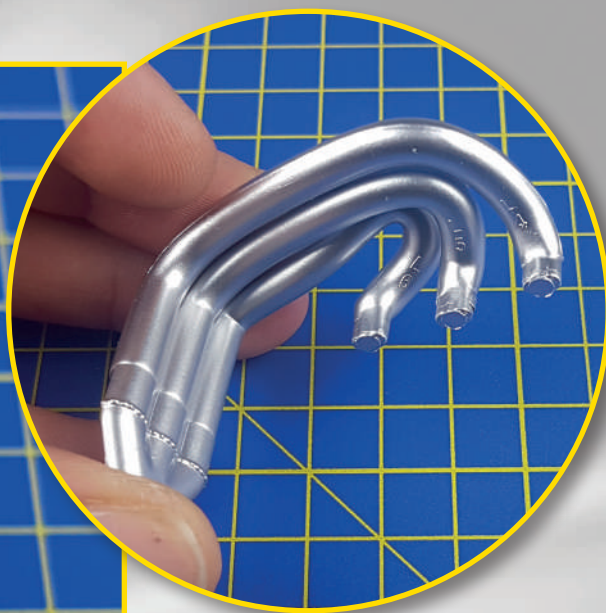
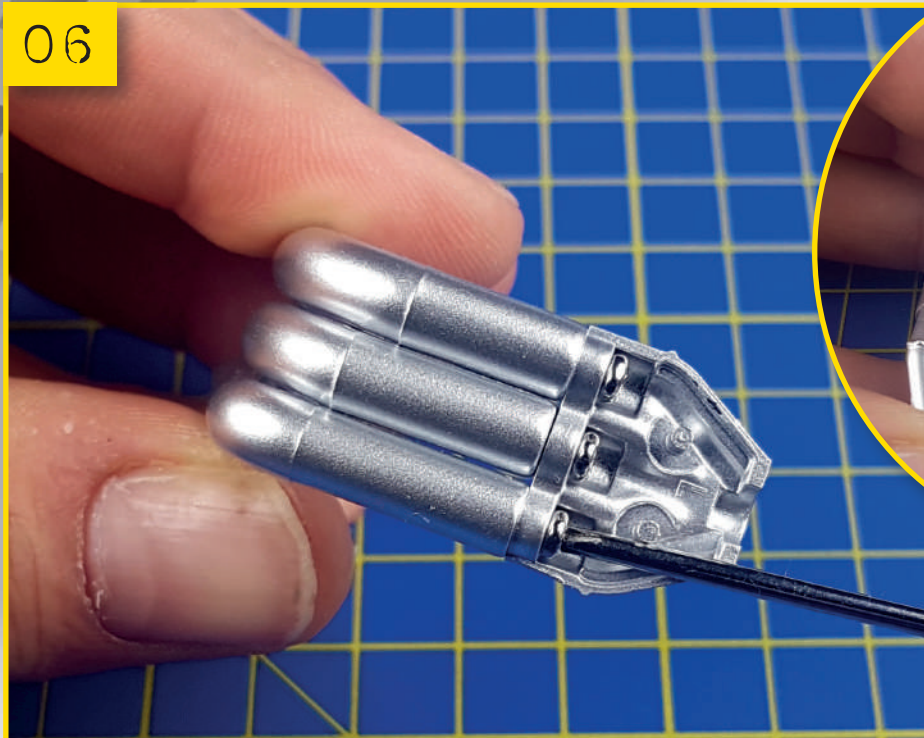

84-06 Secure the manifold marked number 6, with a type J screw. As you can see in the inset photo, once assembly is completed, the parts will be in the order L6, L5, L4, starting from the inside.



In the next stage

New parts of the engine exhaust system.



FINAL RESULT

This is how the three exhaust manifolds look when connected to their fittings.

FIRST RIGHT EXHAUST MANIFOLDS

THIS STAGE INCLUDES THE FIRST EXHAUST MANIFOLDS FOR THE RIGHT BANK AND THE RELEVANT FITTING. THESE ARE ASSEMBLED IN THE SAME WAY AS THE LEFT EXHAUST MANIFOLDS FROM STAGE 83.



LIST OF PARTS

- | | | | |
|---|------------------------------|---|-------------|
| 1 | Manifold R2 | 3 | Manifold R3 |
| 2 | Exhaust pipe support fitting | 4 | Manifold R1 |



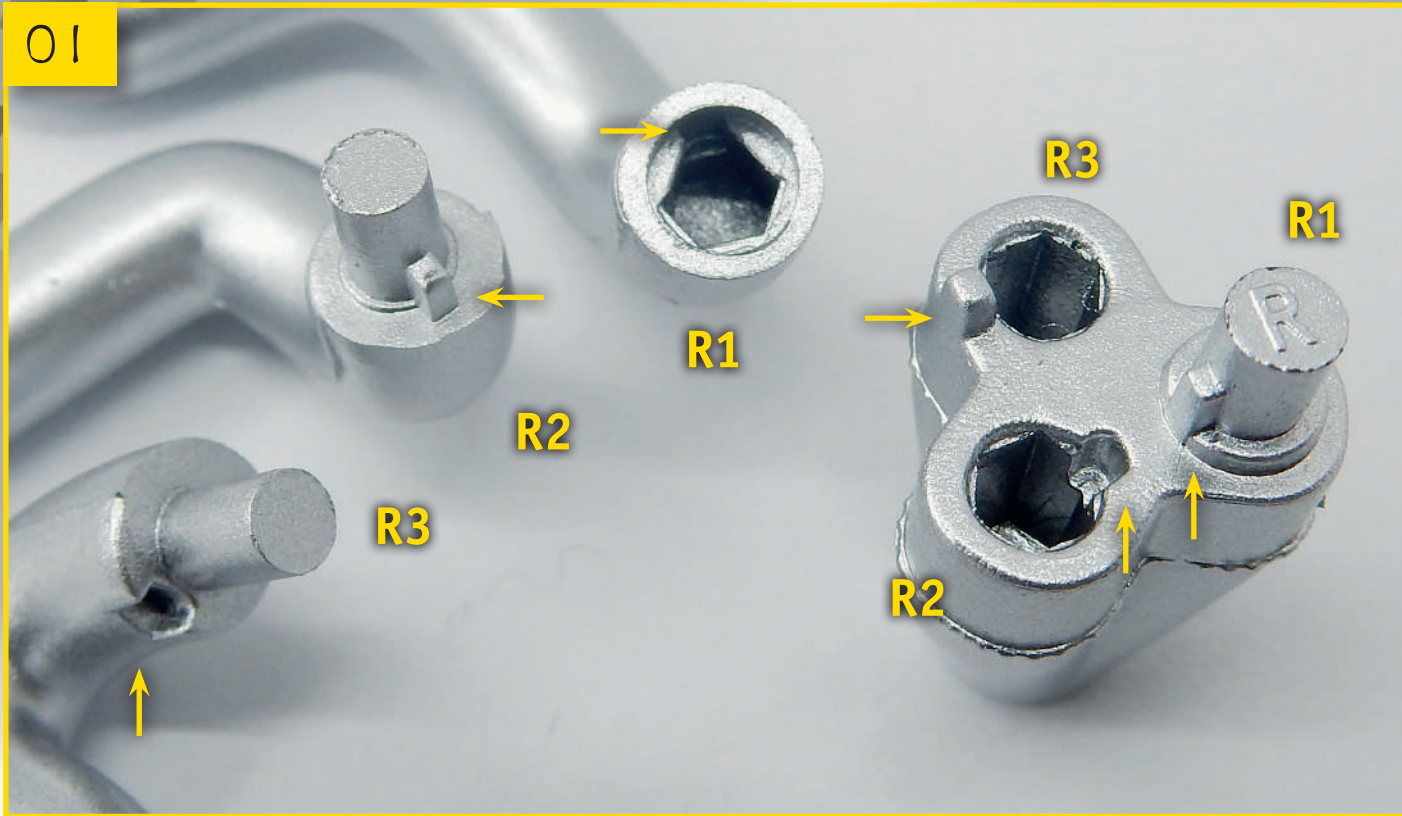

85-01 As you saw in stage 83, the fitting has three different joints and centring systems: a pin (manifold R1), a grooved hole (manifold R2) and a hole with projection (manifold R3).

85-02 Identify the manifold R2 and insert it into the pin coupling on the fitting, then press into place.

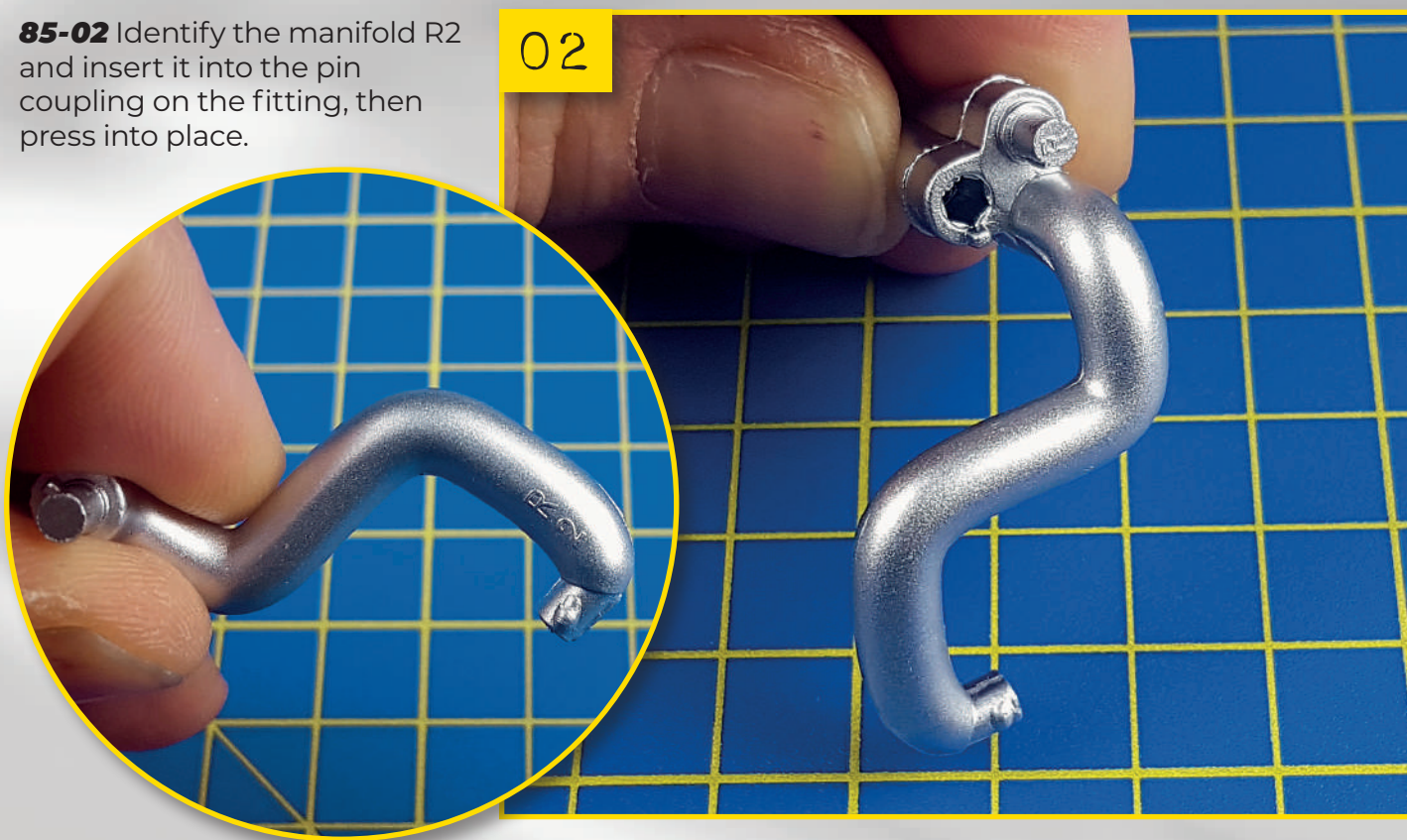

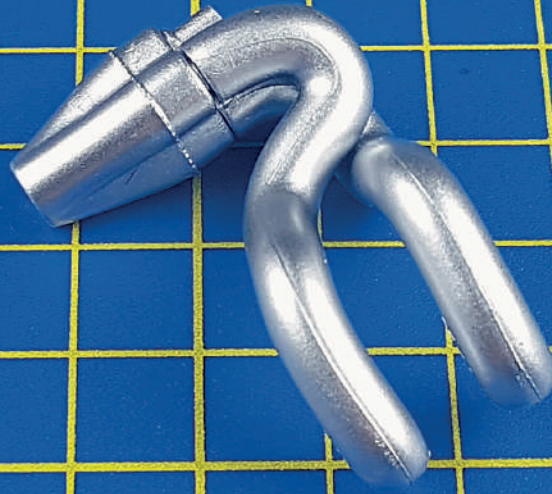
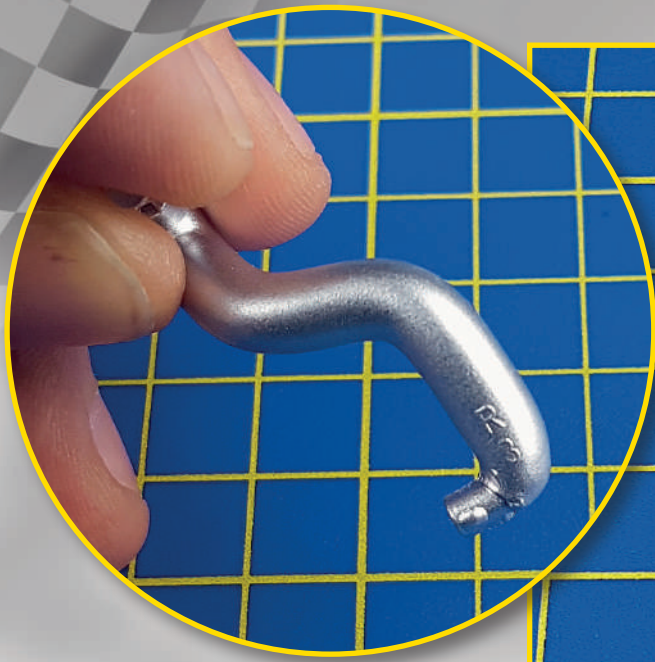

85-03 Identify the manifold R3, insert it into the joint and press into place.

03

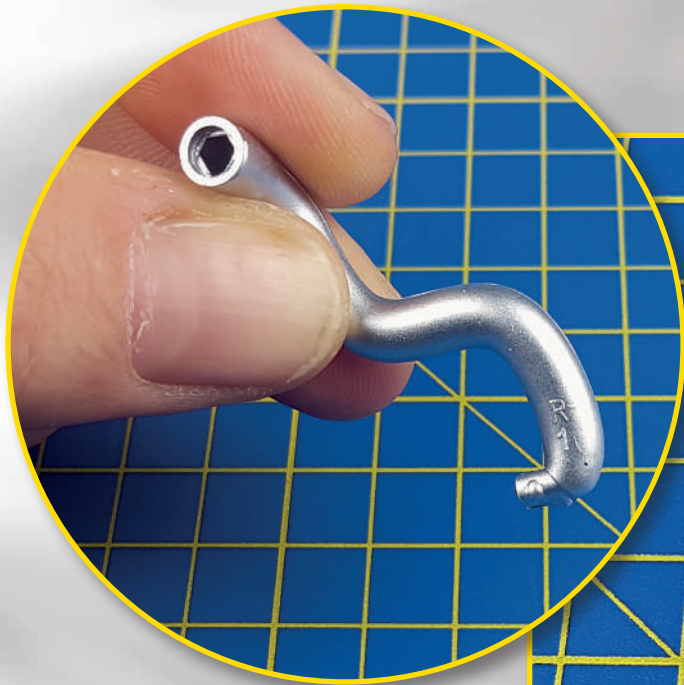

85-04 Lastly, identify and fit the manifold R1 on the fitting pin. The alignment tooth means the assembly will be perfect.

04





FINAL RESULT

Now you have joined the first three exhaust manifolds for the right bank to the respective fitting. Keep the assembled parts to one side, ready to be used in a following stage.

In the next stage

The last three exhaust manifolds for the right bank and their fitting.



LAST EXHAUST MANIFOLDS

THESE ARE THE LAST THREE EXHAUST MANIFOLDS WITH THEIR FITTING FOR THE RIGHT BANK, WHICH ARE ASSEMBLED IN THE SAME MANNER AS THE LEFT EXHAUST.



LIST OF PARTS

- 1 Manifold R6
- 2 Manifold R4
- 3 Manifold R5
- 4 Fitting part 2
- 5 Fitting part 1

SCREWS

Four type J screws



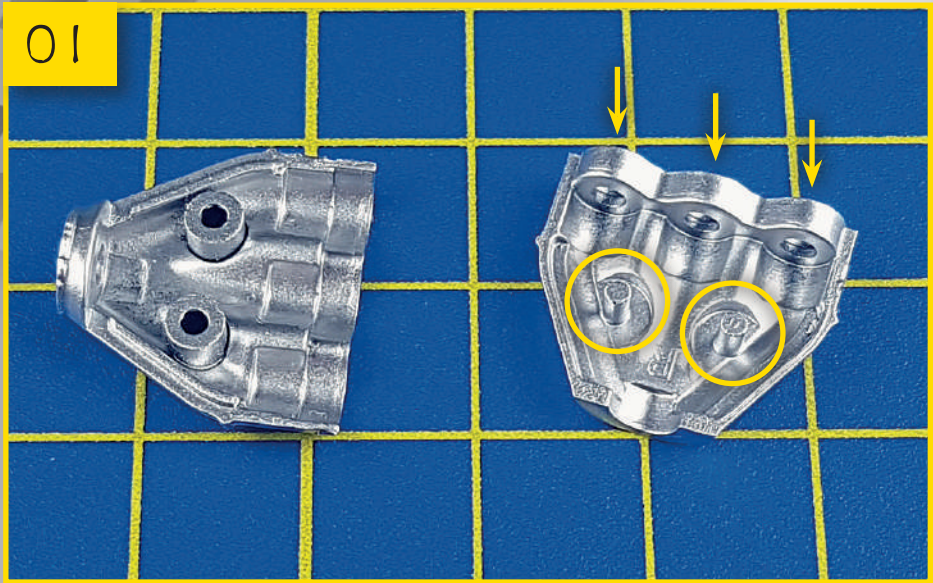

86-01
 Take the two parts of the fitting. As you can see, one of the two parts has two fixing pins and three holes for the fittings. Put the other part to one side, to be used later.

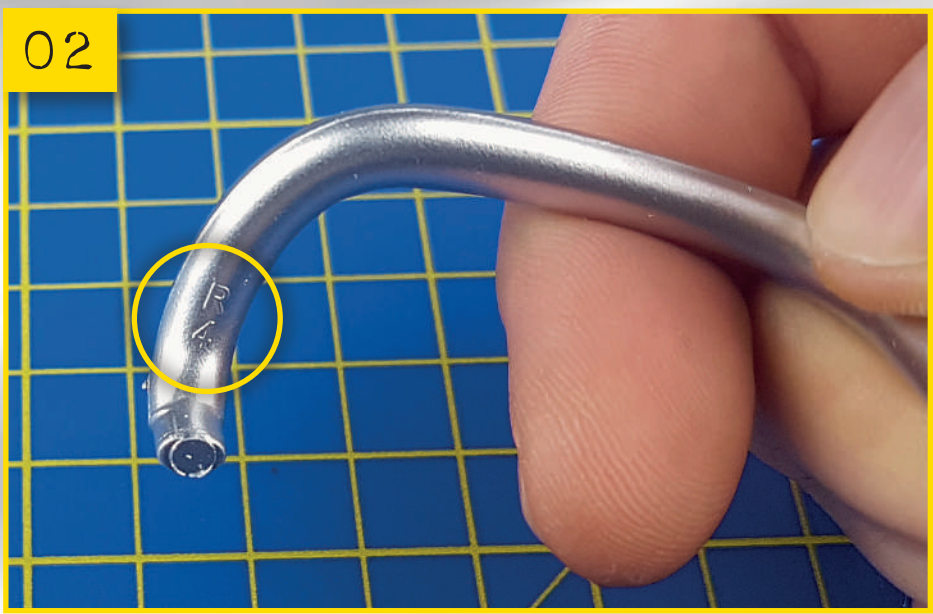

86-02
 Similar to the previous manifolds, these are printed with the letter R ("right") and a number to help identify them. The manifolds supplied with this stage are numbered 4, 5, and 6 and are for the right bank of the engine.

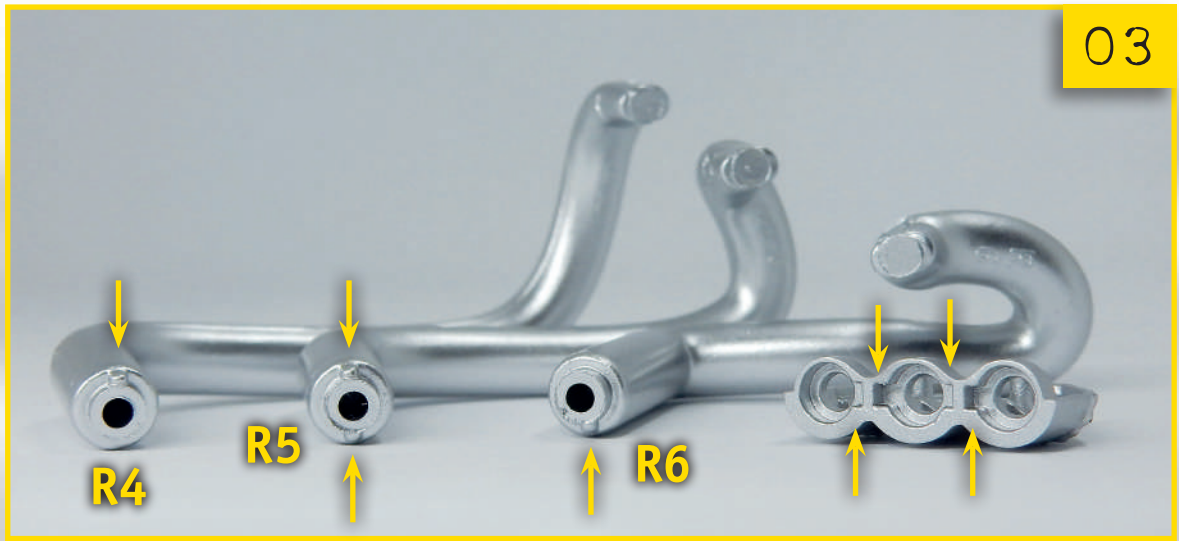

86-03
 The manifolds have one or two teeth to help find the exact position in the slots on the fitting.

04

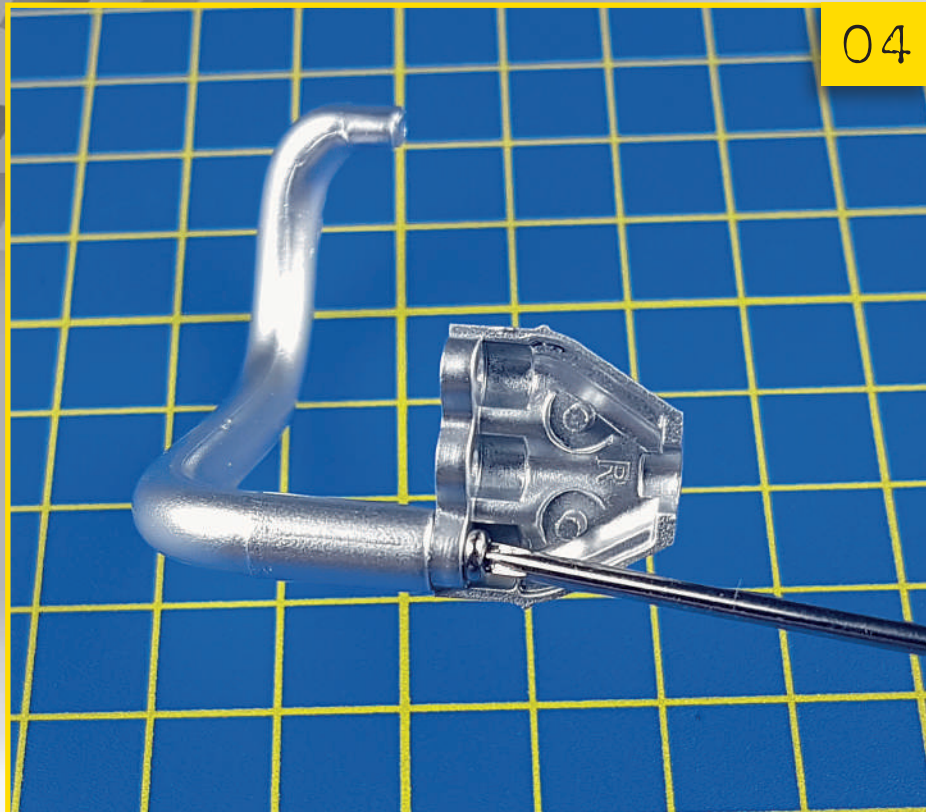

86-04 Take part 2 of the fitting and secure manifold 4 to it, using a type J screw. Important: to make sure the manifold is facing the right way, it is necessary to match the tooth in the slot at the front as you did before.

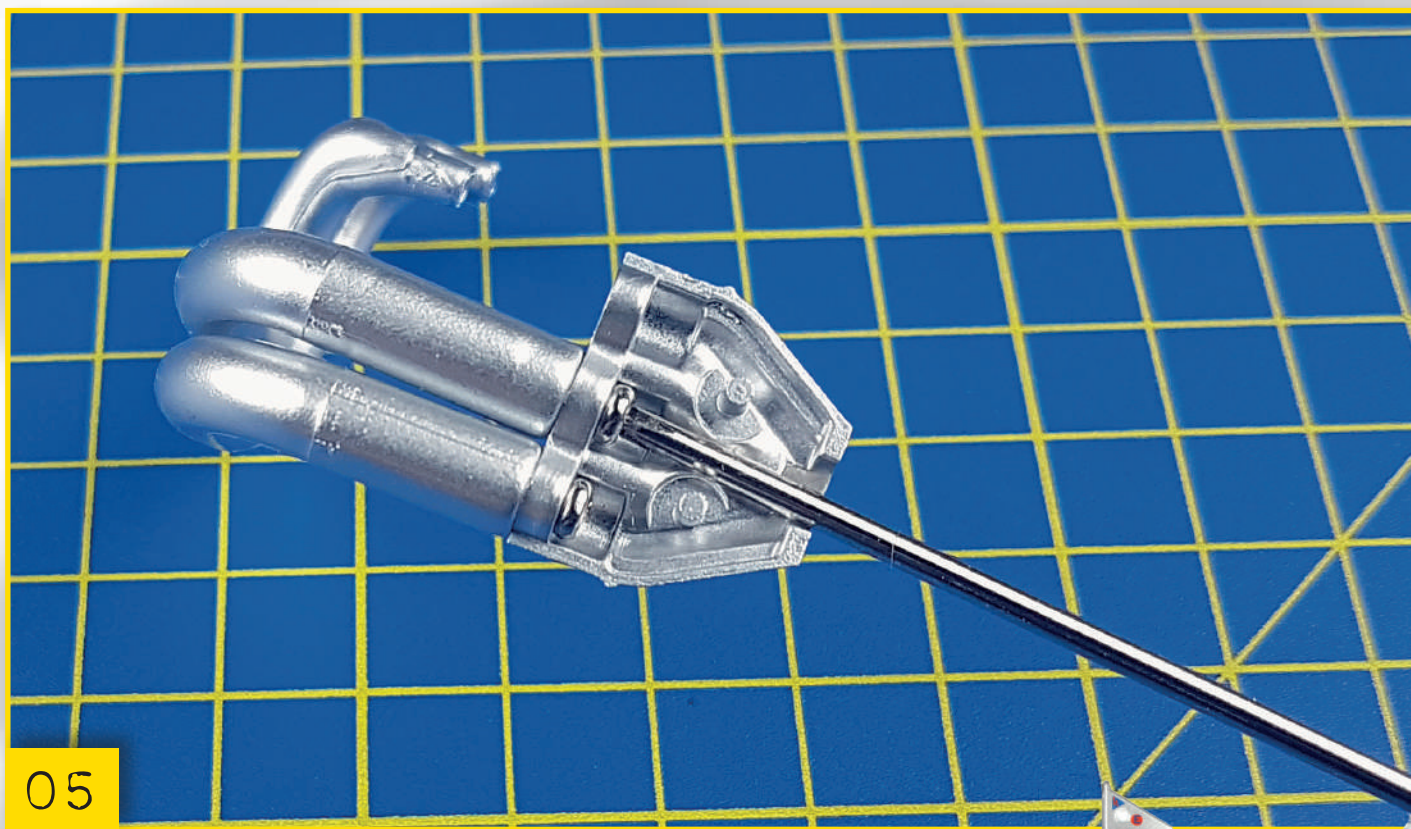

05

86-05

Proceed in the same way for manifold 5, placed in the central hole. Secure it with a type J screw.



06

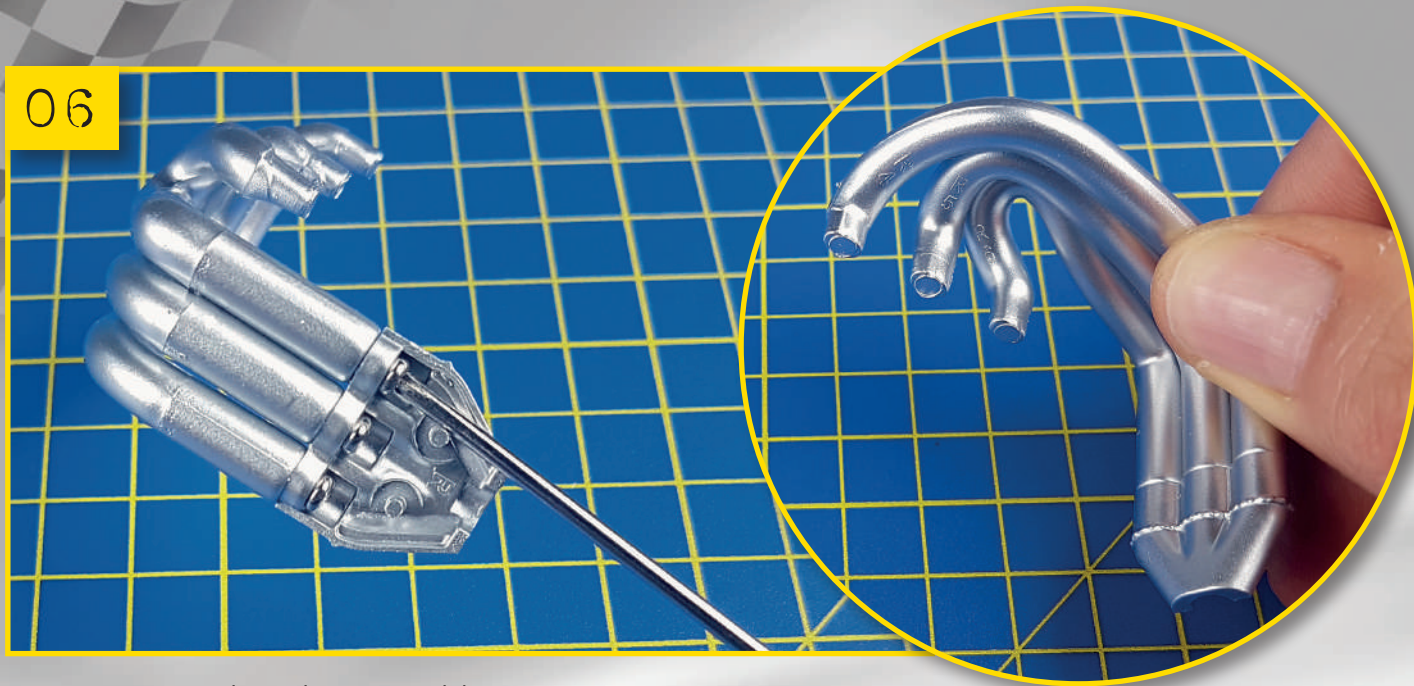

86-06 To complete the assembly, secure the manifold 6 to part 2 of the fitting, using a type J screw. Once assembled, the parts will be in the order R6, R5, and R4, starting from the inside.

FINAL RESULT

This is how the newly assembled parts will look.



In the next stage

Four exhaust pipes and springs to fasten to the relevant supports.



EXHAUST PIPES

WITH THE PARTS INCLUDED IN THIS STAGE, YOU CAN COMPLETE THE EXHAUST SYSTEM OF YOUR 1:8 SCALE FERRARI 312 T4.

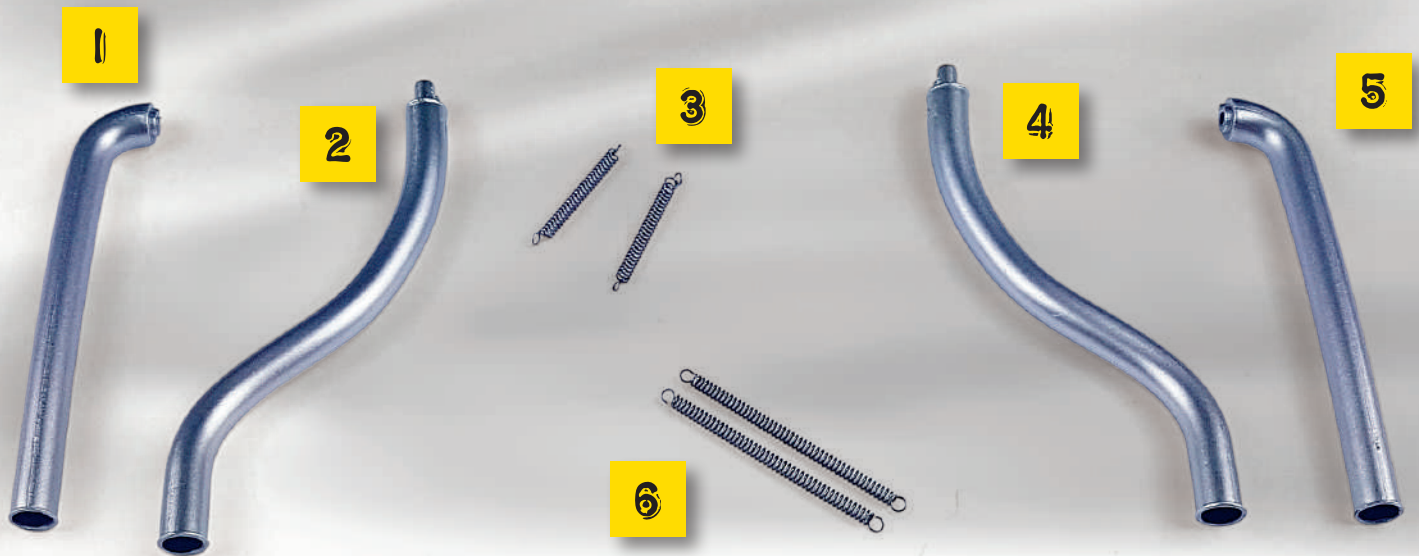

3 type J screws



LIST OF PARTS

- 1 Left exhaust pipe A
- 2 Left exhaust pipe B
- 3 Short lock system springs
- 4 Right exhaust pipe B
- 5 Right exhaust pipe A
- 6 Long lock system springs

SCREWS

Three type J screws



01

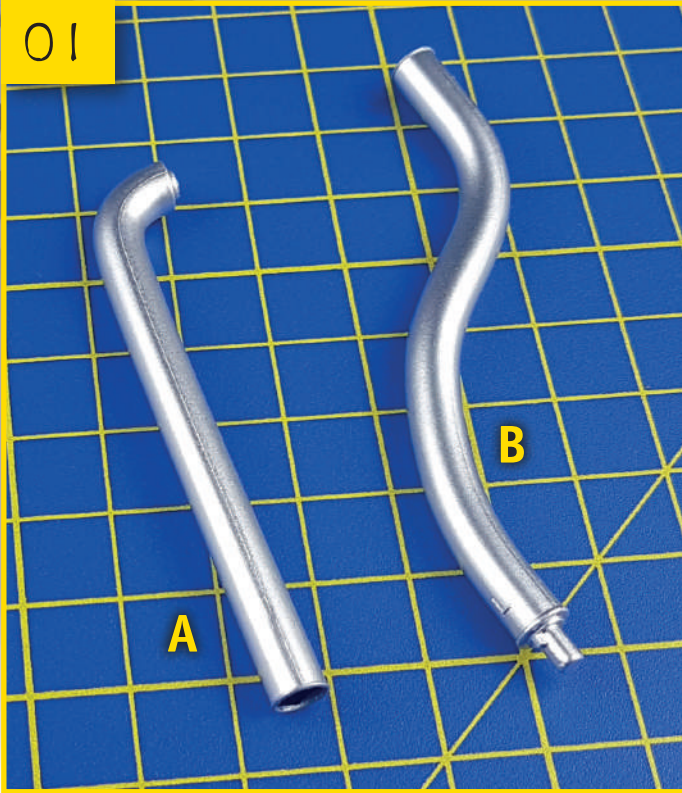

87-01

The two B pipes have printed letters on the part (as usual, "L" stands for "left", while "R" stands for the "right" side). To identify the two A pipes, check the list of parts above (page 17).

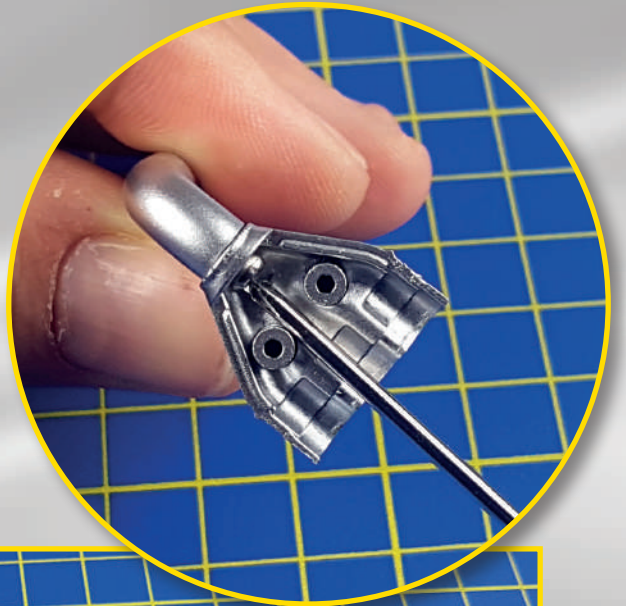

87-02 Take part 2 of the right fitting (supplied in stage 86), the right exhaust pipe A and a type J screw included with this stage. Secure the two parts with the screw. Repeat the same steps for the left side, using part 1 of the left fitting (stage 84), the left exhaust pipe A and a type J screw included with this stage.

02

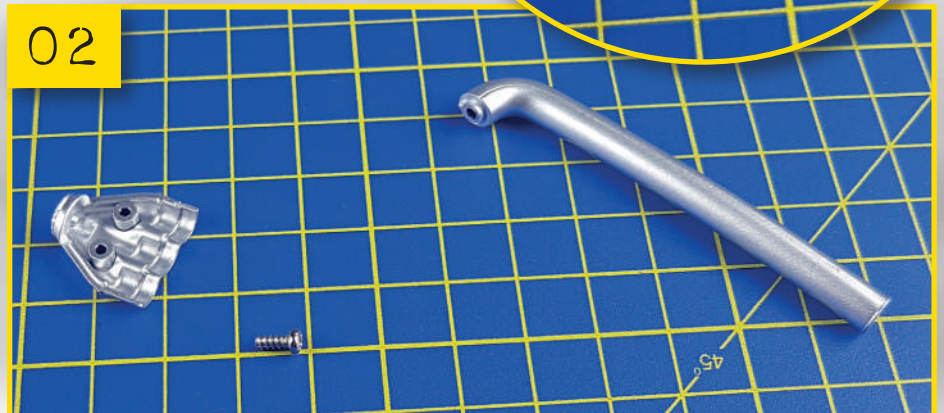

03

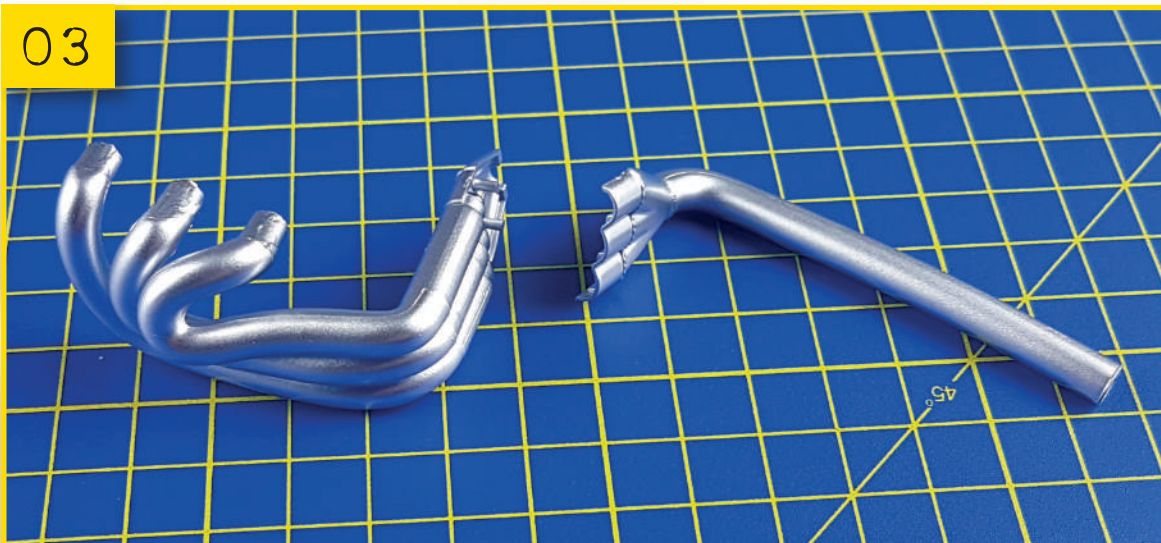

87-03

Take right exhaust manifold assembly (stage 86), and the right exhaust pipe A assembly from the previous step.

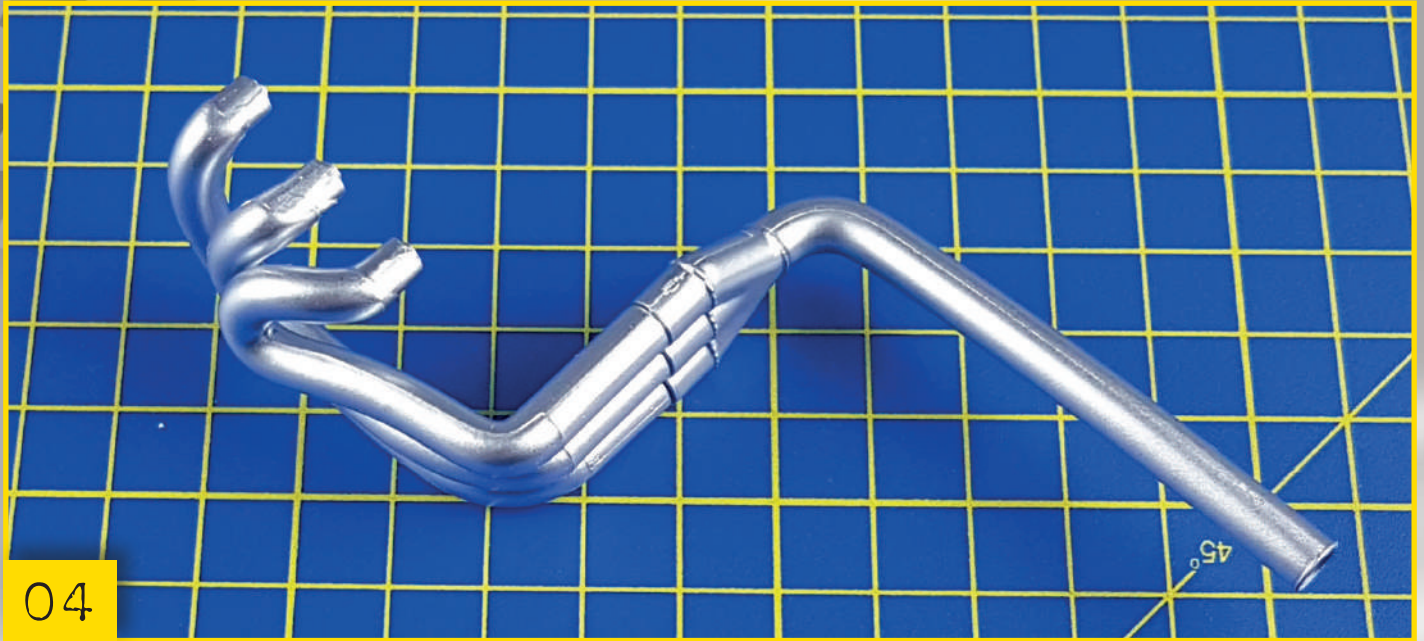

87-04 Press the fitting's two halves together to form the first right exhaust pipe. Repeat this to assemble the exhaust manifolds for the left bank of the engine (assembled with stage 84) and the left exhaust pipe A, pressing the two fitting parts together.



87-05 Take the group of exhaust manifolds from stage 85 for the right bank of the engine, together with the right exhaust pipe B.



06



87-06

Press the two parts together, correctly inserting the reference tooth on the exhaust pipe B into its seating. You have assembled the second right exhaust pipe.

To complete this stage, all you have to do is repeat the last two steps, joining the exhaust manifold group for the left bank of the engine (assembled in stage 83) and the left exhaust pipe B included with this stage.

FINAL RESULT

This is how the exhaust pipes should look. The position shown is not the one they will have after being installed on the vehicle; this picture serves to check the assembly of the parts is correct.



In the next stage

First parts of the left side bodywork.



COCKPIT LEFT BELLY

THIS STAGE INCLUDES THE PARTS NEEDED TO ASSEMBLE THE TOP PART OF THE COCKPIT LEFT BELLY.



3 type J screws



LIST OF PARTS

- 1 Cockpit left belly
- 2 Air intake detail

SCREWS

Three type J screws



01

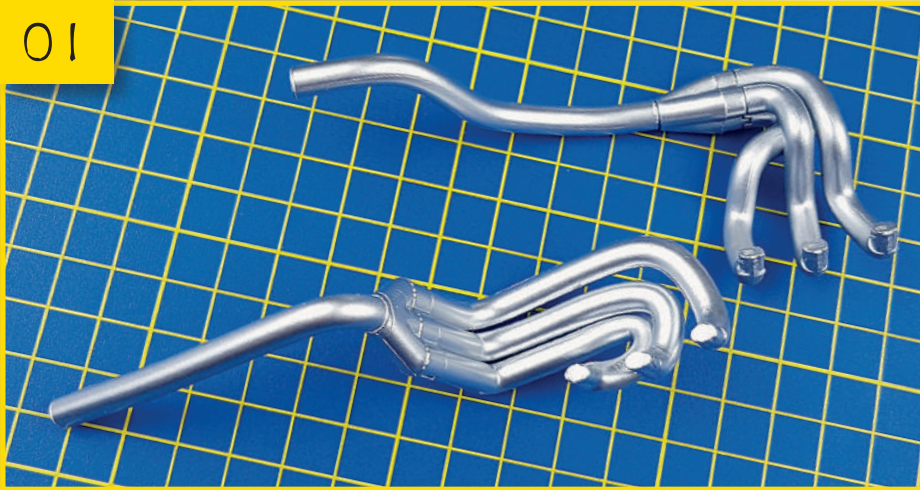

88-01 Take the assembly of the two exhaust pipes from the left bank, as completed in the previous stage. To make installing this easier, temporarily remove the rear wing: slide it out from its support on the rear suspension bar.

02

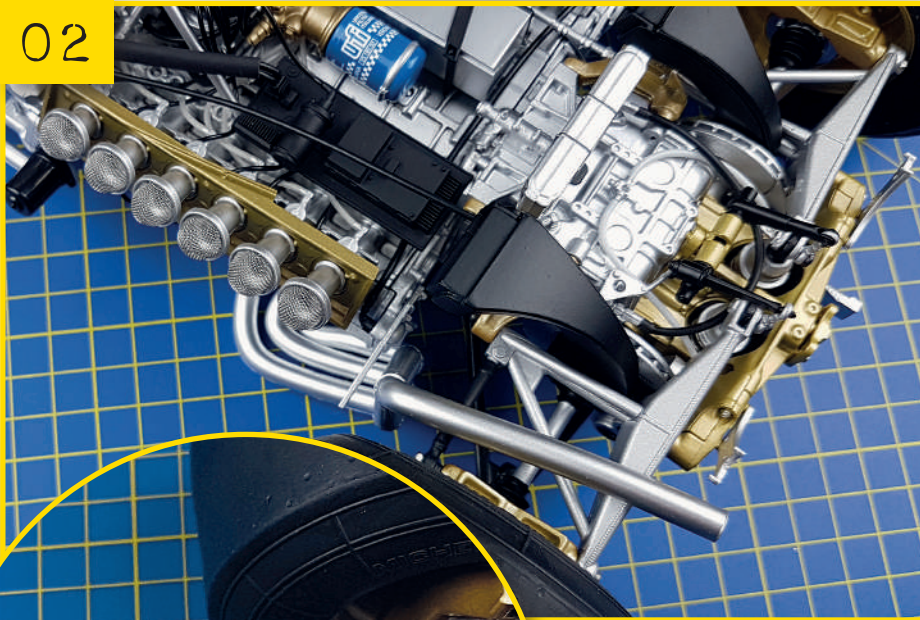

88-02 Gently lift the model and slide in the exhaust pipe with the flat fitting, from underneath and upwards in front of the plate supporting the skirts. Rest the pipe on the left wishbone. After turning the model over, press the three manifolds into the three holes, starting with the one closest to the rear suspension, as shown in the inset photo.



88-03 Turn the model over again and rest the exhaust pipe on the support fitted in the steps for stage 82, and marked with a yellow arrow in the inset photo.

03

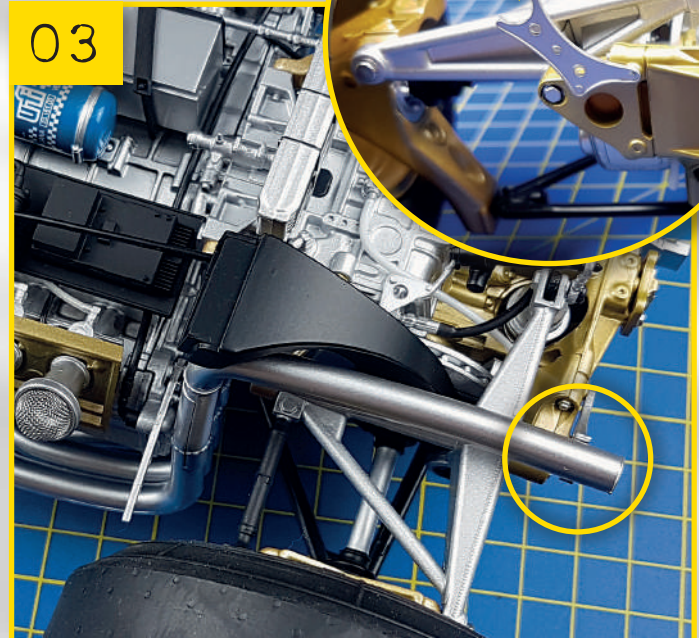

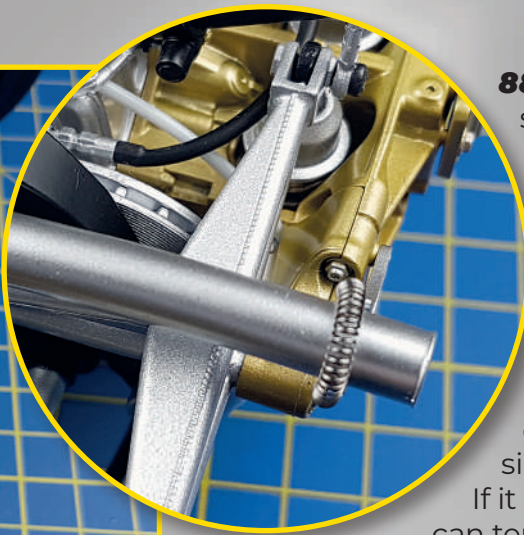
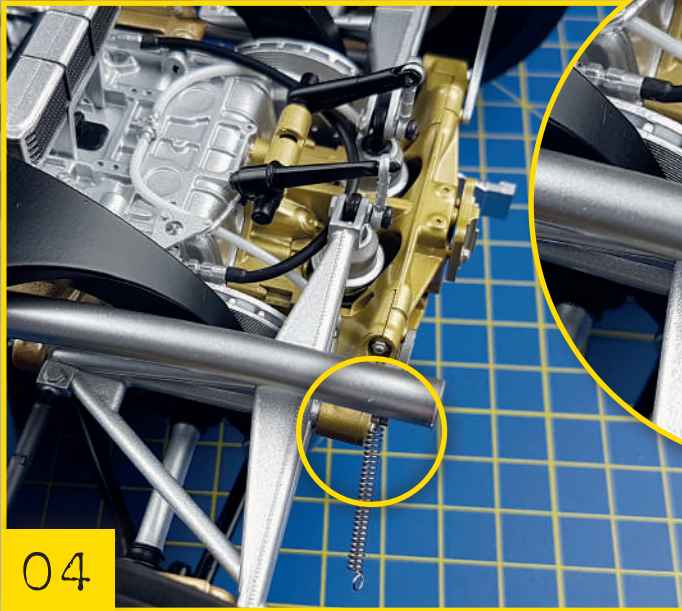

88-04 Take one of the short springs included with stage 87. Insert a spring eyelet over the bottom pin on the plate. Use long-nose tweezers, if necessary. Pass the spring over the exhaust pipe and insert the second eyelet over the pin on the other side of the exhaust pipe.

If it proves a little fiddly, you can temporarily remove the plate, fit the spring on both pegs and then, after sliding in the exhaust pipe, refit the plate in its housing.

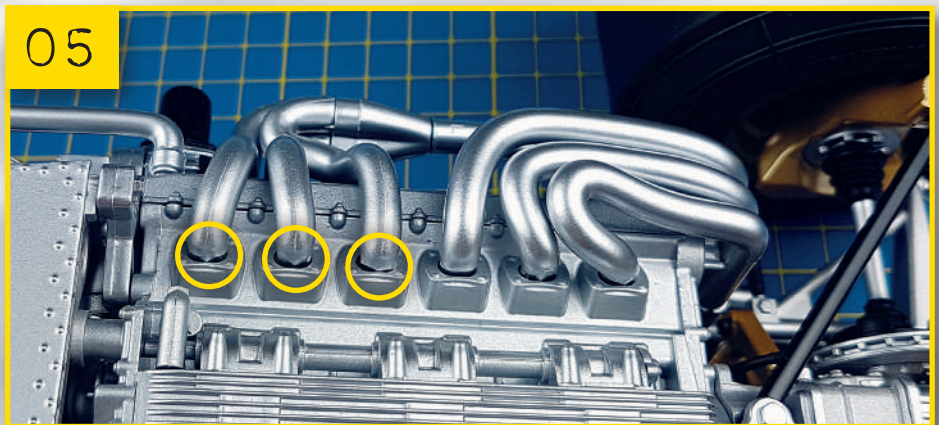

88-05

Turn the model over and insert the three manifolds of the second exhaust pipe in the remaining three holes of the left bank, as shown.

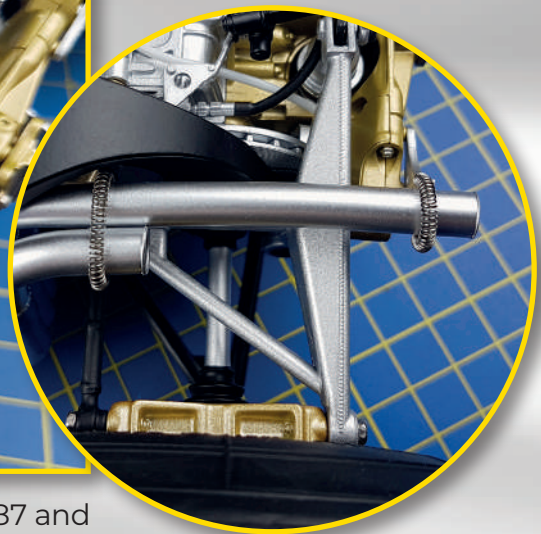
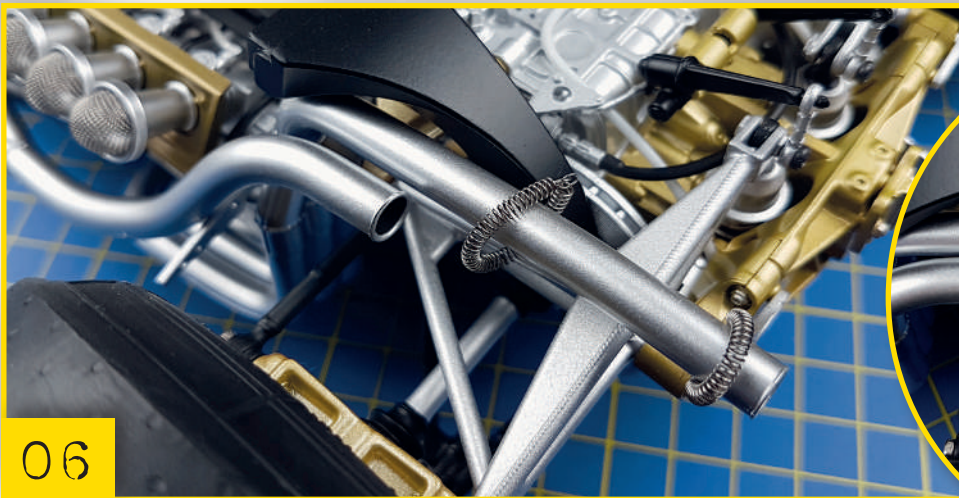

88-06 Take one of the two long springs supplied with stage 87 and place it on the first exhaust pipe, joining the two eyelets together. Extend the spring gently to press it over the second exhaust pipe and then position it at about 6 mm from the end of the short exhaust. Turn the spring so that the eyelets are not visible.

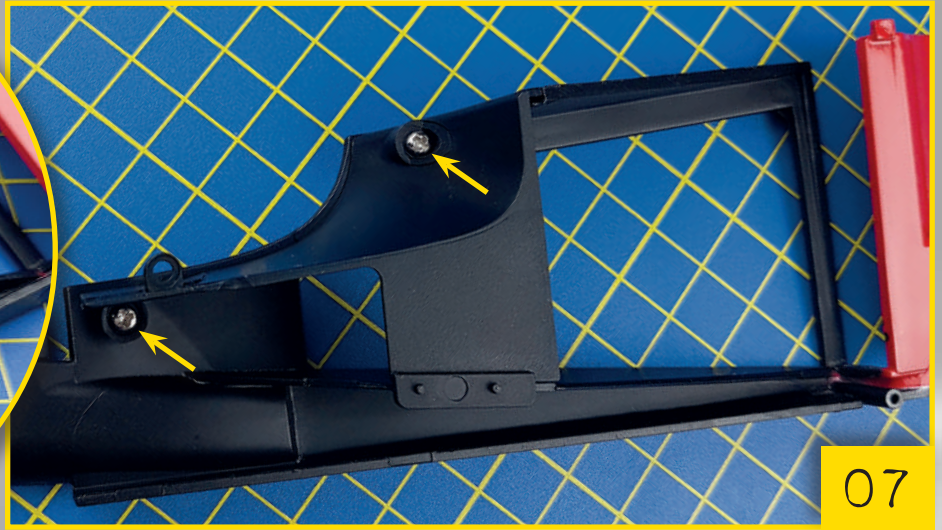
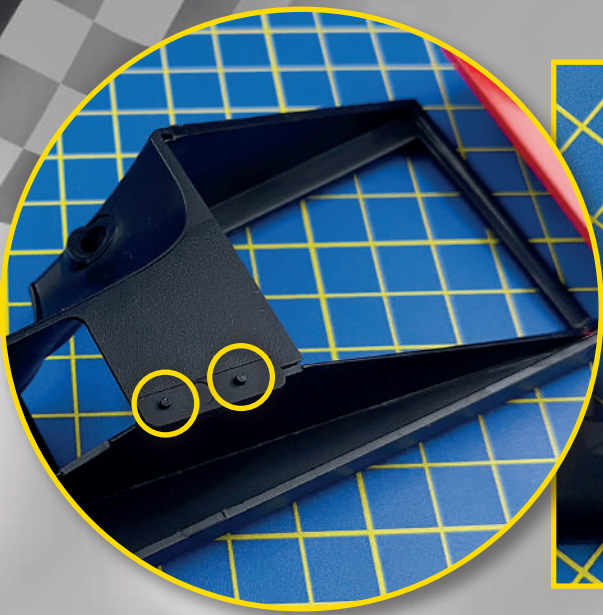

88-07 Take the parts supplied with this stage and join them together, coupling the pins with the relevant holes (inset, circled) and making sure the screw holes are aligned (above, arrows). Then secure the two parts with two type J screws.

FINAL RESULT

Your model should now look like this.

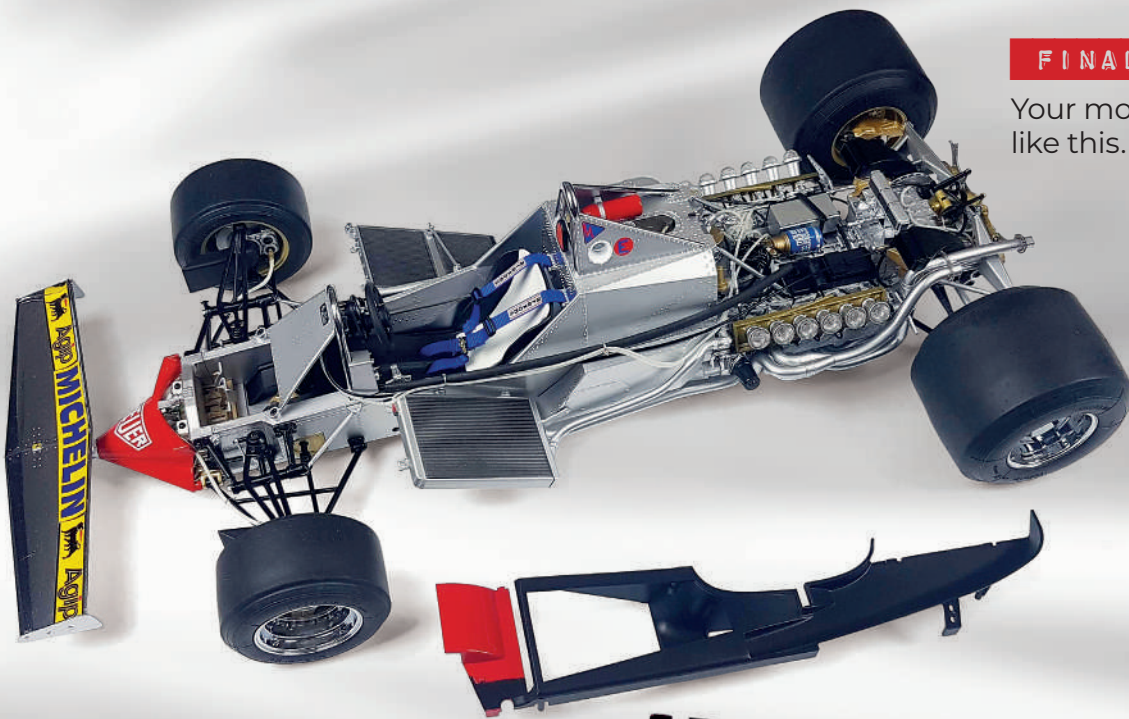

In the next stage

Cockpit right belly parts.



COCKPIT RIGHT BELLY

THIS STAGE INCLUDES THE PARTS YOU WILL NEED TO ASSEMBLE THE UPPER PART OF THE RIGHT SIDE COCKPIT BELLY FOR YOUR FERRARI 312 T4. MODEL

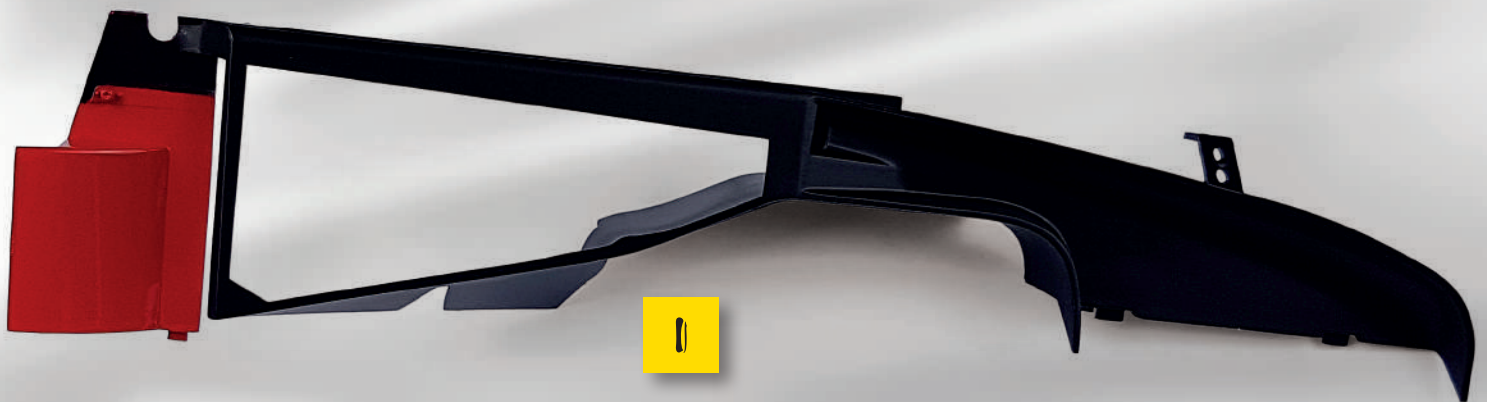

1



3 type J screws



2

LIST OF PARTS

- 1 Cockpit right belly
- 2 Air intake detail

SCREWS

Three type J screws



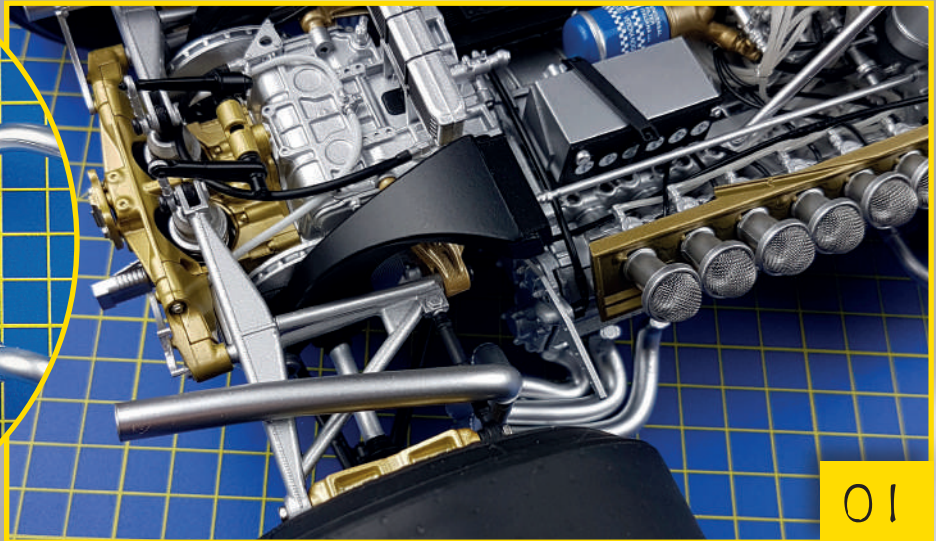
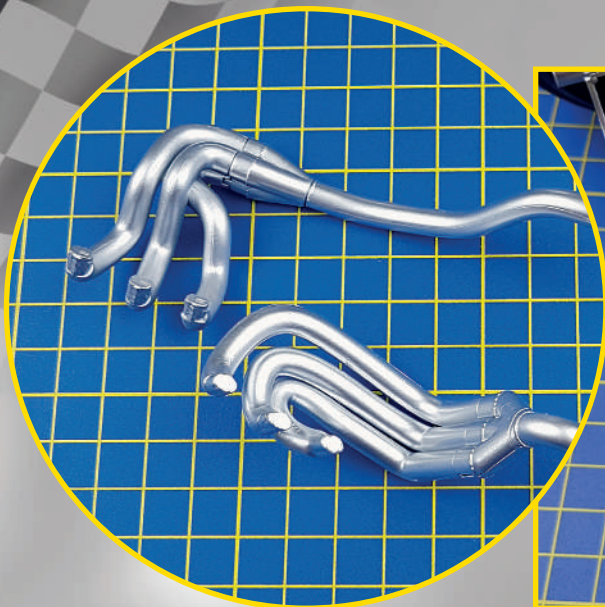

89-01 Take the assembly of the two right bank exhaust pipes assembled with stage 87. Lift the model and slide in the exhaust pipe with the flat fitting, from underneath and upwards in front of the plate supporting the skirts. Rest the pipe on the right wishbone.

89-02

After turning the model over, press the three manifolds into the three holes as shown, starting with the one closest to the rear suspension. Turn the model back up and rest the exhaust pipe on the support fitted with stage 82, and marked with a yellow arrow in the inset photo.

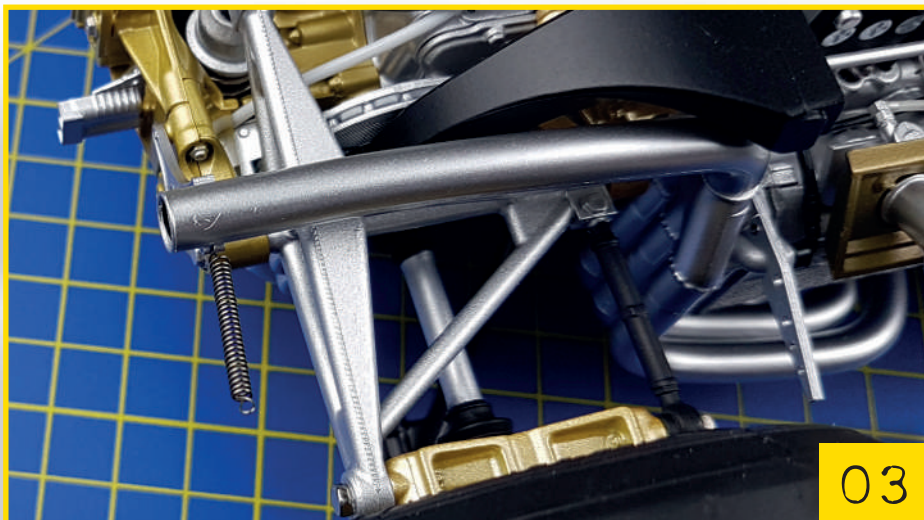
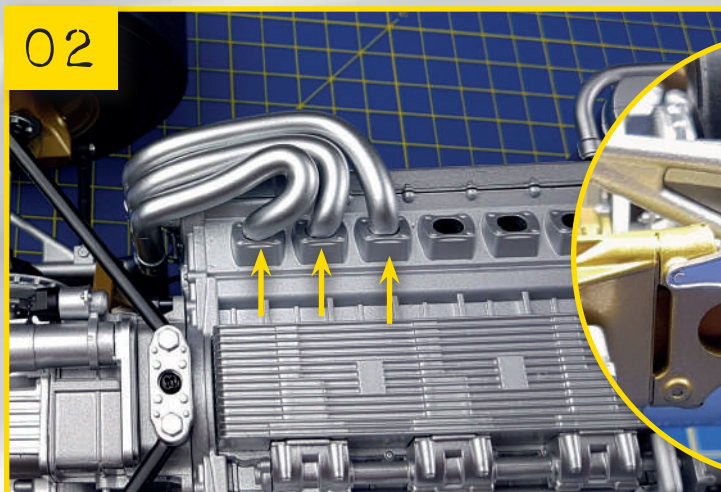

89-03 Take one of the two short springs supplied with stage 87 and insert a spring eyelet into the bottom pin on the plate. Use tweezers to do this, if necessary.

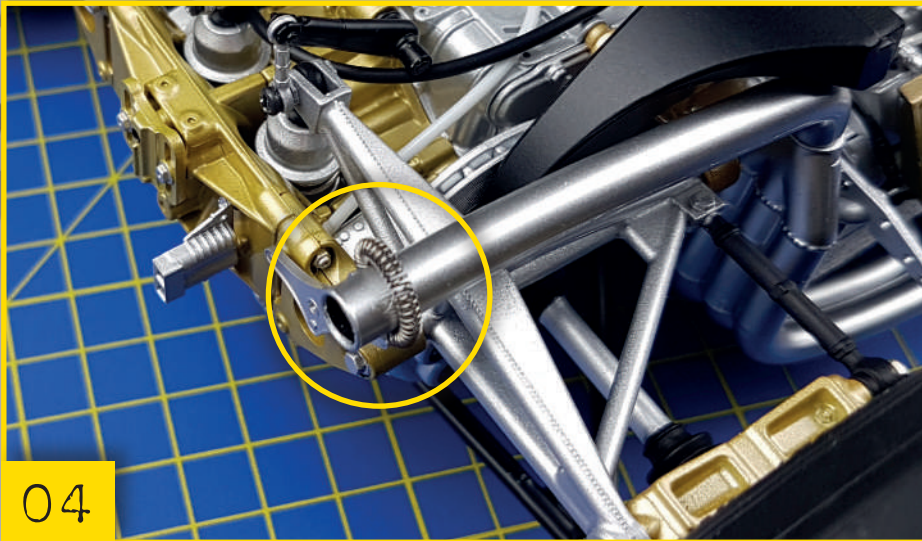

04

89-04

Pass the spring over the exhaust pipe and insert the second eyelet over the pin on the other side of the exhaust pipe. You can temporarily remove the plate then fit the spring on both pegs. After sliding in the exhaust pipe, refit the plate in its housing.

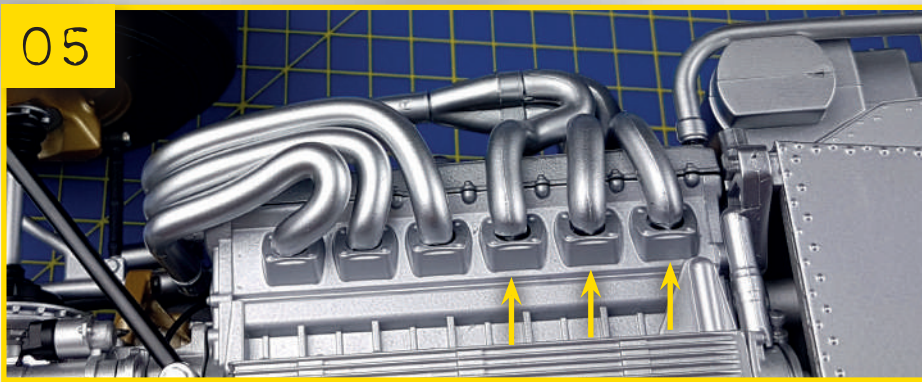

05

89-05

Turn the model over and insert the three manifolds of the second exhaust pipe in the remaining three holes of the right-hand bank.

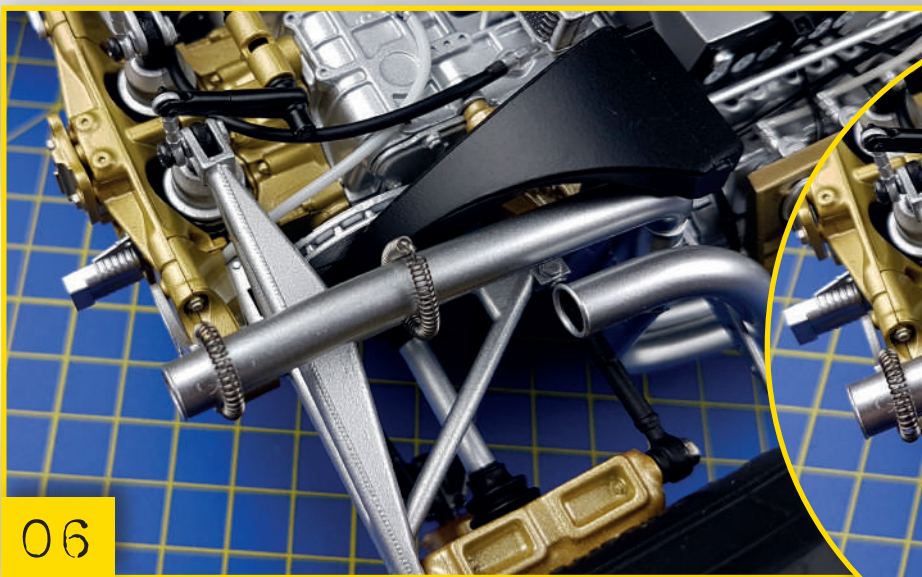

06

89-06 Take one of the two long springs supplied with stage 87 and place it on the first exhaust pipe, joining the two eyelets together. Gently stretch the spring over the second exhaust pipe and then position it at about 6 mm from the end of the short exhaust, turning it so that the eyelets do not show.





89-07

Now you can place the rear wing back in its housing.

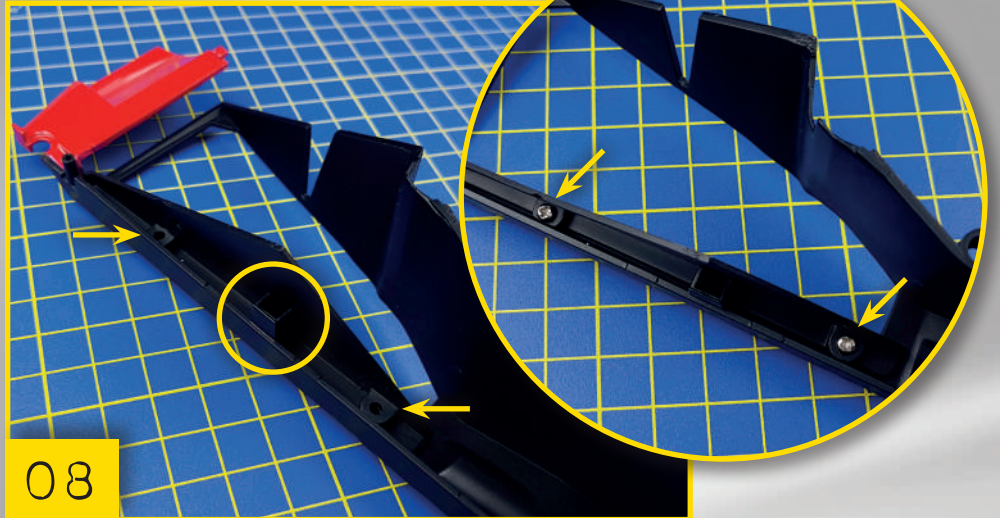

89-08

Take the parts provided in this stage and join them together so that the C-shaped upright matches with the rectangular slot in the bulkhead (circled in the photo) and fixing points (arrows in the photo). Then secure the two parts using two type J screws (arrows in the inset photo).

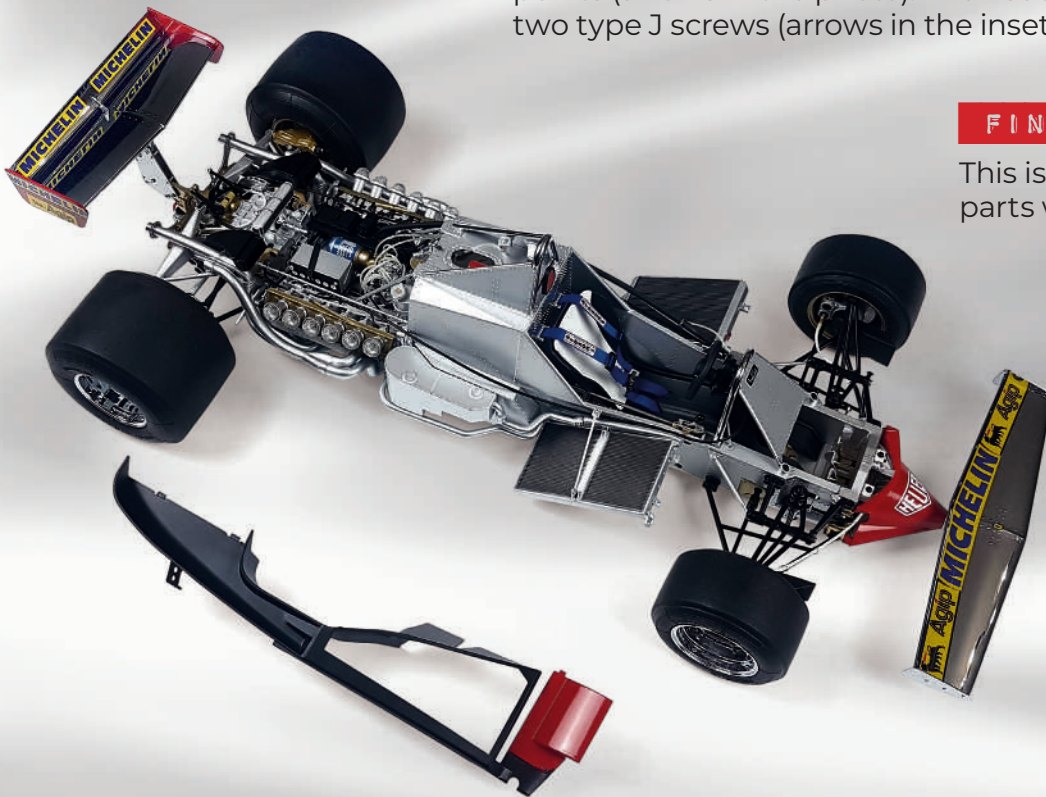

FINAL RESULT

This is how the newly installed parts will look.

In the next stage

The right side and the support elements for the sides.



RIGHT BOTTOM BELLY

THIS STAGE CONTAINS THE PARTS TO COMPLETE AND INSTALL THE RIGHT SIDE BELLY: THE LOWER SECTION, TUBULAR PROFILES TO FASTEN THE BELLY, AND THE RELEVANT FASTENING SCREWS.



LIST OF PARTS

- 1 Right belly bottom detail
- 2 Inner closing profile
- 3 Tubular belly fastening profiles x2

SCREWS

Three type H screws
Two type J screws



HOW TO JOIN THE TWO PARTS OF THE RIGHT BELLY.

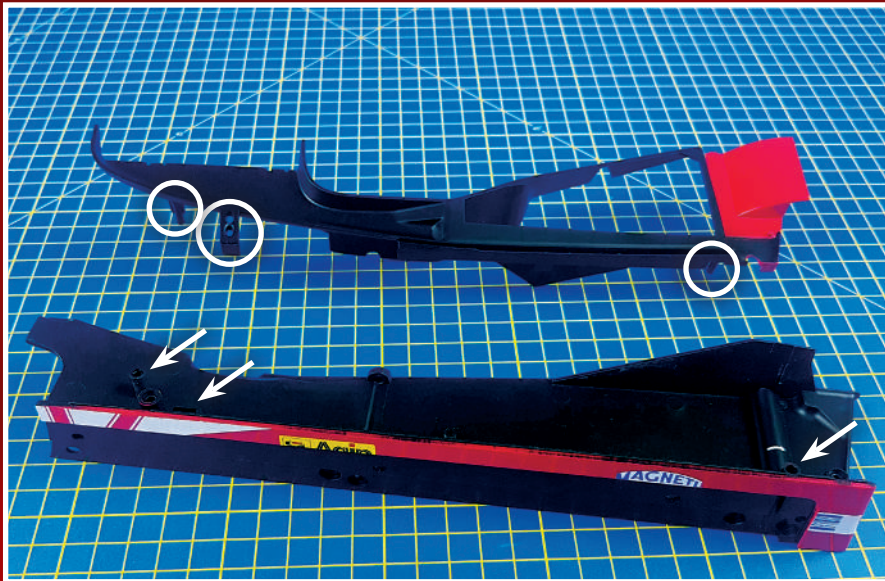

This page shows how the two upper and lower parts of the right belly are assembled together. The photos clarify points where the two elements join.

We strongly recommend you do not try to fit them together before assembling them on the model itself, since trying to separate them again could damage them.

Front (photo A): the two parts of the side belly are perfectly matched; the inner and rounded protruding section of the bottom belly sits in the relevant recess of the top one.

Back (photo B): the parts are joined by a pin and bracket on the top belly, which need to be inserted all the way into the special seats on the bottom part.

Lastly, **inside** (photo C): there is a bored post which is used to insert a type J screw, for stable joining of the two side belly parts.

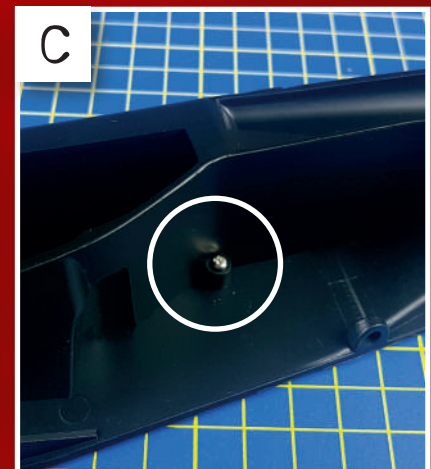
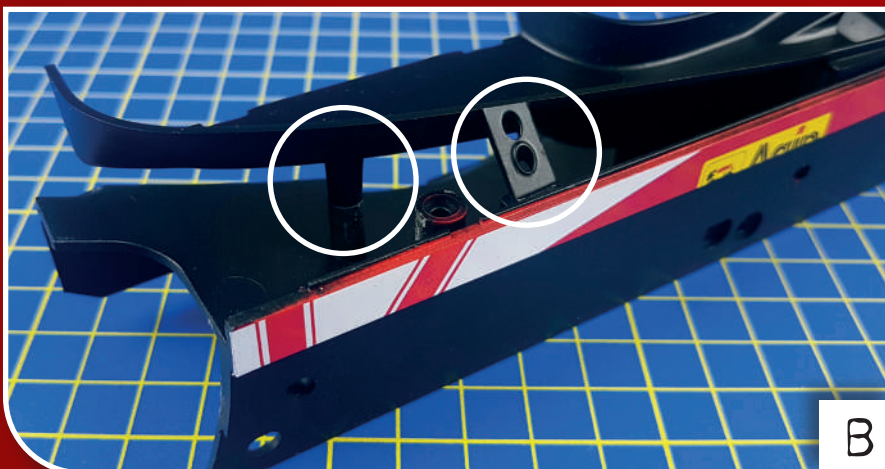
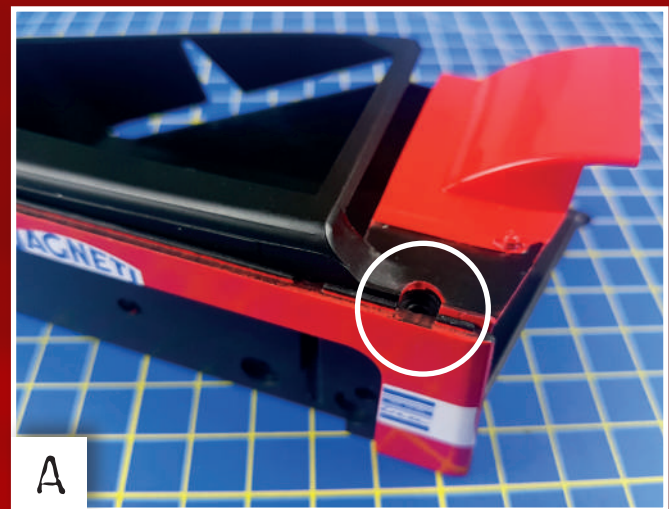

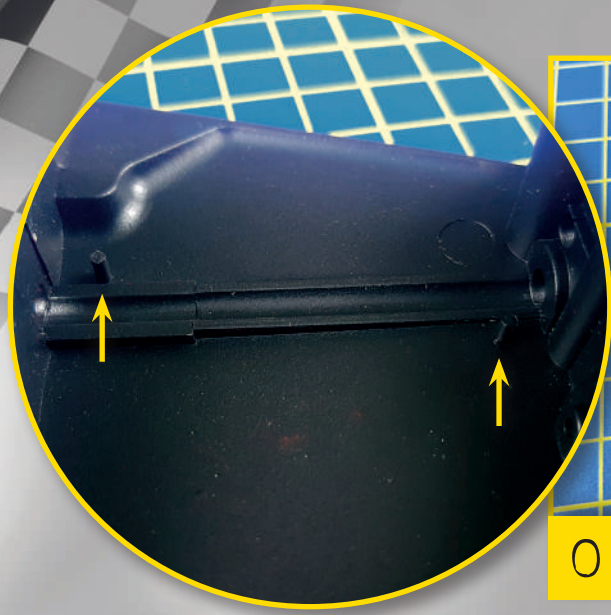

90-01
 Inside the lower part of the right belly are two pins (inset photo). These pins are used to secure the closing profile. Make sure the white arrow printed on the part in question is facing the right direction.

01

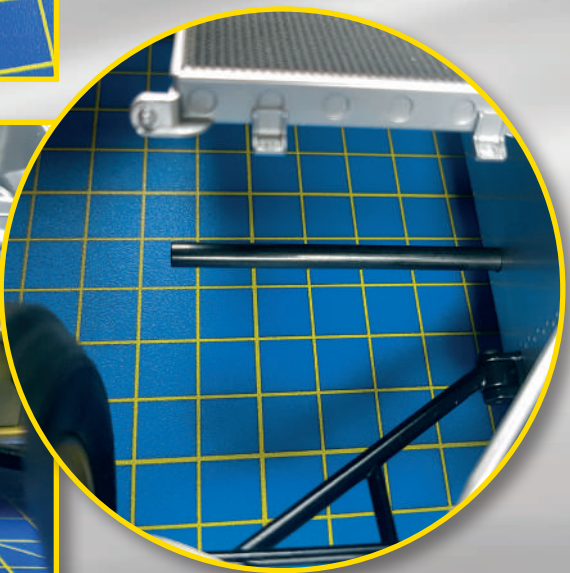

90-02 Insert a first support tube for the belly at the front. The tube will cross the whole model.

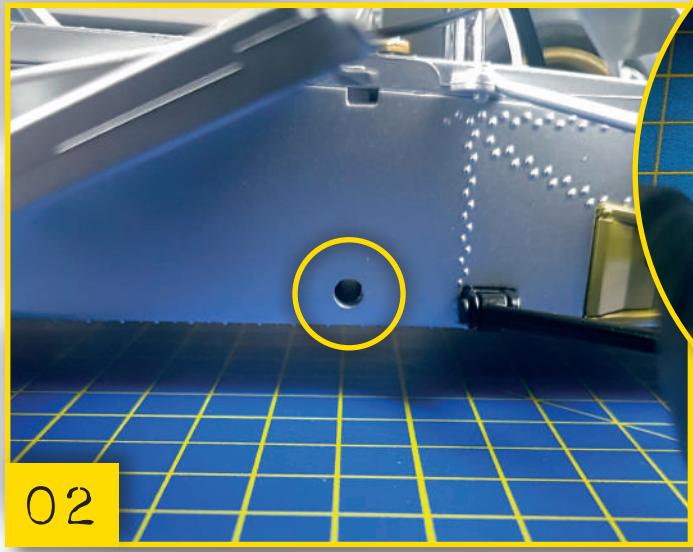

02

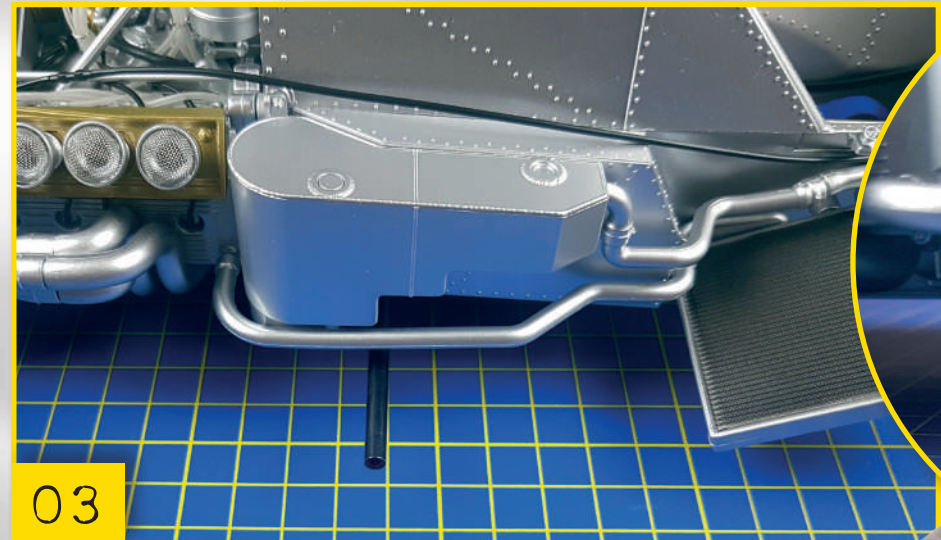

03

90-03 Insert a second support tube for the belly at the back. Make sure the two tubes are flush with the right side of the body.

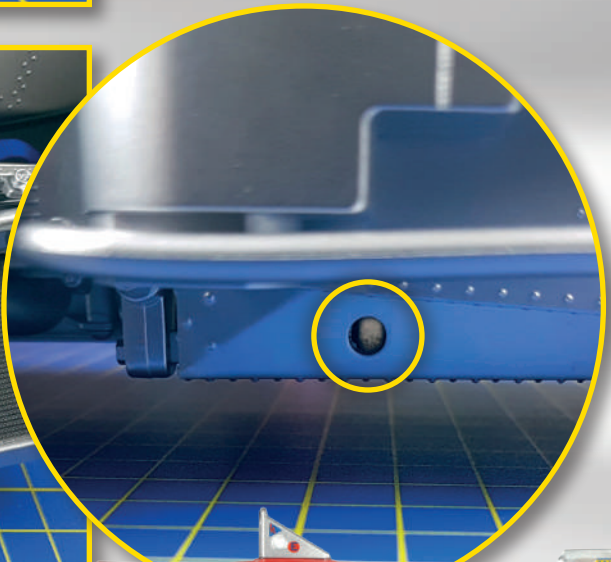

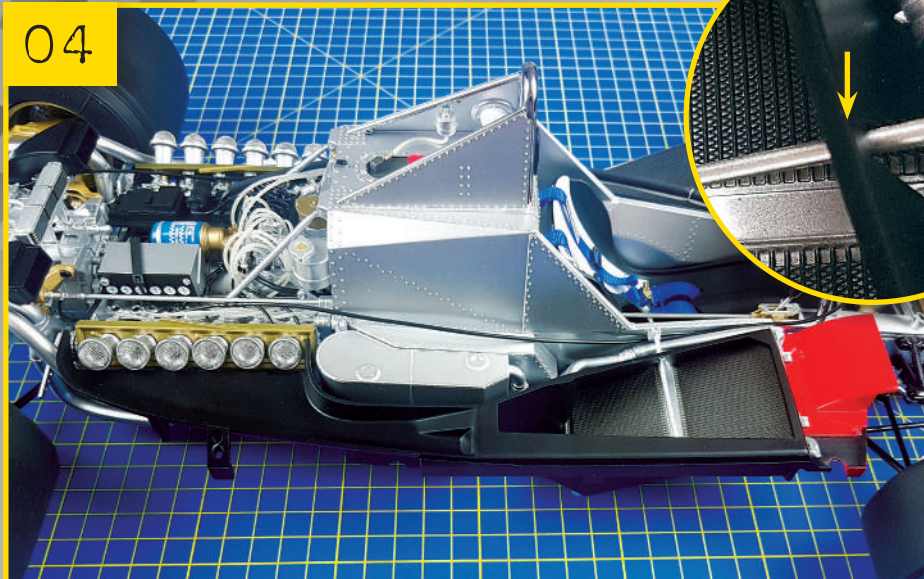

90-04 Now join the right upper belly to the model. Make sure that the red air intake is under the radiator. The tooth on the air intake must be inserted in the hole close to the radiator. A special slot on the inside of the upper belly will house the radiator tie-rod (see detail). In the back section, the upper belly profile must be positioned under the air funnel trumpet.

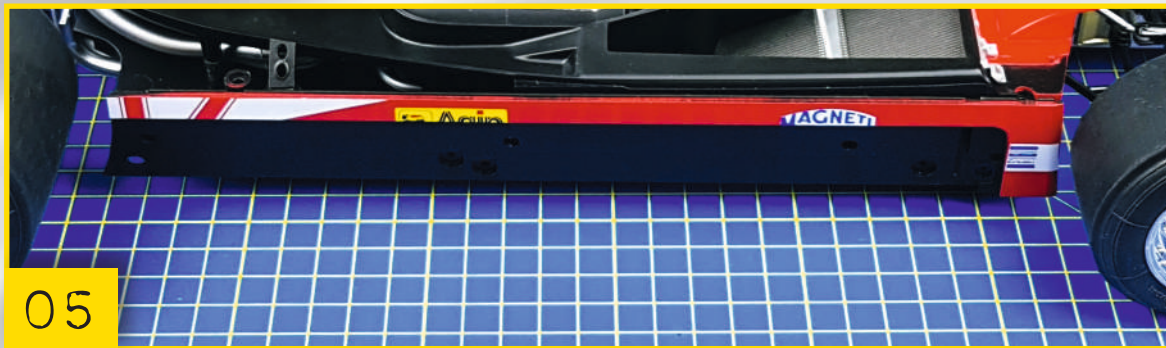

90-05 Bring the bottom part of the right belly to the model. Keep it slightly angled downwards so that the front part is positioned above the suspension wishbone. Then line up the joint elements of the two belly parts, as shown on page 30. Now insert and tighten the fastening type J screw.

CONTINUED

Given the complexity of the assembly process for the right belly, these steps will continue in the next stage. Carefully place your unfinished model to one side, together with any left-over parts.

In the next stage

Lower part of the left belly.



LEFT BOTTOM BELLY

USE THESE PARTS TO COMPLETE ASSEMBLY OF THE LEFT SIDE BELLY THEN INSTALL IT ONTO YOUR MODEL.



3 type H screws



2 type J screws



LIST OF PARTS

- 1 Left belly bottom detail
- 2 Inner rear closing profile

SCREWS

Three type H screws
Two type J screws



91-01 Continue with the assembly stage you began with stage 90: take a front tubular profile and push it until it emerges from the right belly. Use a Phillips screwdriver to secure a flanged type H screw at the threaded end of the profile.

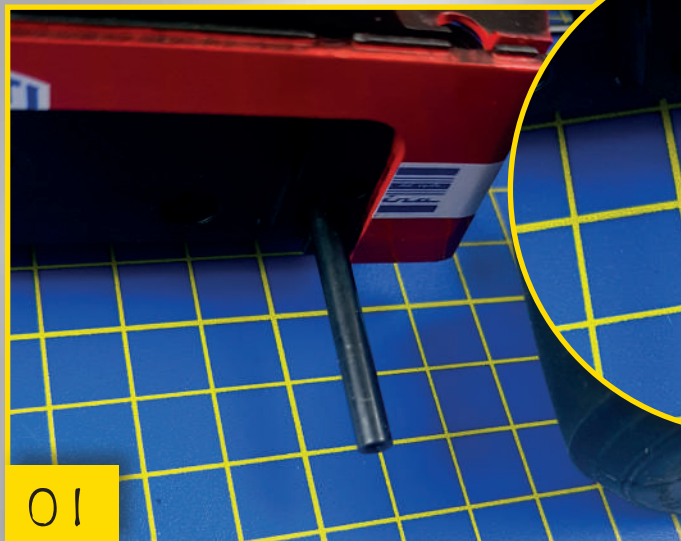

91-02 Push the front profile until it is up against the right-hand belly as shown.

91-03 Carry out the same steps for the rear profile, which must come out from the right belly. Insert a flanged type H screw and tighten, then push the rear profile until the screw is up against the right belly.

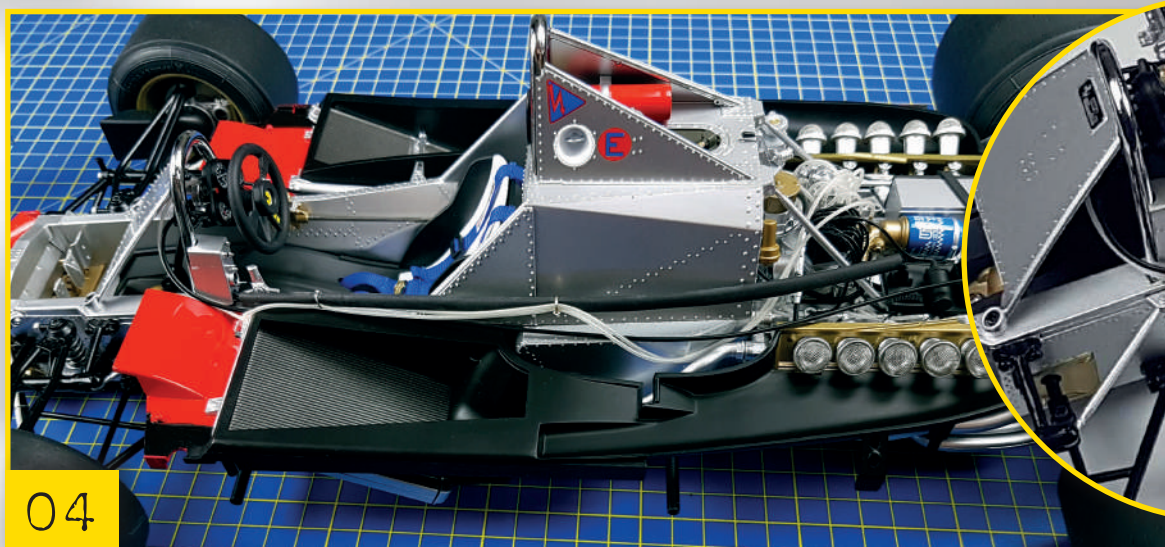

91-04 Now you can move on to the left side. Take the left upper part and first insert the red air intake under the radiator, then put the rectangular pin in the seating of the same shape on the monocoque (see the inset photo).

91-05

Install the closure profile inside the belly, so that it is facing as shown in the image. Match the pins and assembly holes together.

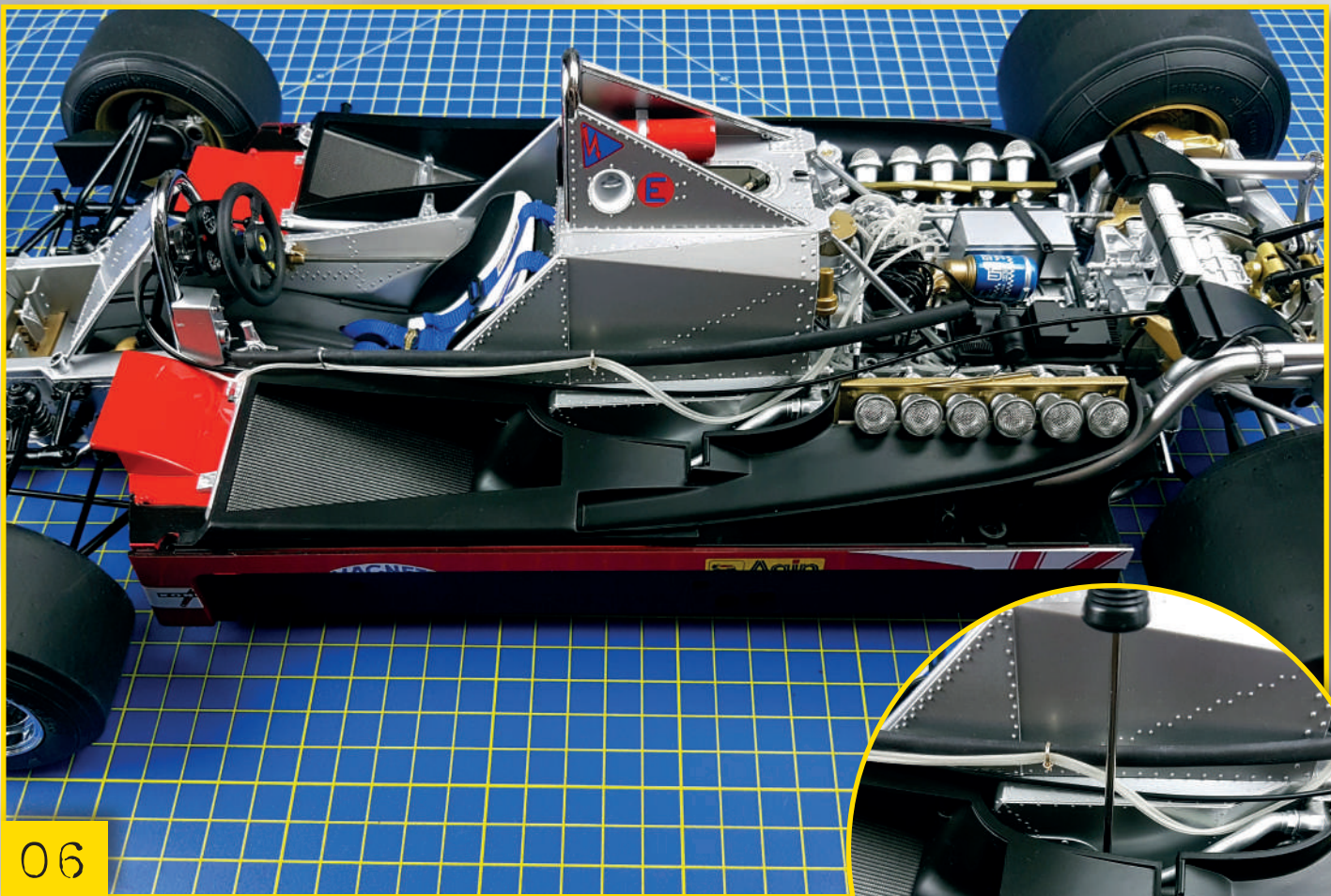
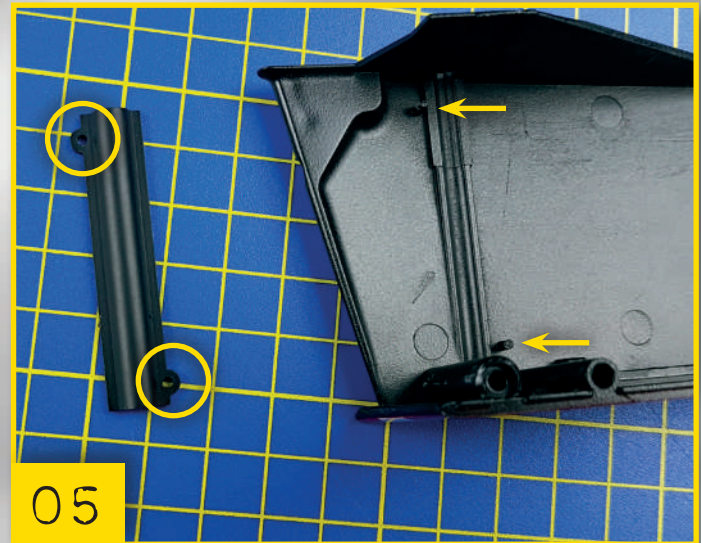

91-06 Push both tubular profiles towards the right belly until they are up against the monocoque. Take the lower belly and put it in place, keeping it at a slight downwards angle to allow the correct position above the suspension wishbone. Then match up the various fastening parts; they are similar to the ones shown on page 30 (stage 90) for the right belly. Finally, fasten a type J screw in the inner hole.

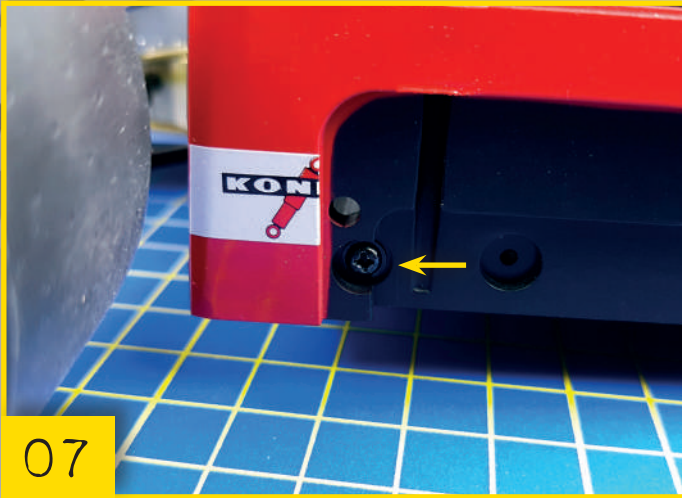

07

91-07 Push the front tubular profile until it comes out of the left belly, then fasten it with a flanged type H screw.



08

91-08 Carry out the same steps on the rear profile.

FINAL RESULT

This is what your model will look like at the end of this session.

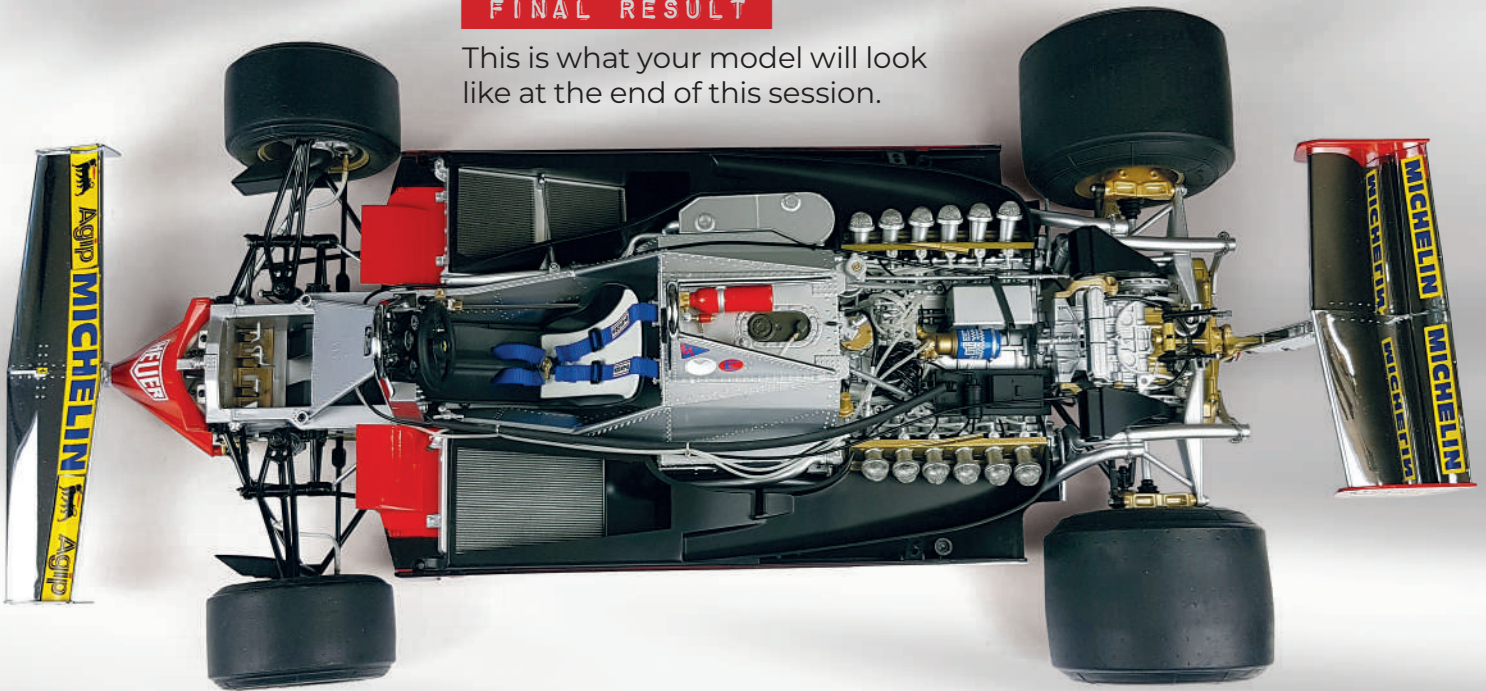

In the next stage

The parts of the bottom left skirt and outer bulkhead.



LEFT SKIRT AND BULKHEAD

THIS STAGE PROVIDES THE SKIRT AND THE BULKHEAD WITH THE TECHNICAL PARTNER DECALS THAT WILL BE USED TO COMPLETE AND CLOSE THE RIGHT BELLY.

1



2



3 type P screws



LIST OF PARTS

- 1 Left bulkhead
- 2 Left skirt

SCREWS

Three type P screws



FASTENING POINTS FOR THE SKIRT AND RIGHT BELLY BULKHEAD

The images show the points for joining and fixing the skirt (A, B, C) and the bulkhead (D, E, F, G) to the left belly.

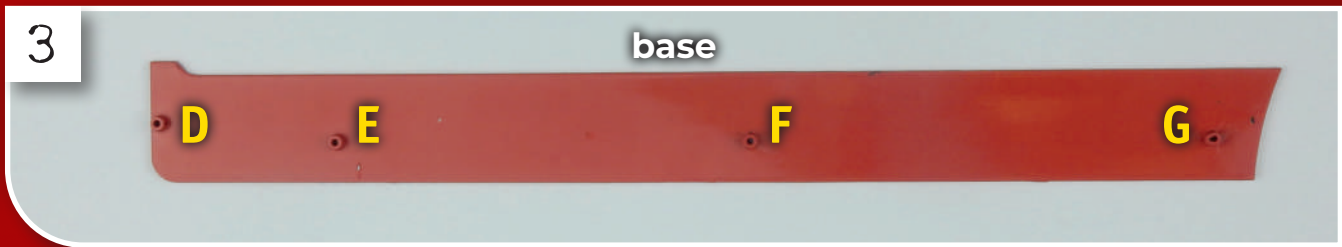
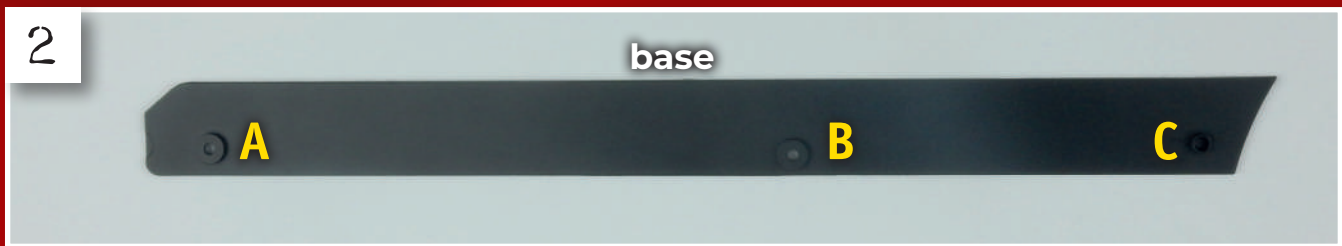

92-01 Place the model and the left skirt on your work surface. The arrows highlight the holes (A, B) where the fastening screws will be inserted.

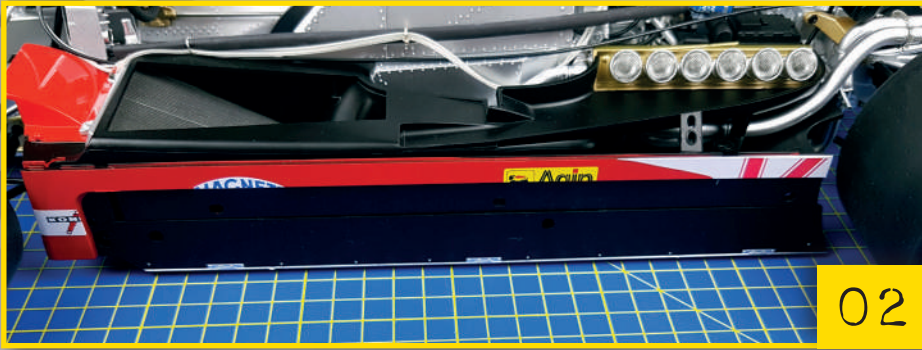

92-02

Position the skirt so that the fastening holes match with the screw seats.



92-03 Insert and tighten a type P screw in the first hole (A) in the front.



92-04 Insert and tighten a type P screw into the second hole (B) in the central part of the right belly.

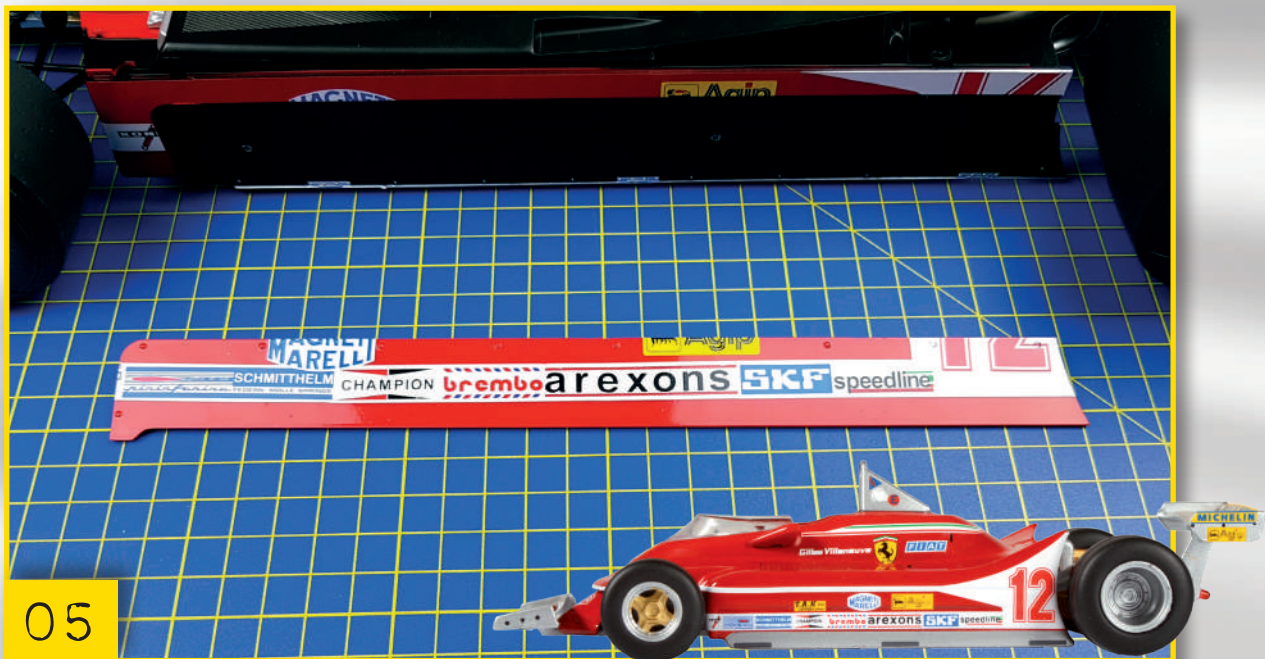

92-05

Now take the bulkhead and align it with the left side.

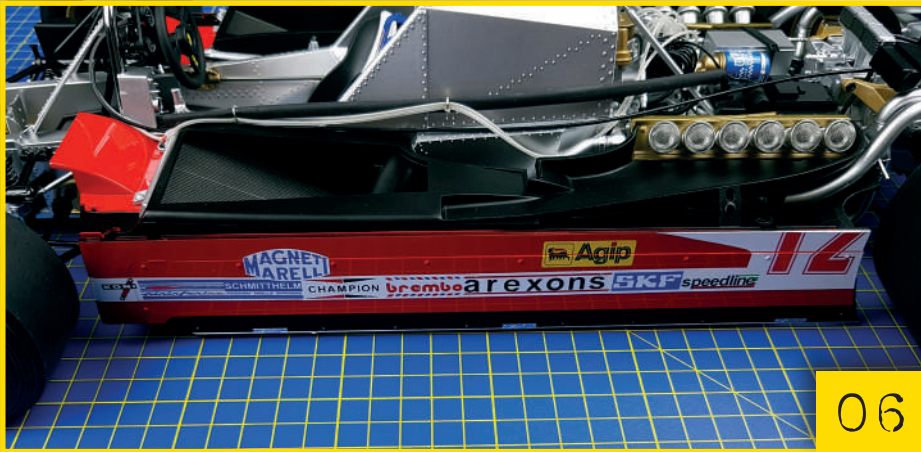

92-06

Press the bulkhead on, so that the four fastening points (D, E, F, G, shown on page 36) all match.

Press gently with your fingers: the bulkhead will slot in immediately.



FINAL RESULT

Your Ferrari 312 T4 model should now look like this.

In the next stage

The parts of the right skirt and outer bulkhead to close the right belly.

