

STEVE MCQUEEN'S ICONIC **PORSCHE** **917KH**



Pack 08

BUILD INSTRUCTIONS

**STAGE 55: ASSEMBLING AND FIXING
THE SEAT BELTS**

**STAGE 56: BUILDING AND ATTACHING
THE CABIN BULKHEAD**

**STAGE 57: FITTING THE RIGHT
VELOCITY STACK PANEL**

**STAGE 58: FITTING THE LEFT
VELOCITY STACK PANEL**

**STAGE 59: FIXING COVERS ONTO THE ENGINE
AND THE VELOCITY STACKS**

**STAGE 60: ATTACHING THE BATTERY
AND THE GEAR LEVER**

STAGE 61: FITTING THE DRIVER SEAT

STAGE 62: FITTING THE PASSENGER SEAT

STAGE 63: DETAILING THE DASHBOARD

**STAGE 64: FITTING THE SWITCHES
AND THE INSTRUMENT PANEL**

Porsche, the Porsche shield and the distinctive design of Porsche cars are trademarks and trade dress of Porsche AG. Permission granted.

The Gulf trademarks are used under license from Gulf Oil International Ltd.

Personality rights of Steve McQueen are used with permission of Chadwick McQueen and The Terry McQueen Testamentary Trust.

Represented exclusively by Greenlight.

AGORA
MODELS

Advice from the experts

Spare screws are included with each part. Occasionally, you may be instructed to keep spare or unused screws for a later stage. Keep these spares in a safe place and label them correctly.

Please make sure you don't mix up the screws. They look quite similar, but the threads do vary slightly. Using the wrong screws may damage the parts.

When securing parts together using multiple screws, fit each screw loosely to ensure all the parts are correctly aligned before gently tightening them firmly, but not overtight, in the order in which you placed them.

The screwdriver can be magnetized by stroking it with a magnet (fridge magnet, etc.) enabling it to hold the screws and make assembly easier.

If a screw is tight going into a metal part, do not force it as you may shear the head off. Remove it and put a tiny smear of Vaseline, soap or light oil on the thread. That will lubricate it and make it easier to drive home.

During the course of this build, you will receive many pieces that you will assemble immediately – following the instructions in the corresponding stage – and other pieces that you should store safely to one side, for use in future assembly stages.

Left and Right! When building your Porsche 917KH, the left or right hand side refers to each side as you are sitting in the car.



WARNING: Some parts are assembled using magnets. These magnets can cause serious injury if they are swallowed. Keep away from children. If you suspect a magnet has been swallowed, seek medical help straight away.

STAGE 55: ASSEMBLING AND FIXING THE SEAT BELTS

55A Plexiglass partition

55B Seat belt support (x2)

55C Seat belt (x2)

55D Top buckle (x2)

55E Bottom buckle (x2)

55F Buckle lock (x2)

55G Double-sided adhesive (x3)

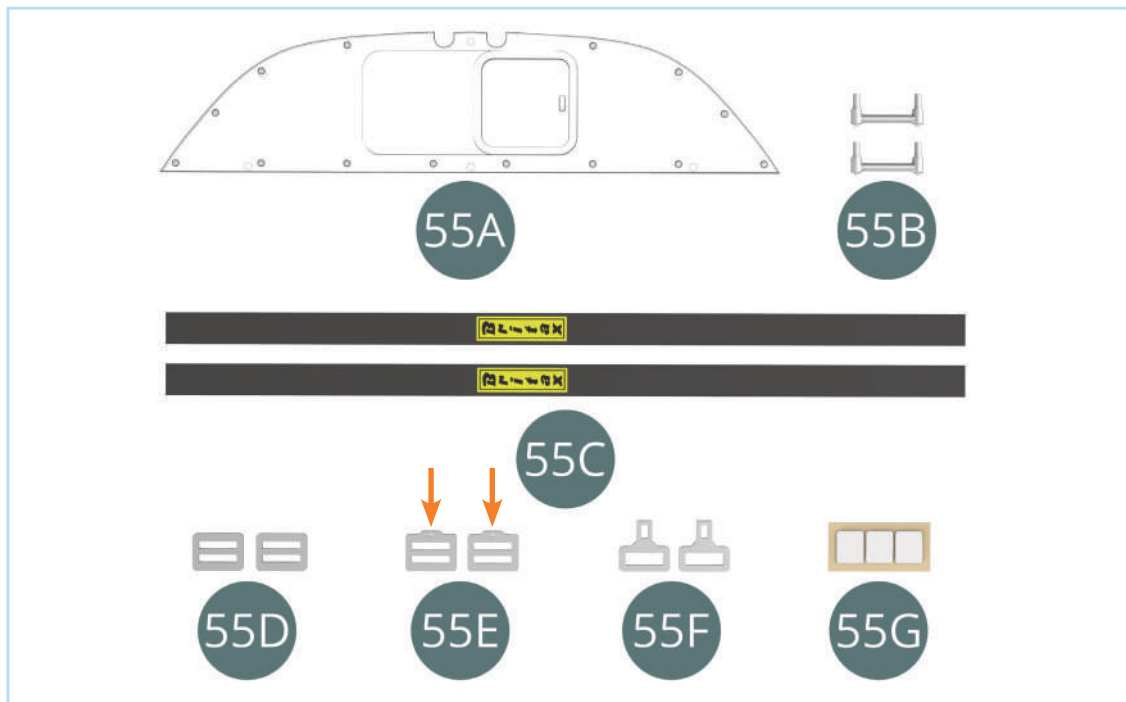

Note the **bottom buckles (55E)** have a tab with a small hole (orange arrows).

ASSEMBLY DIAGRAM

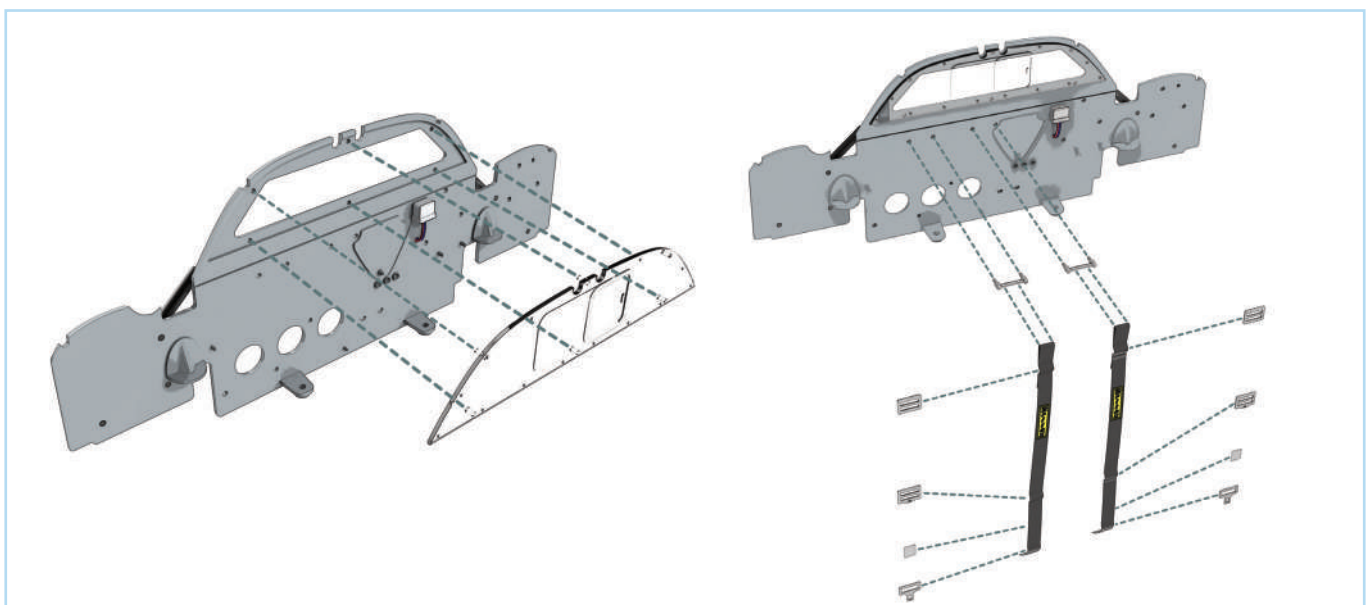

STAGE 55: ASSEMBLING AND FIXING THE SEAT BELTS

STEP 1

Fit the **plexiglass partition (55A)** onto the grey side of the **cabin bulkhead (54A)** by pressing the six pins into the holes.

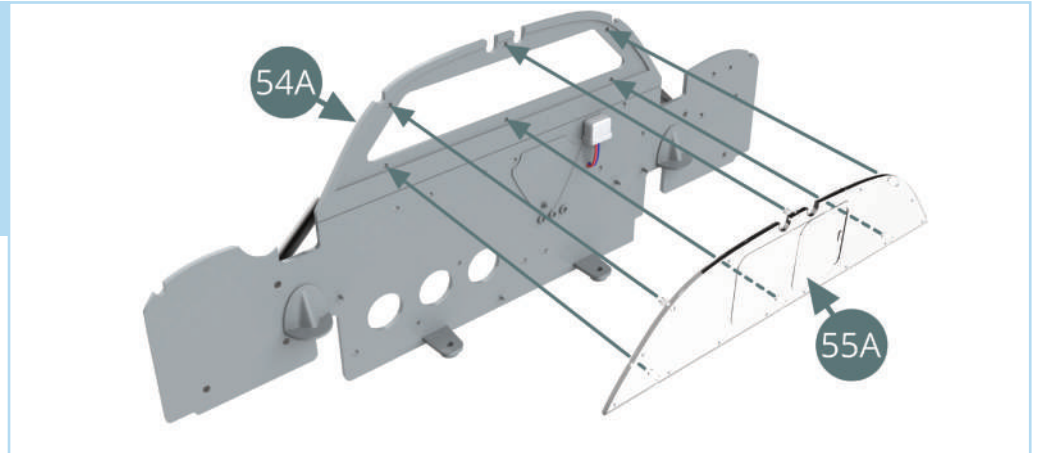

STEP 2

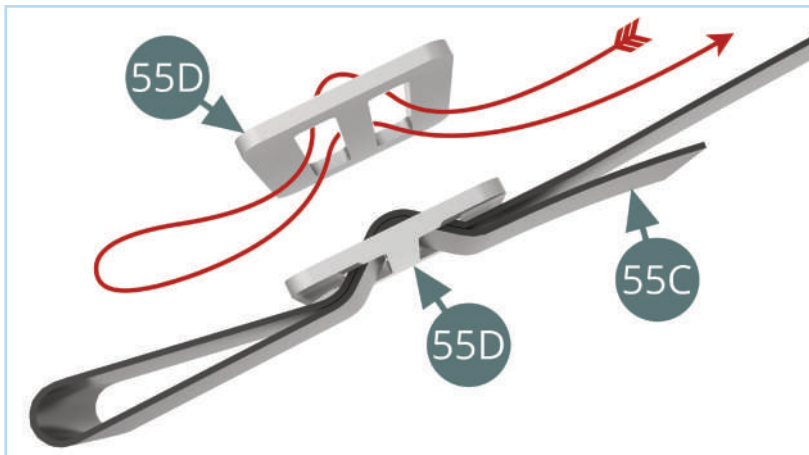

Pass the **seat belt (55C)** through the **top buckle (55D)** as indicated by the red arrows. Repeat this with the second **seat belt (55C)**. You may wish to use a pair of tweezers to assist with pulling the belt through the buckle.

STEP 3

After installing the **top buckle (55D)**, continue in the same way by passing the **seat belt (55C)** through the **bottom buckle (55E)** as shown. Repeat with the second **seat belt (55C)**.

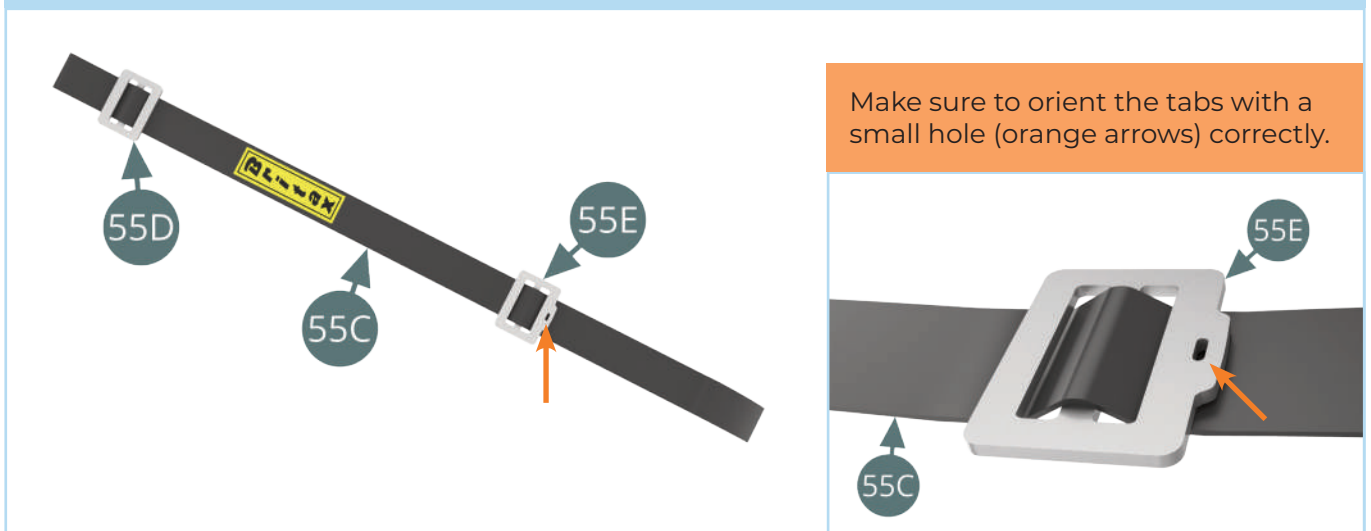

STAGE 55: ASSEMBLING AND FIXING THE SEAT BELTS

STEP 4

Pass the **seat belt (55C)** through the **buckle lock (55F)**. Apply **double-sided adhesive (55G)** to the end of the **seat belt (55C)**. Remove the backing paper (red arrow) from the adhesive, then fold the belt over and stick the free end (blue arrow) so that it holds the buckle lock.

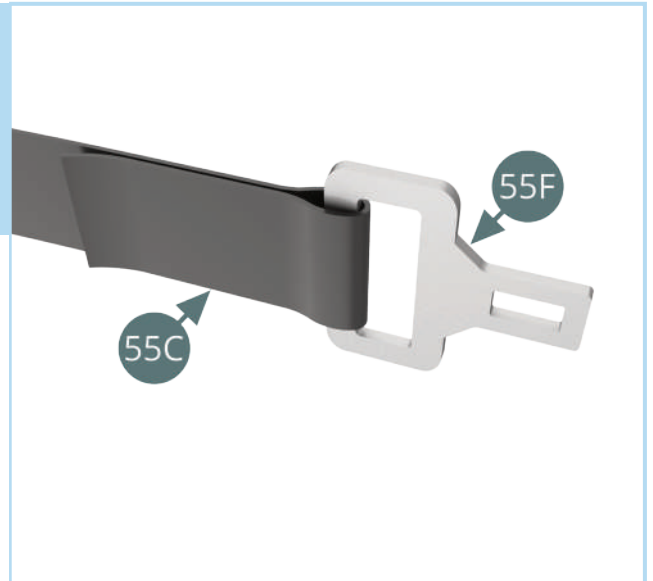
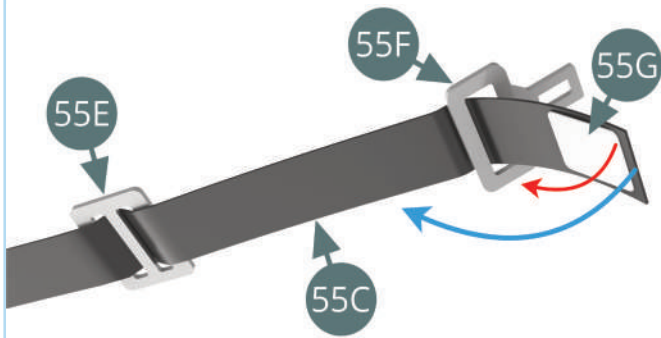

Repeat this step for the second seat belt.

The two seat belts should look like this once assembled.

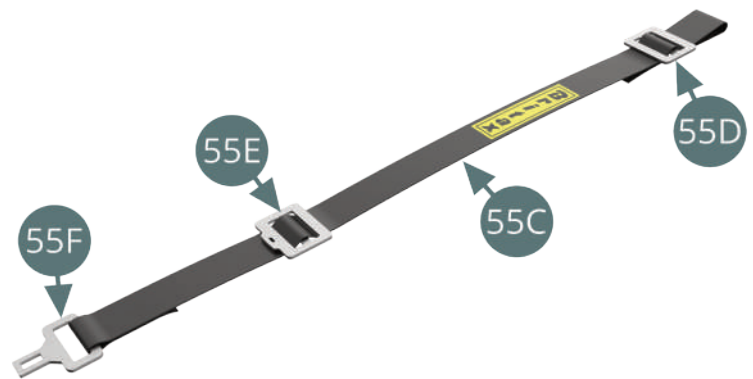

STEP 5

Pass the **seat belt supports (55B)** through the buckles at the upper end of the **seat belts (55C)**.

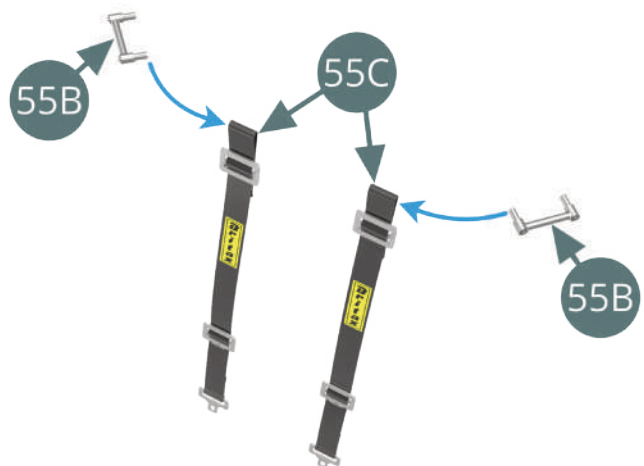

STAGE 55: ASSEMBLING AND FIXING THE SEAT BELTS

STEP 6

Position the two **seat belt supports (55B)** on the grey side of the **cabin bulkhead (54A)**.

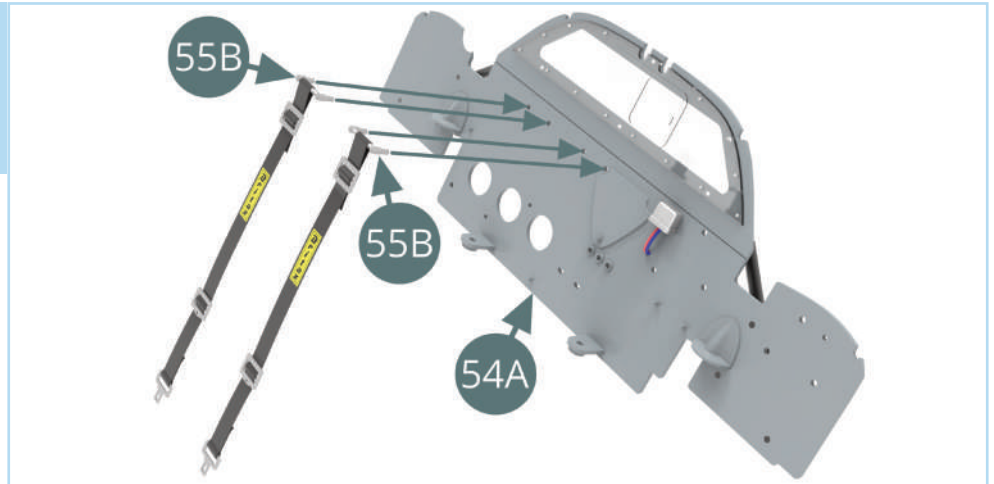

STAGE COMPLETE

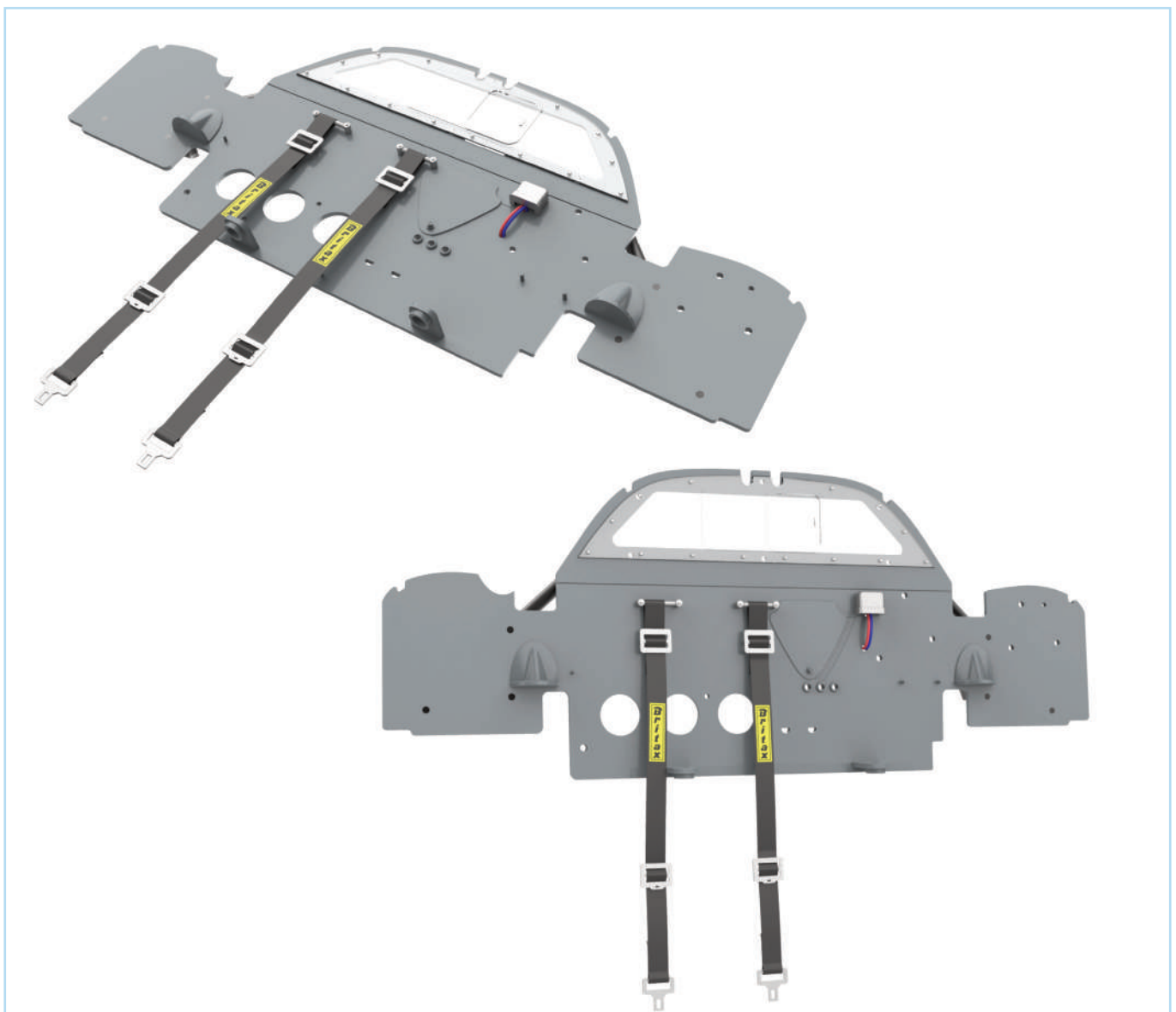

STAGE 56: BUILDING AND ATTACHING THE CABIN BULKHEAD

- 56A** Ignition coil (x2)
- 56B** Black cable
- 56C** Red cable
- 56D** Black cable sheath
- 56E** White cable
- 56F** Red cable
- 56G** Yellow cable
- 56H** Blue cable
- 56I** Brown cable
- 56J** Black cable
- 56K** Ignition box
- 56L** Ignition box
- 56M** Rev limiter relay
- 56N** Regulator housing (bottom)
- 56O** Fire extinguisher
- 56P** Fire extinguisher
- 56Q** Branch connector
- 56R** Fire extinguisher hose
- 56S** Adhesive tape (x6)
- 56T** Regulator housing (top)
- BM** Screw 2 x 4 mm (x3)

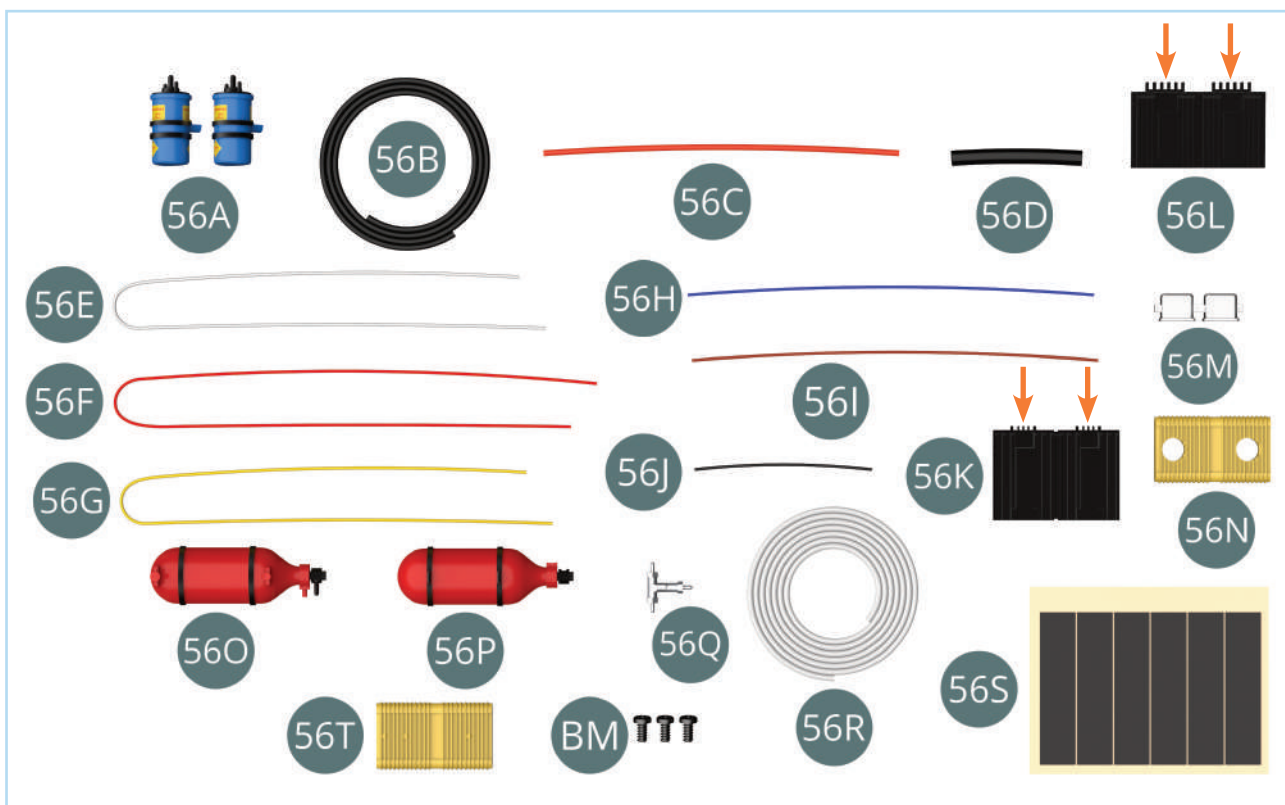

To help differentiate the two **ignition boxes (56K and 56L)** from each other, note that **56L** is smaller than **56K**. The pins on top are also different sizes (orange arrows).

Your **white cable (56E)** may be more grey in appearance, but this will not affect its function.

STAGE 56: BUILDING AND ATTACHING THE CABIN BULKHEAD

ASSEMBLY DIAGRAM

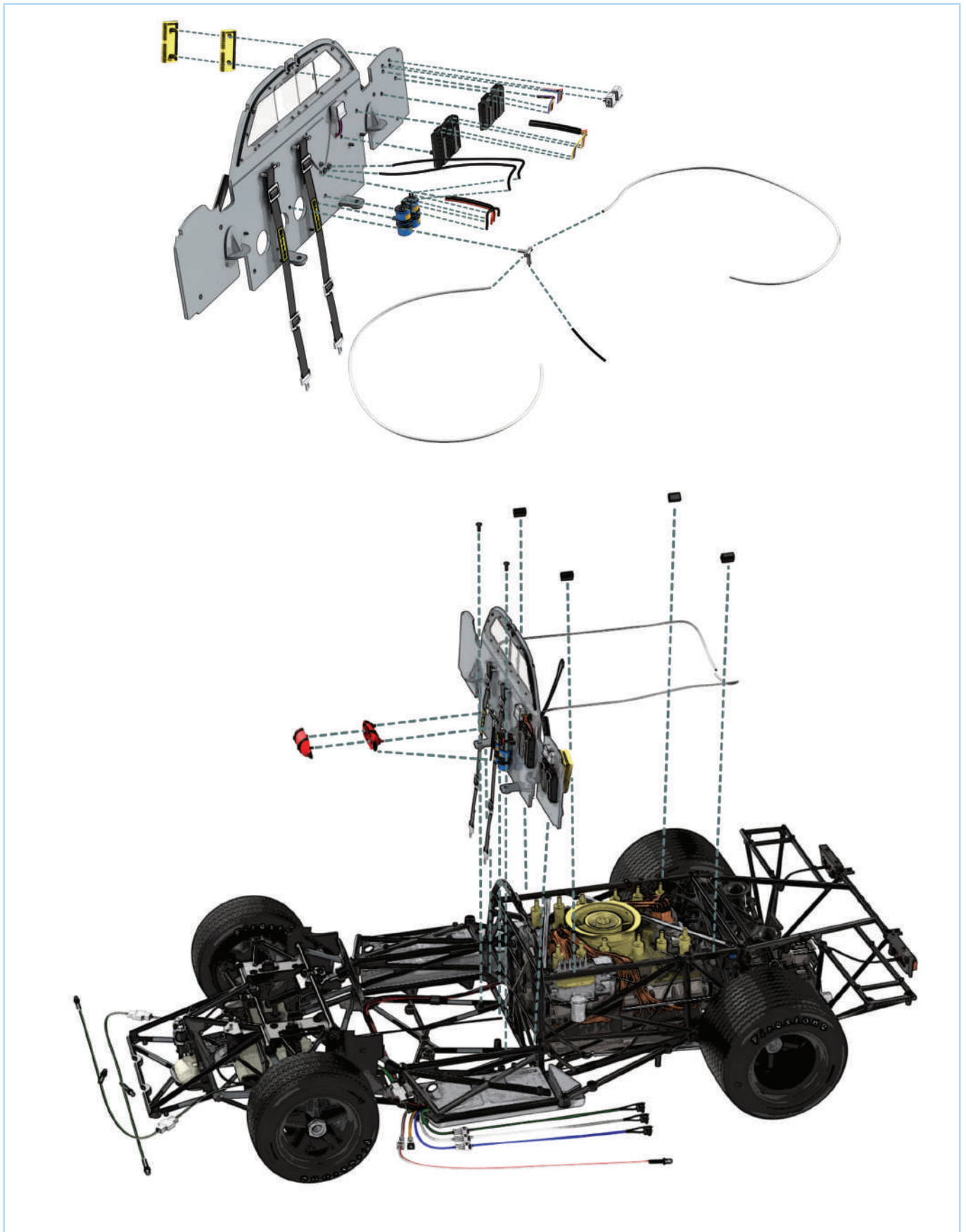

STAGE 56: BUILDING AND ATTACHING THE CABIN BULKHEAD

STEP 1

Fit the smaller **ignition box (56L)** on the **cabin bulkhead (54A)** by pressing the two pins into the holes. Cut the thin cables into the quantities and lengths as shown in the below right image.

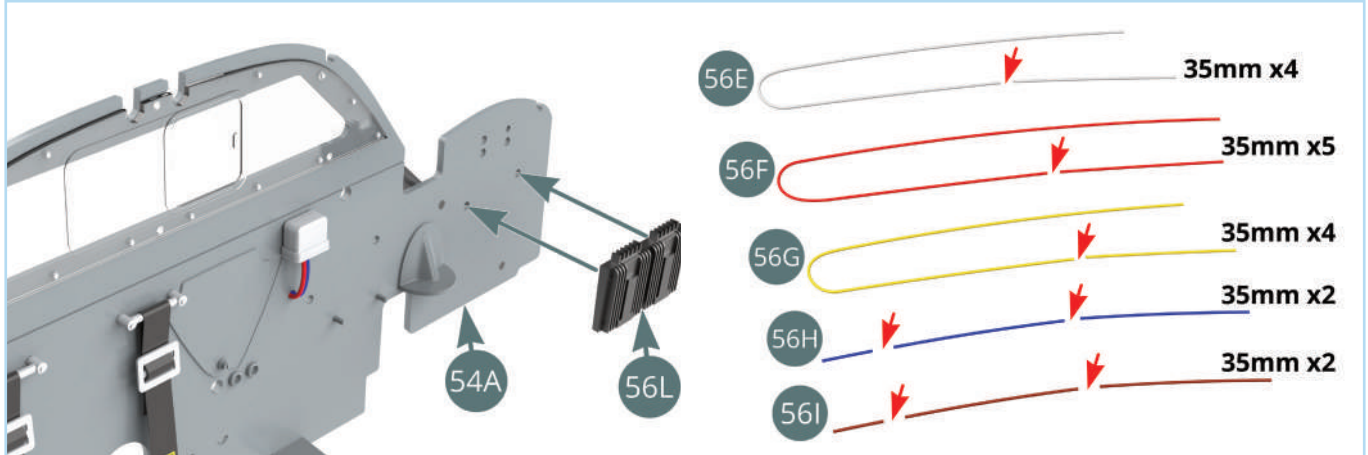

STEP 2

Insert the cut **white (56E)**; **red (56F)**; **yellow (56G)**; **blue (56H)** and **brown (56I)** wires into the two lower openings of the **cabin bulkhead (54A)**, then connect their ends to the slots between the pins located on top of the **ignition box (56L)** (bottom image).

You may need to apply a small amount of super glue to the ends of the cables before inserting them into the slots.

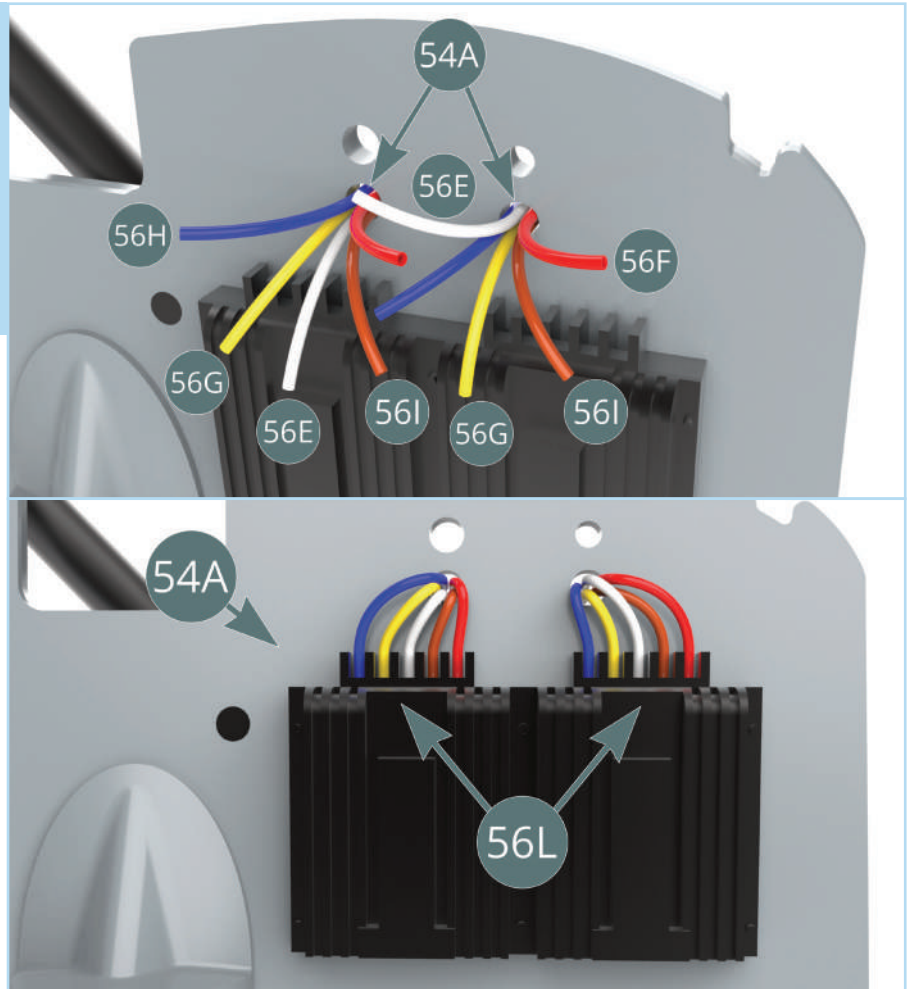

STAGE 56: BUILDING AND ATTACHING THE CABIN BULKHEAD

STEP 3

Press the pins of the **rev limiter relay (56M)** into the **cabin bulkhead (54A)**.

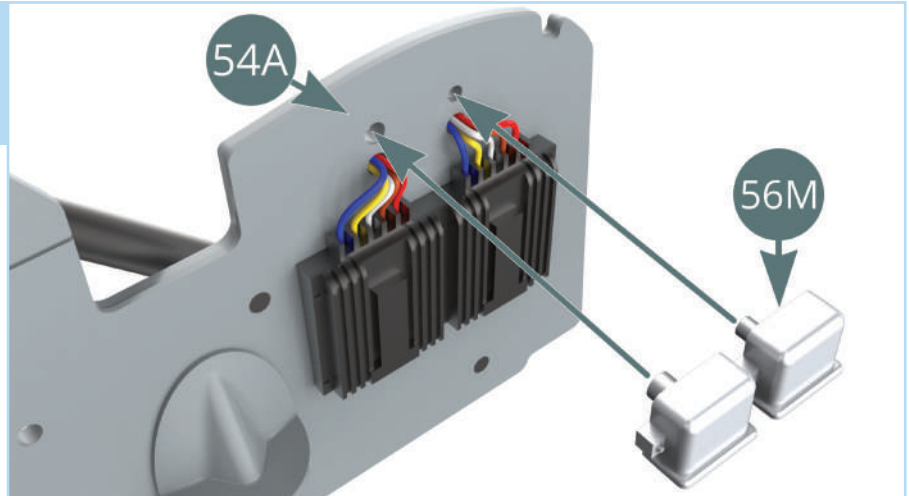

Fit the larger **ignition box (56K)** into the **cabin bulkhead (54A)** as shown.

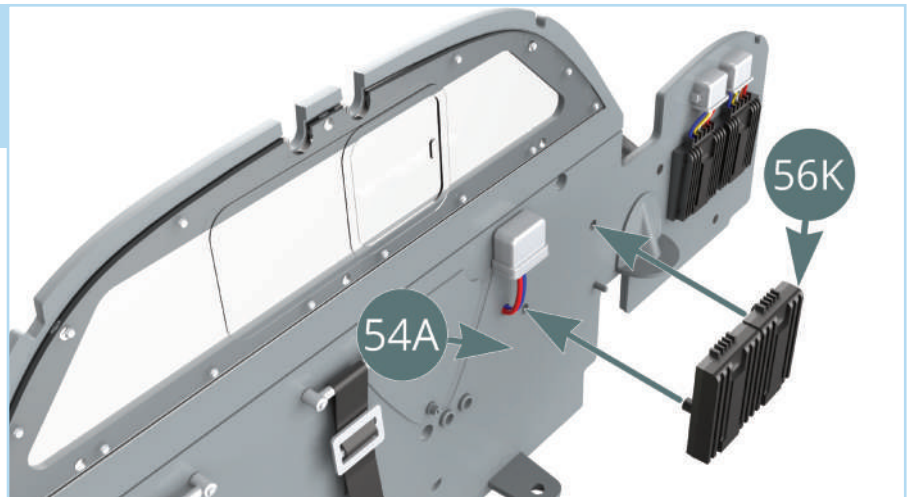

STEP 4

Insert the remaining **white (56E)**, **red (56F)**, and **yellow (56G)** cables previously cut, as well as the **black cable (56J)**, into the **black cable sheath (56D)**.

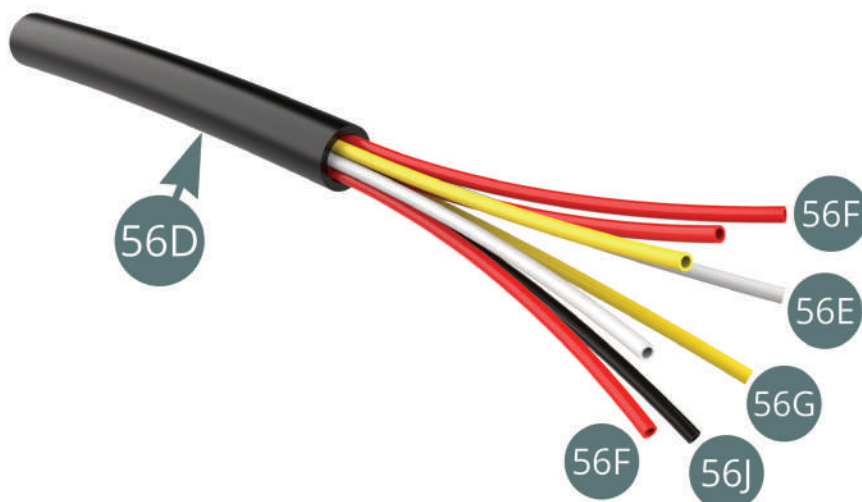

STAGE 56: BUILDING AND ATTACHING THE CABIN BULKHEAD

Push the ends of the cables and the **black cable sheath (56D)** through the opening in the **cabin bulkhead (54A)**, above the **ignition box (56K)**.

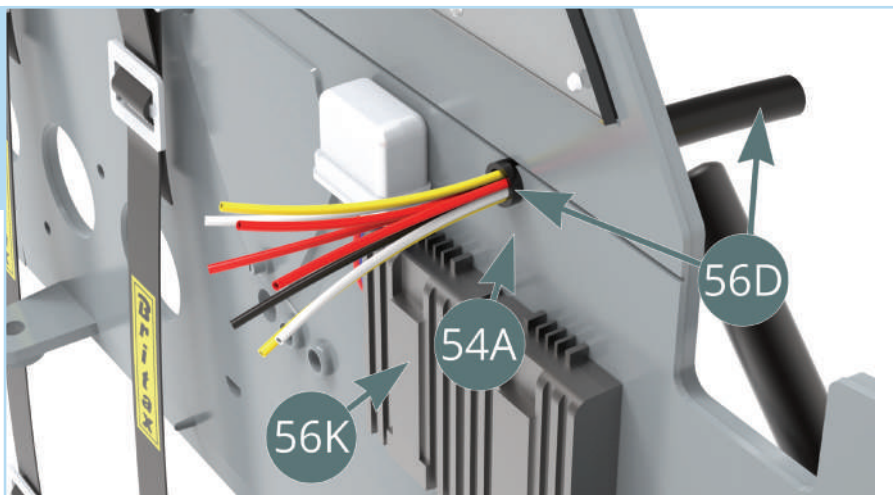

STEP 5

Connect the ends of the yellow, white, red and black cables to the slots between the pins of the **ignition box (56K)** as shown.

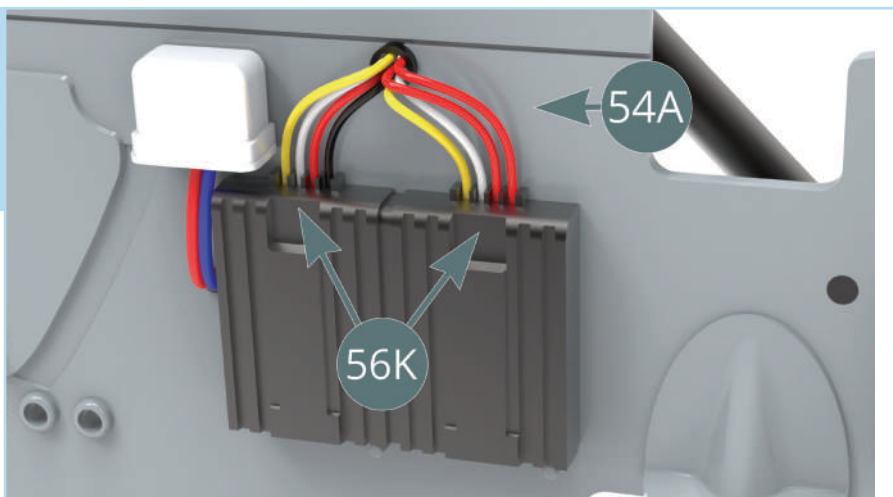

Turn the **cabin bulkhead (54A)** around to the silver side and cut the protruding wires and **black cable sheath (56D)** flush with the bulkhead, as shown by the red arrows.



STAGE 56: BUILDING AND ATTACHING THE CABIN BULKHEAD

STEP 6

Fit the pins of the top **regulator housing (56T)** into the holes of the bottom **regulator housing (56N)** and press into the **cabin bulkhead (54A)** as shown.

The fitting is not identical either side. Ensure the hole closer to the edge (orange arrow) is over the lower column. Test fit the parts before pushing into place.

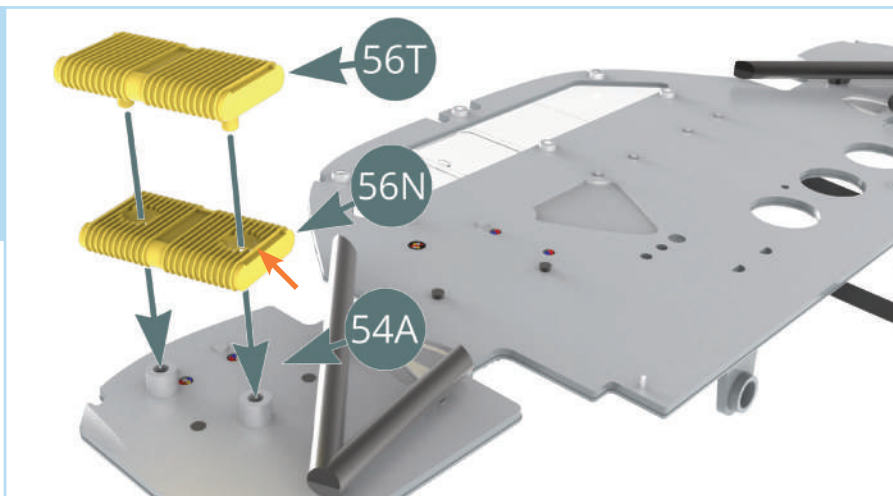

Press the two **ignition coils (56A)** into the D-shaped holes of the **cabin bulkhead (54A)**.

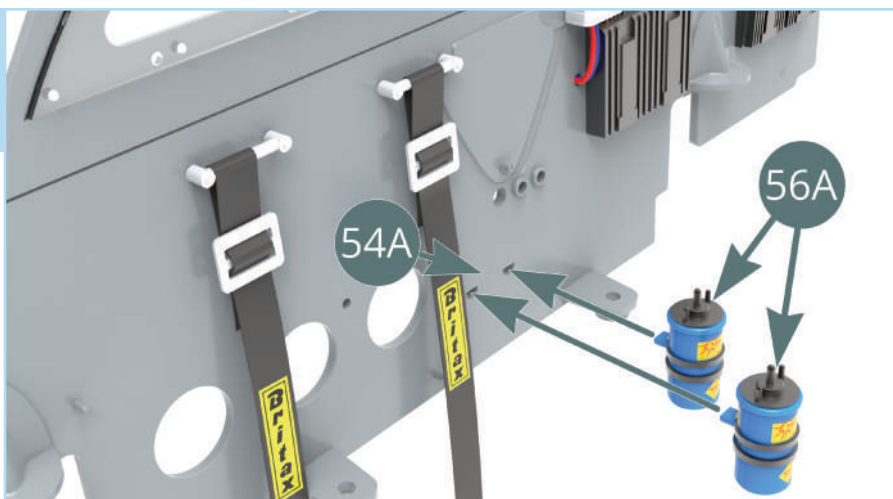

STEP 7

Cut two lengths of 30mm of the thick **red cable (56C)** as shown below, then cut the quantities and lengths of the thick **black cable (56B)** as detailed opposite.

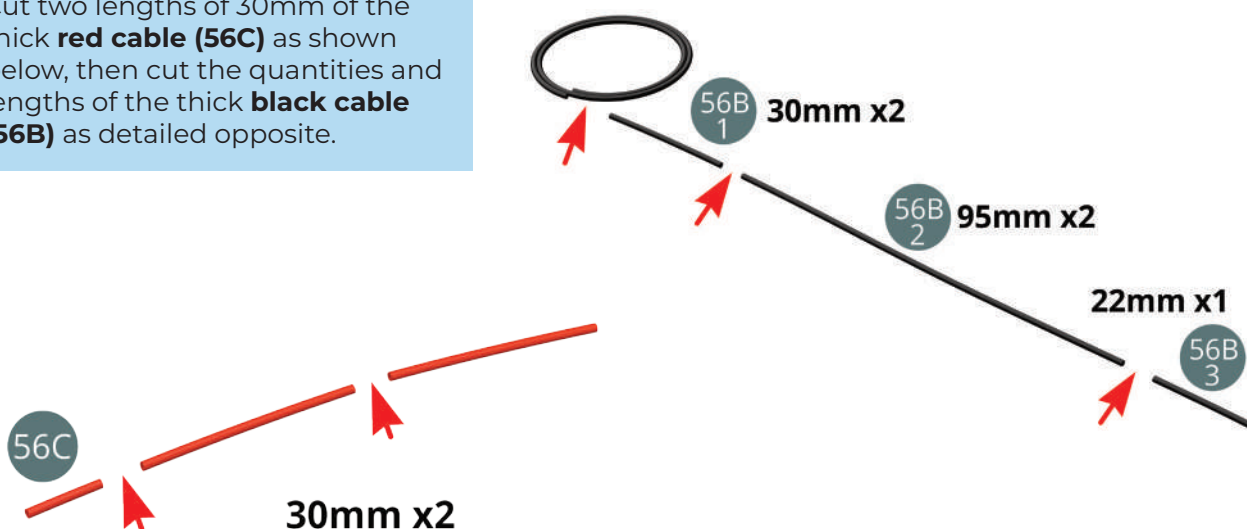

STAGE 56: BUILDING AND ATTACHING THE CABIN BULKHEAD

STEP 8

Fit the 30mm lengths of **red cable (56C)** and **black cable (56B-1)** to the pins at the edges of the **ignition coils (56A)** as shown, then feed the ends of the cables through the left opening in the **cabin bulkhead (54A)**.

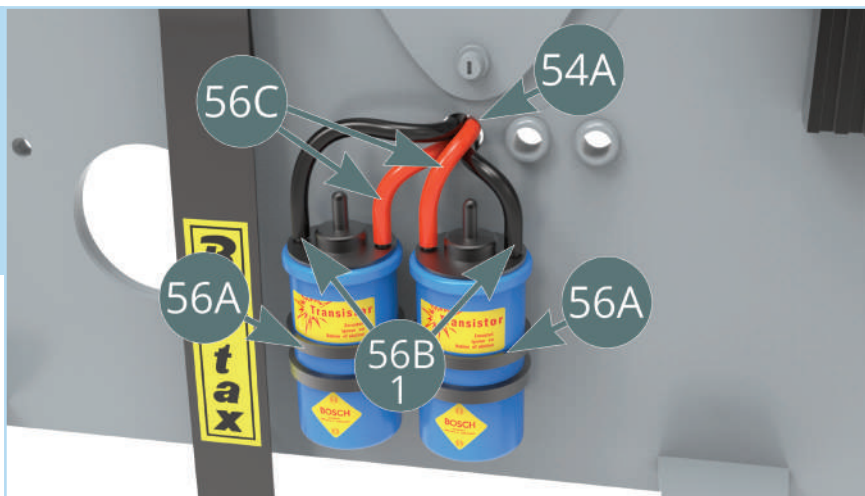

Fit the 95mm lengths of **black cable (56B-2)** to the pins in the middle of the **ignition coils (56A)** as shown, then feed the ends of the cables through the middle and right openings in the **cabin bulkhead (54A)**.



STEP 9

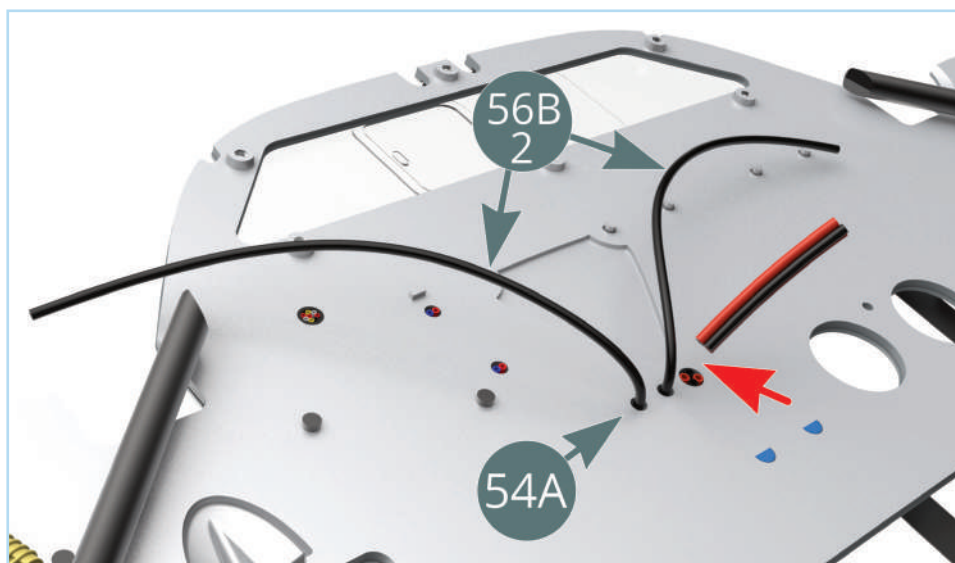

Leave the two **black cable lengths (56B-2)** free for a later step. Cut the red and black cables protruding from the other side of the **cabin bulkhead (54A)** flush with the bulkhead, as shown by the red arrow.

STAGE 56: BUILDING AND ATTACHING THE CABIN BULKHEAD

Fit the 22mm length of **black cable (56B-3)** to the end of the **branch connector (56Q)** as shown, then press it into the grey side of the **cabin bulkhead (54A)**.

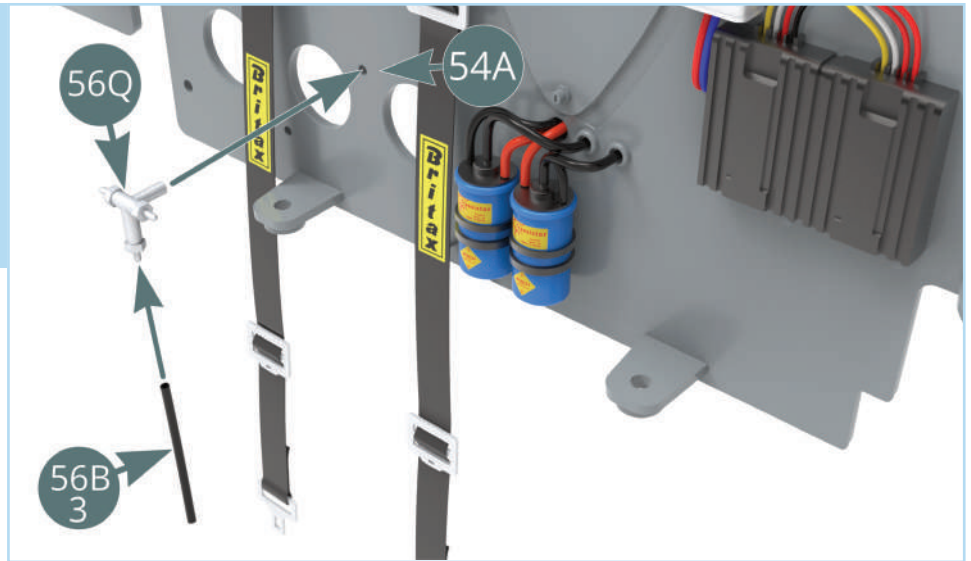

STEP 10

Cut two lengths of 250mm from the **fire extinguisher hose (56R)**.



Connect the two lengths of **fire extinguisher hose (56R)** to the pins on the sides of the **branch connector (56Q)**.



STAGE 56: BUILDING AND ATTACHING THE CABIN BULKHEAD

STEP 11

Take the ends of the two **fire extinguisher hoses (56R)** and pass them through the two large openings (orange arrows) in the **cabin bulkhead (54A)** so that they exit through to the silver side, as shown in the bottom image.

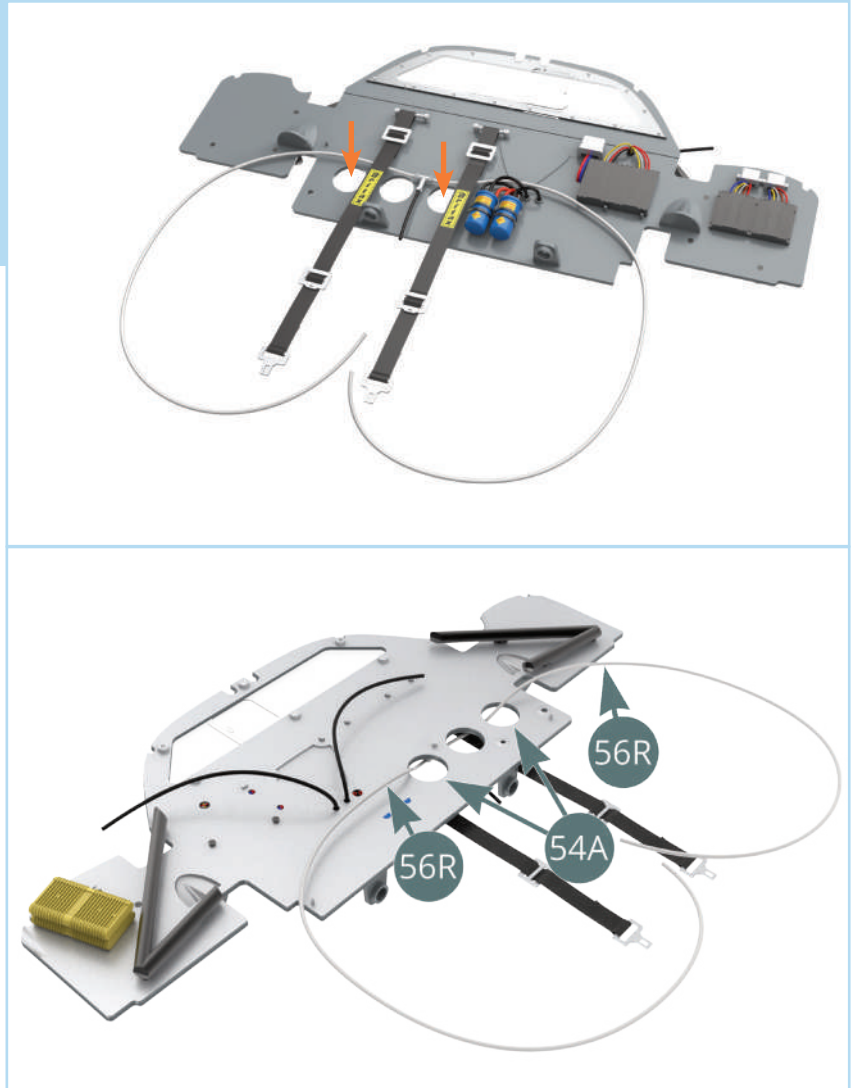

The cabin bulkhead is now ready to be installed on the chassis.

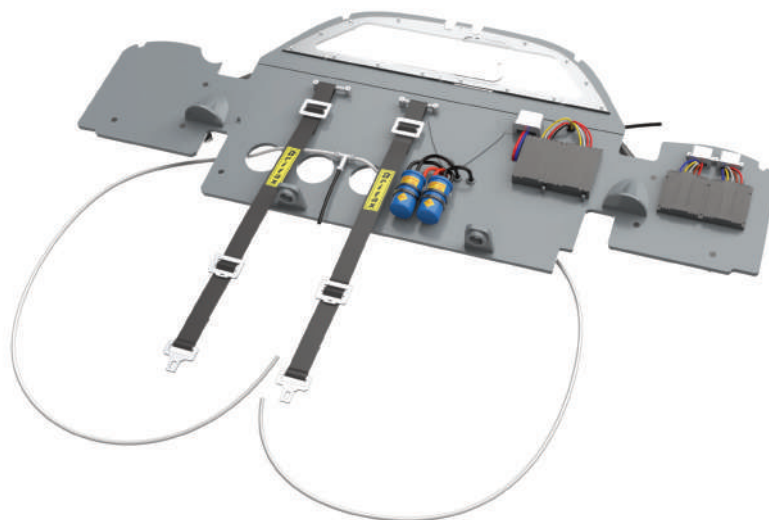

STAGE 56: BUILDING AND ATTACHING THE CABIN BULKHEAD

STEP 12

Take the chassis assembly and place it on your work surface, then align the **cabin bulkhead (54A)** with it as shown.

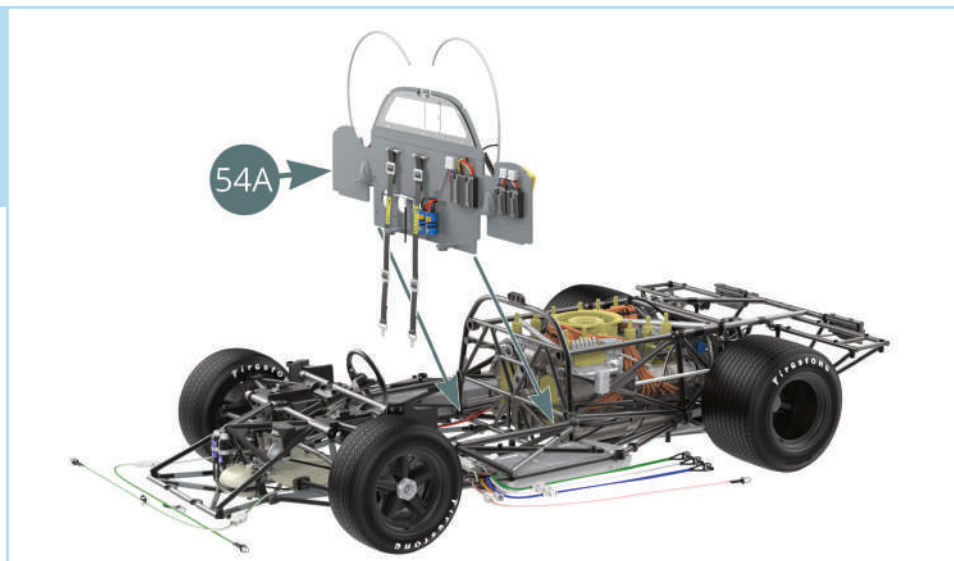

STEP 13

Before attaching the **cabin bulkhead (54A)** to the chassis, connect the two **brake lines (40F)** to the two pins at the bottom of the bulkhead (red arrows). Then run the two **fire extinguisher hoses (56R)** along the upper side tubes of the engine cradle, as indicated by the green arrows. Finally, guide the ends of the two **black cables (56B-2)** towards the **plug lead connectors (22C)** on the distributor cap, as shown by the blue arrows.

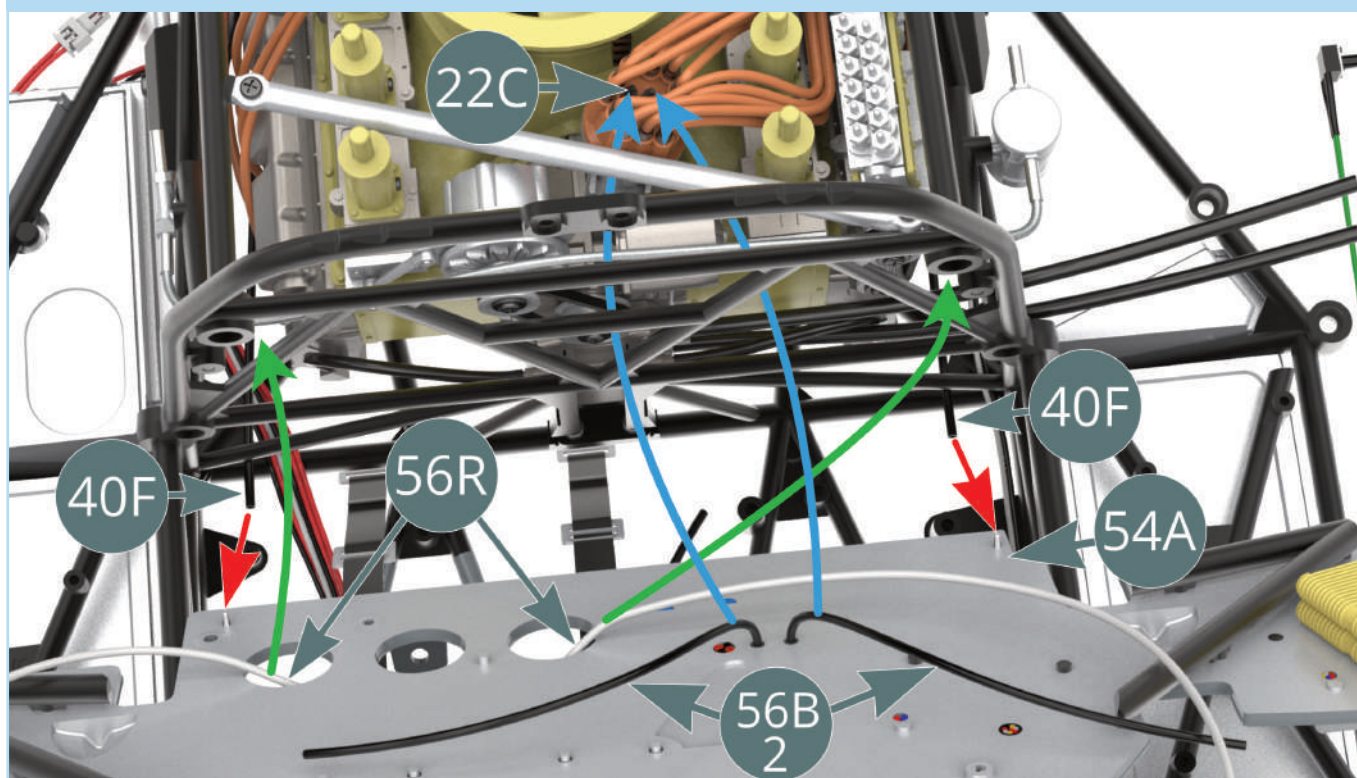

STAGE 56: BUILDING AND ATTACHING THE CABIN BULKHEAD

The **fire extinguisher hoses (56R)** are threaded through the triangular sections of the frame (red dotted line) and run towards the rear of the engine as shown.

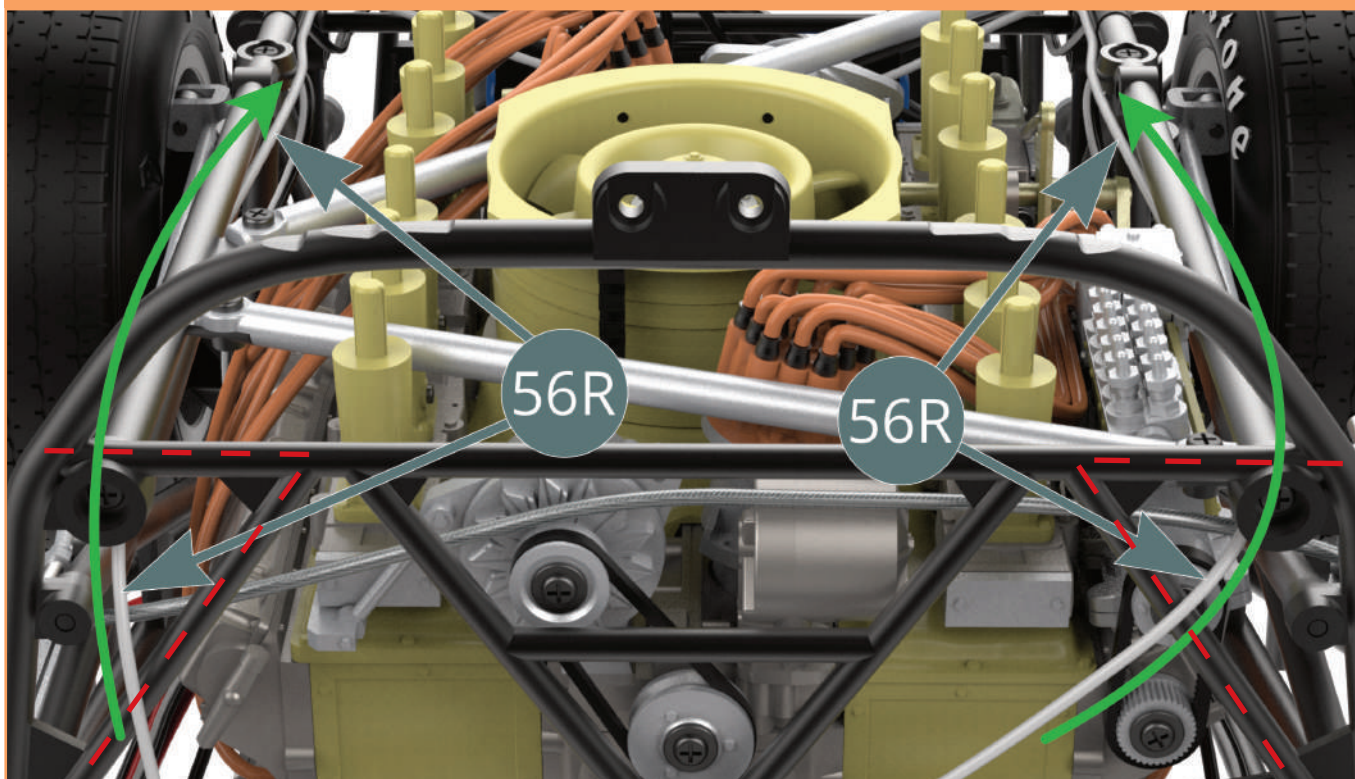

STEP 14

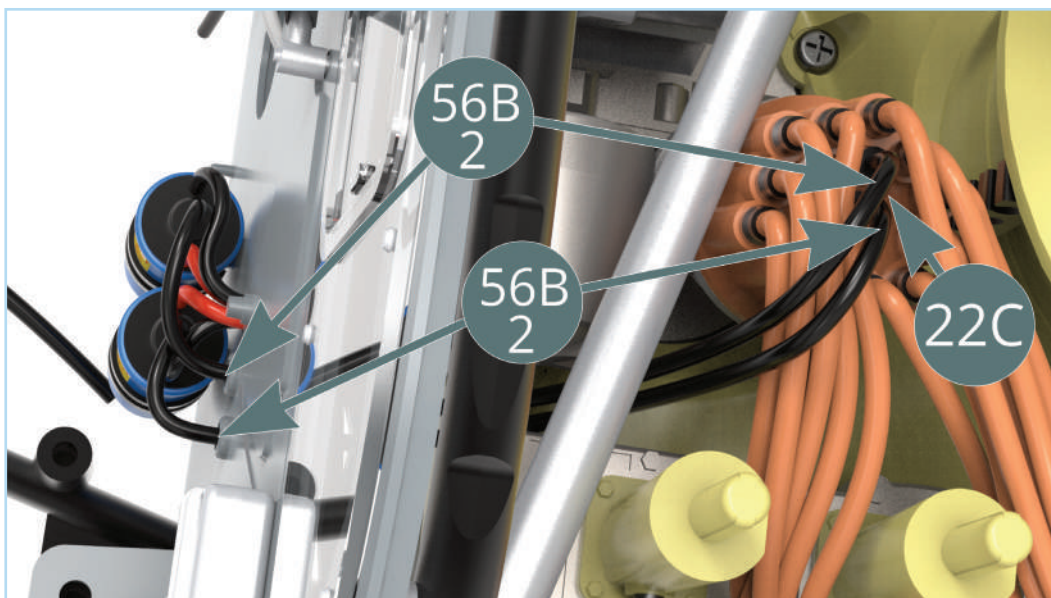

Connect the ends of the **black wires (56B-2)** to the two free **plug lead connectors (22C)**.

If it is difficult to get the ends of the wires to fit over the connectors, you can widen the holes in the wires using a cocktail stick. You can also file the connectors slightly to allow the ends of the wires to fit more easily. You may find it easier to fit the cables by removing the entire distributor cap first.

STAGE 56: BUILDING AND ATTACHING THE CABIN BULKHEAD

STEP 15

Fix the **cabin bulkhead (54A)** to the **chassis (25A)** using two of the **BM** screws. Press the two halves of the **fire extinguisher (56O and 56P)** together.

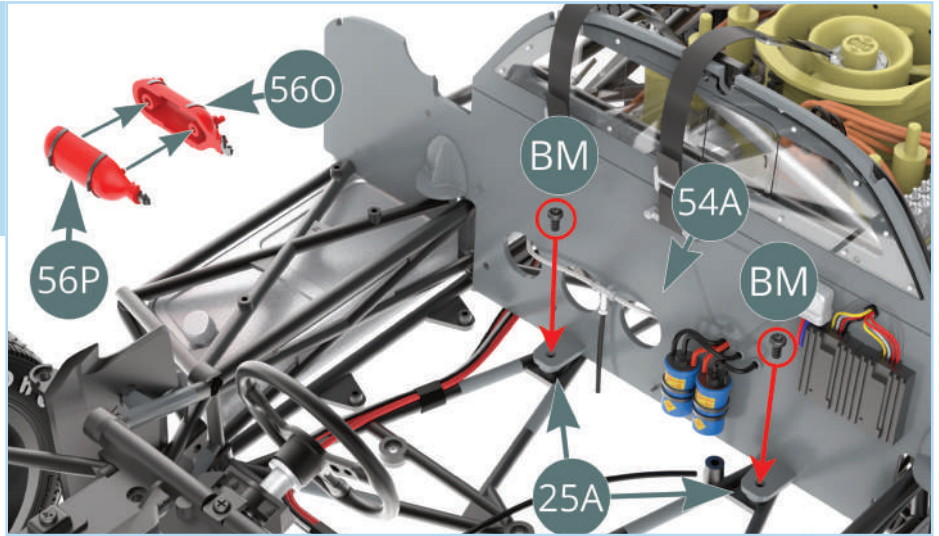

STEP 16

Connect the **black cable (56B-3)** to the black pin of the **fire extinguisher (56O)** then fit it into the small and large hole of the **cabin bulkhead (54A)**. Finally, connect the **clutch cable (26J)** to the pin on the **cabin bulkhead (54A)** as shown.

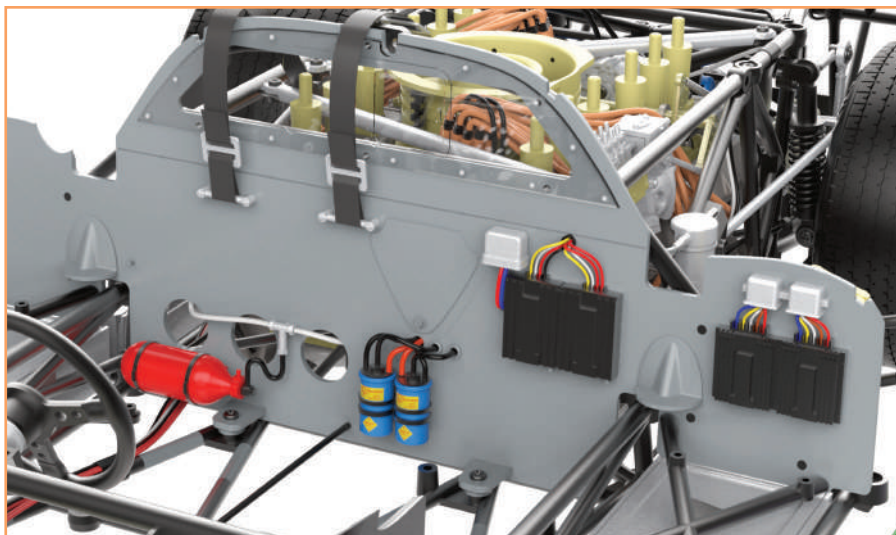

The cabin bulkhead has been attached to the chassis.

STAGE 56: BUILDING AND ATTACHING THE CABIN BULKHEAD

STEP 17

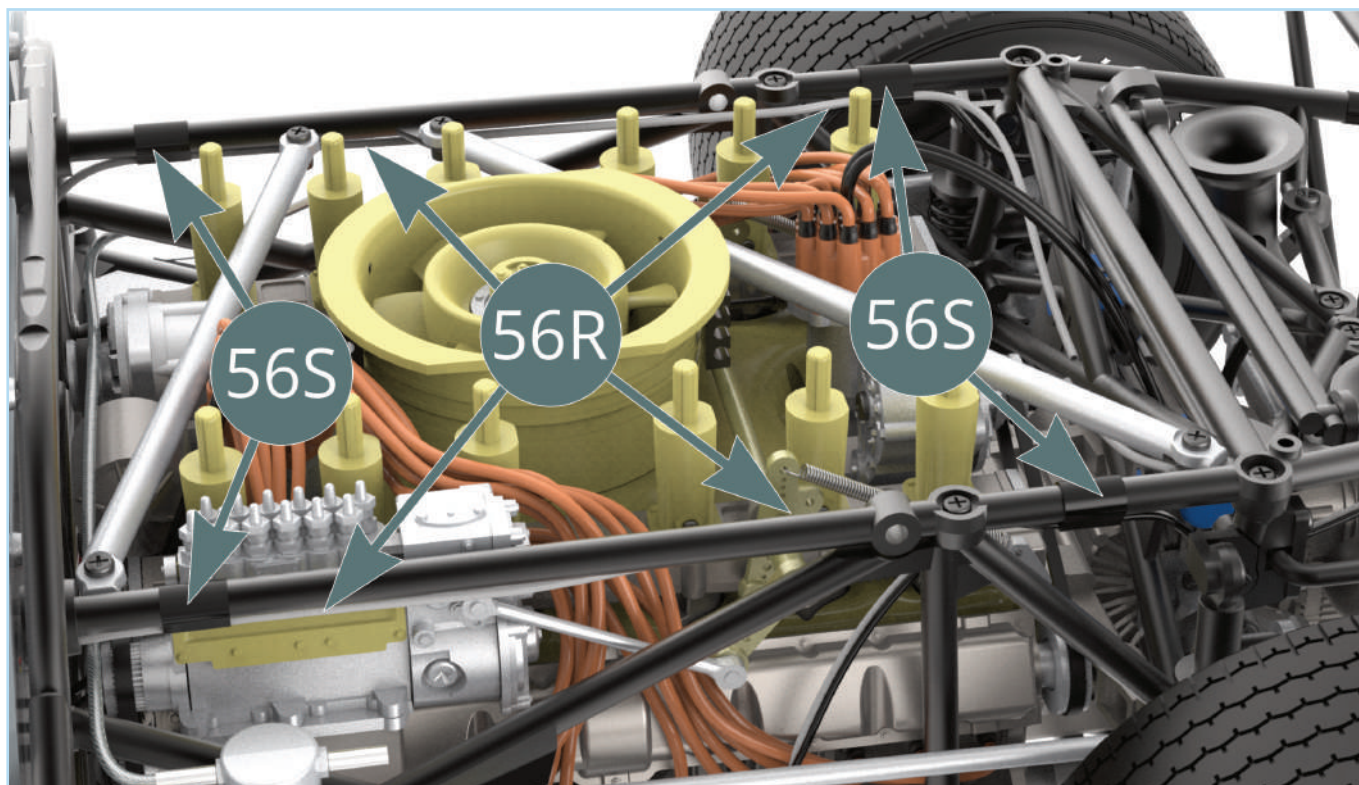

Run the **fire extinguisher hose (56R)** along the two upper lateral tubes of the frame then attach the hose to it using four pieces of **adhesive tape (56S)** as shown in the image.

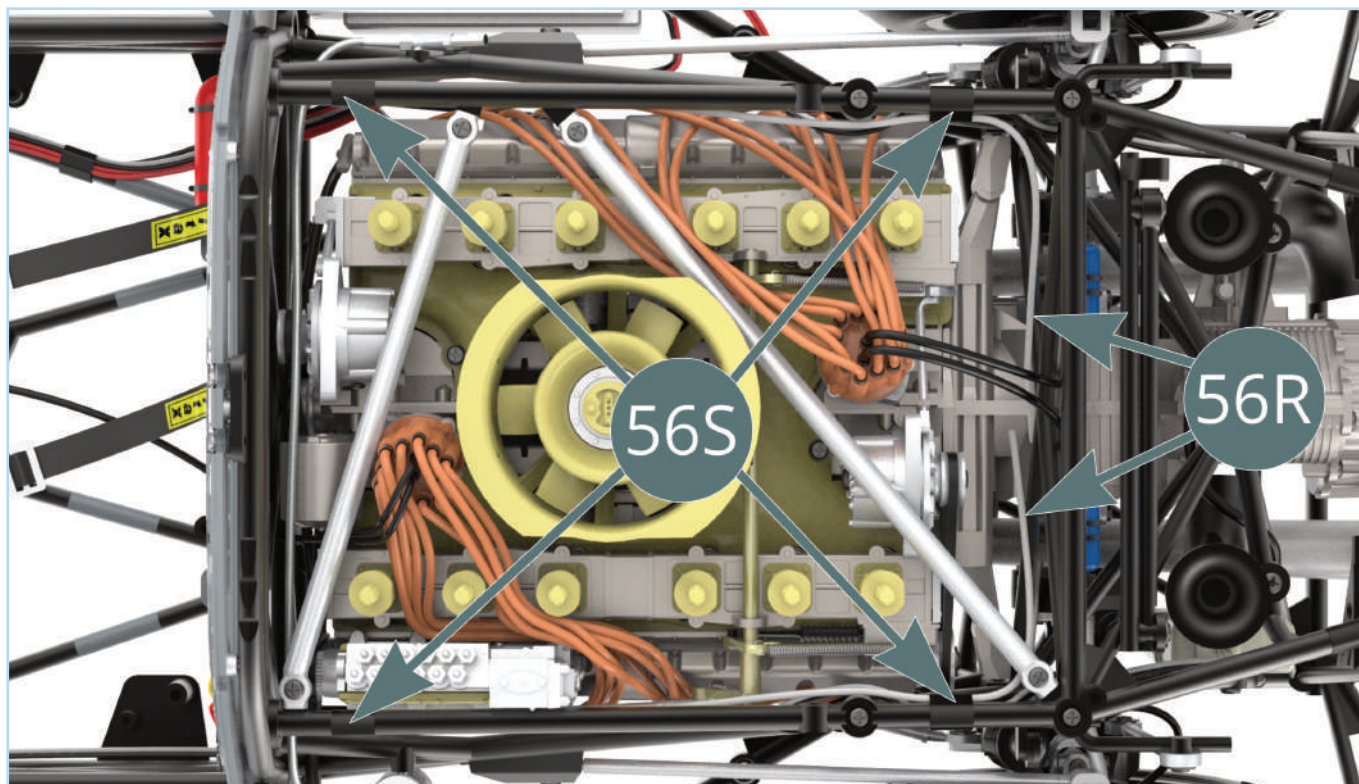

Once the hose is attached, leave both ends at the top rear of the engine as shown.

STAGE 56: BUILDING AND ATTACHING THE CABIN BULKHEAD

STAGE COMPLETE

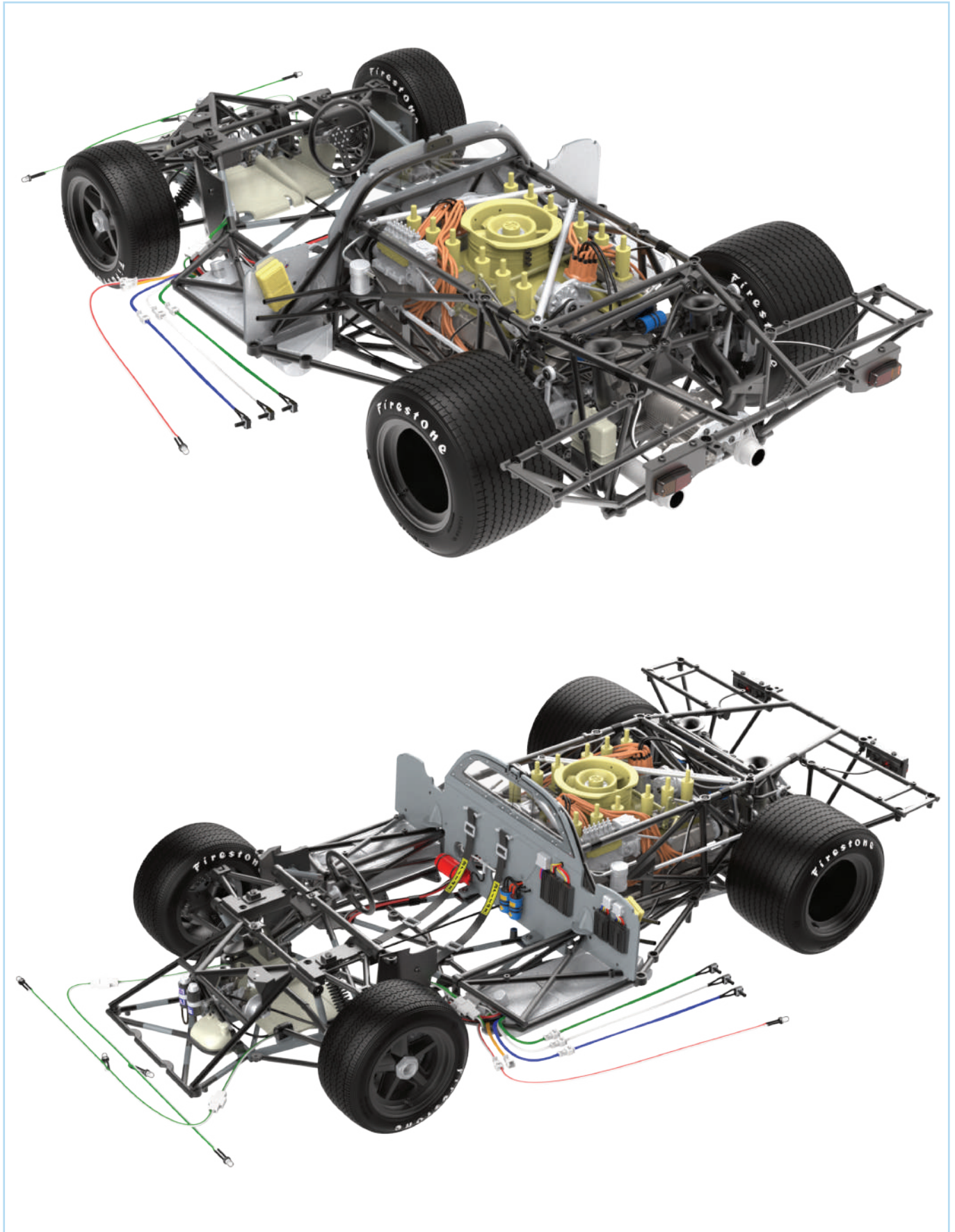

STAGE 57: FITTING THE RIGHT VELOCITY STACK PANEL

57A Velocity stack panel (right)

57B Velocity stack cover (x6)

57C Velocity stack neck (x6)

57D Intake nozzle (x6)

57E Fuel line

57F Fuel line guide

IM Screw 1.7 x 3.5 mm (x3)

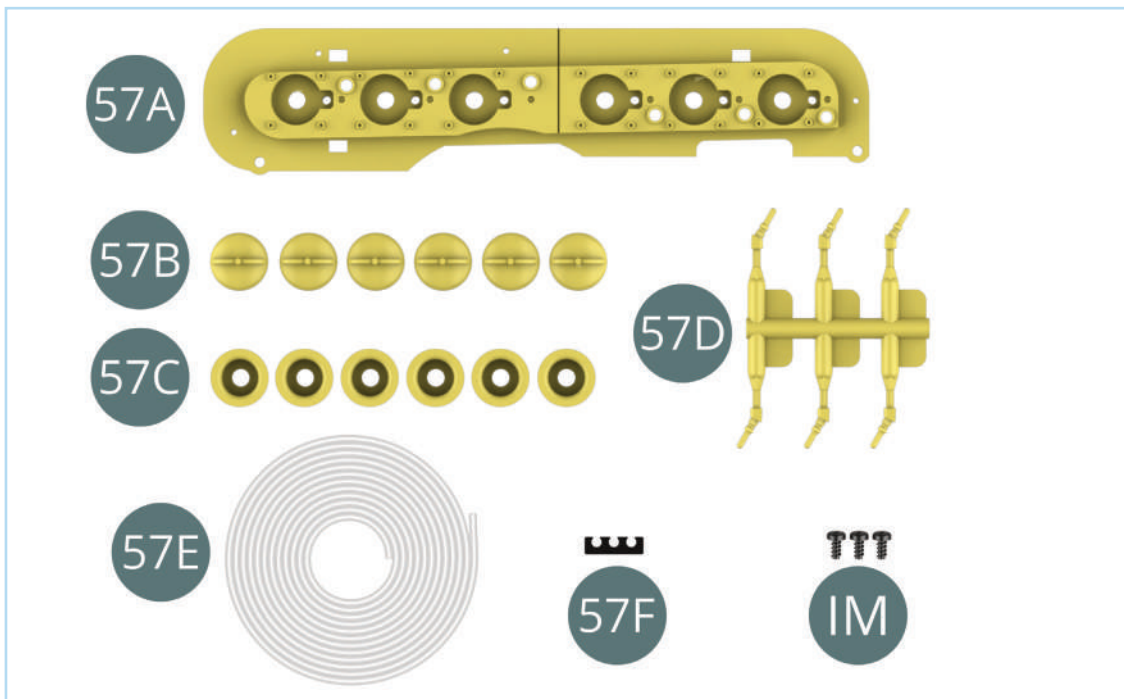

The **intake nozzles (57D)** have been updated and are now a silver colour instead of the yellow shown here. Similarly, the **fuel line (57E)** is translucent yellow.

ASSEMBLY DIAGRAM

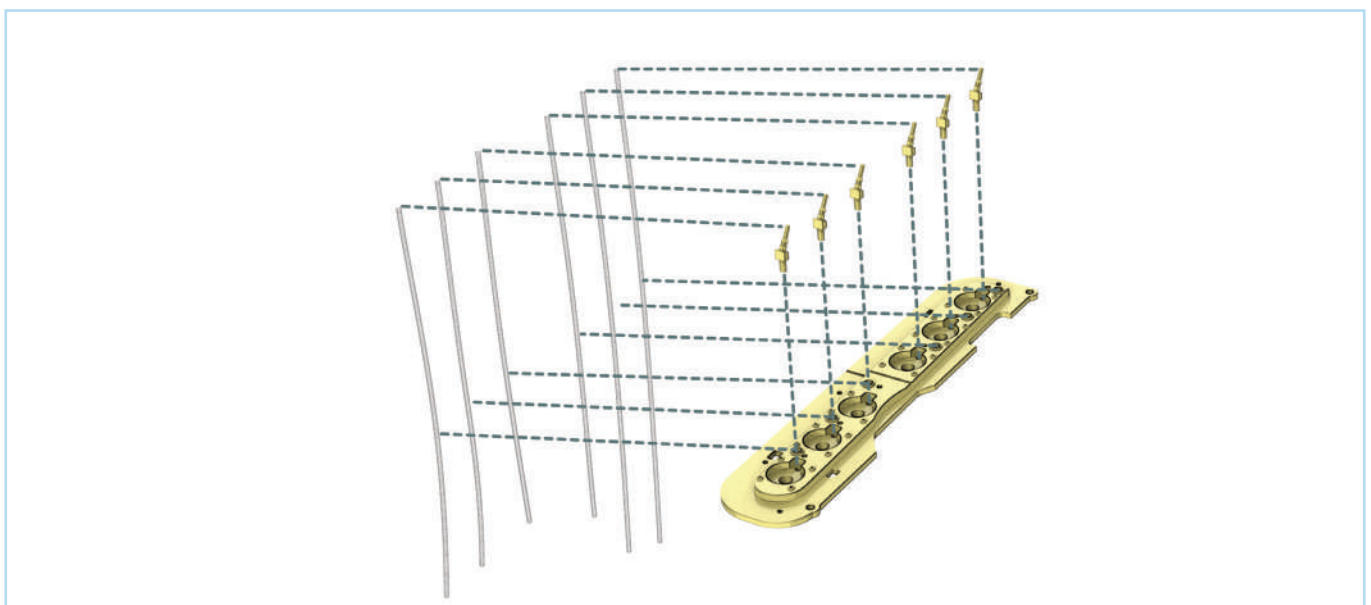

STAGE 57: FITTING THE RIGHT VELOCITY STACK PANEL

ASSEMBLY DIAGRAM

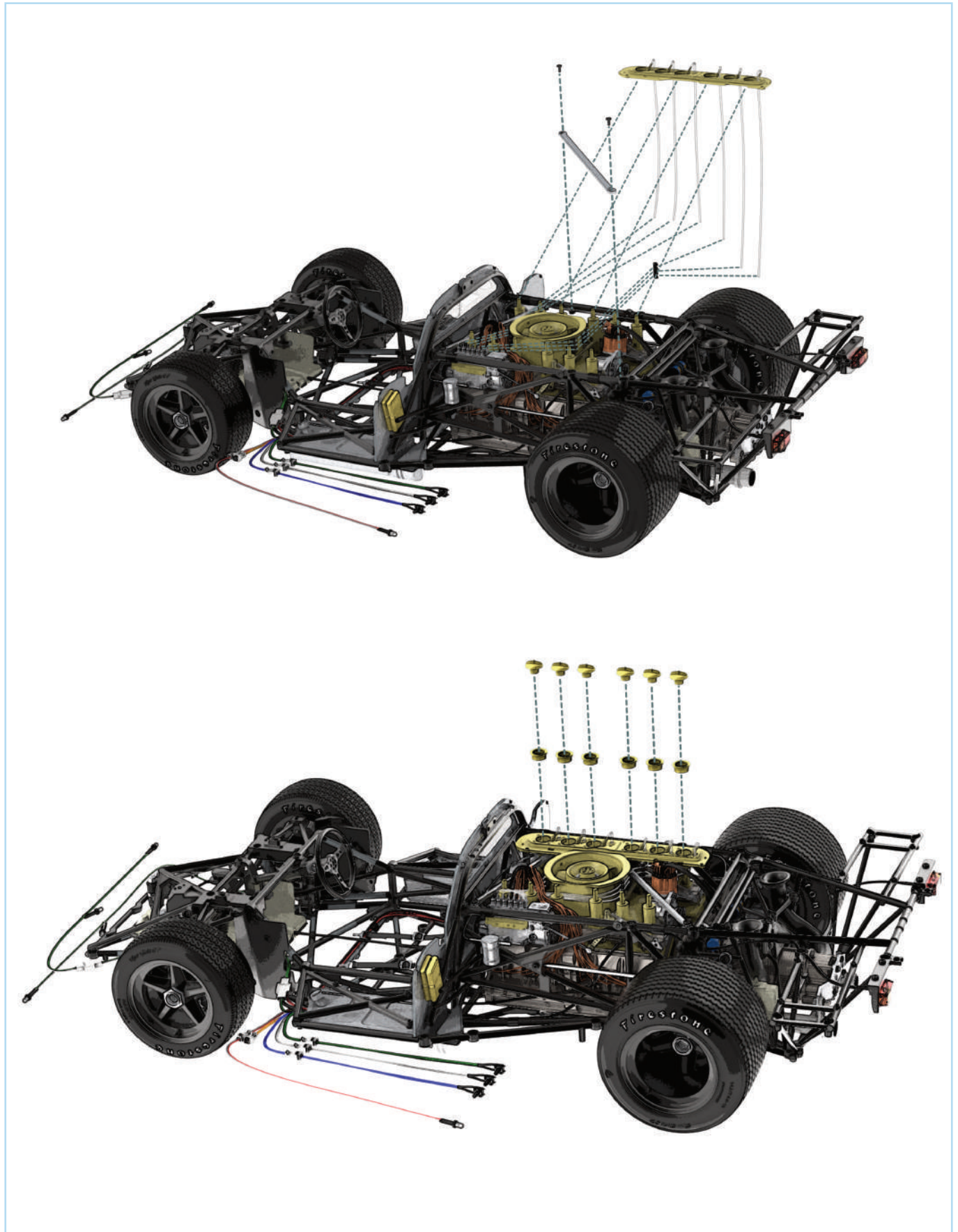

STAGE 57: FITTING THE RIGHT VELOCITY STACK PANEL

STEP 1

Detach the six **intake nozzles (57D)** from their sprue using sprue clippers at the point shown by the red arrow.

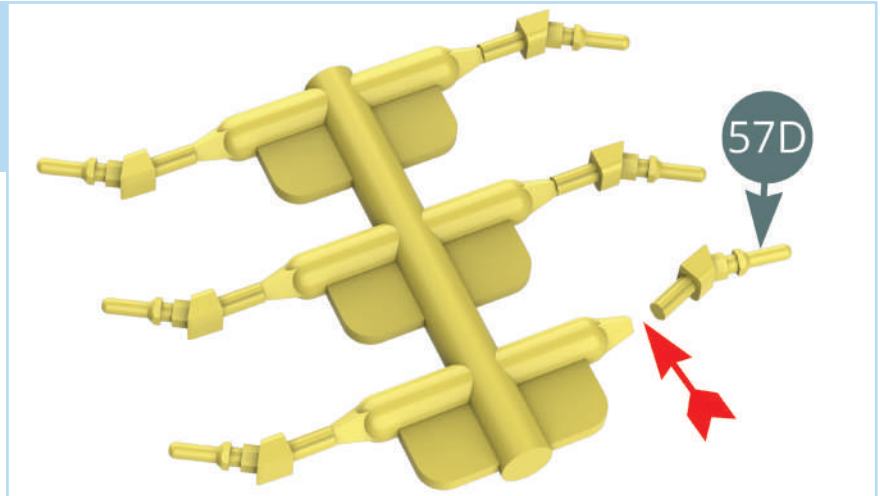

Fit the **intake nozzles (57D)** into the right **velocity stack panel (57A)** as shown.

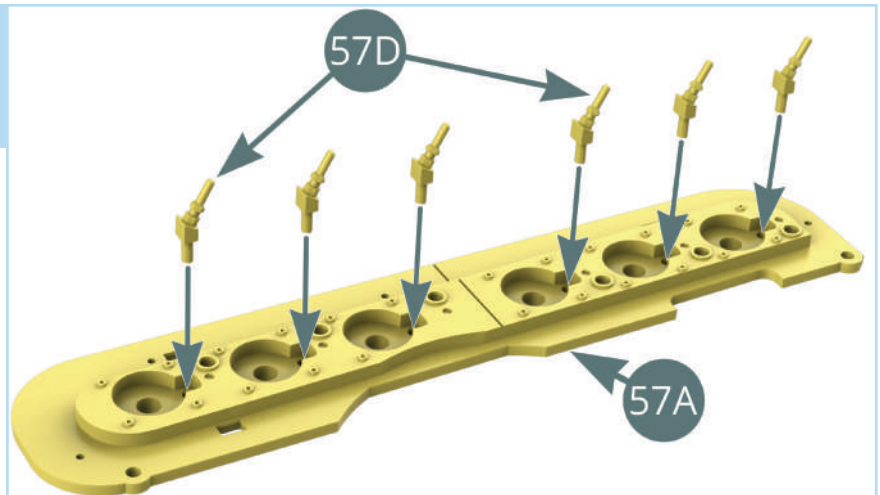

STEP 2

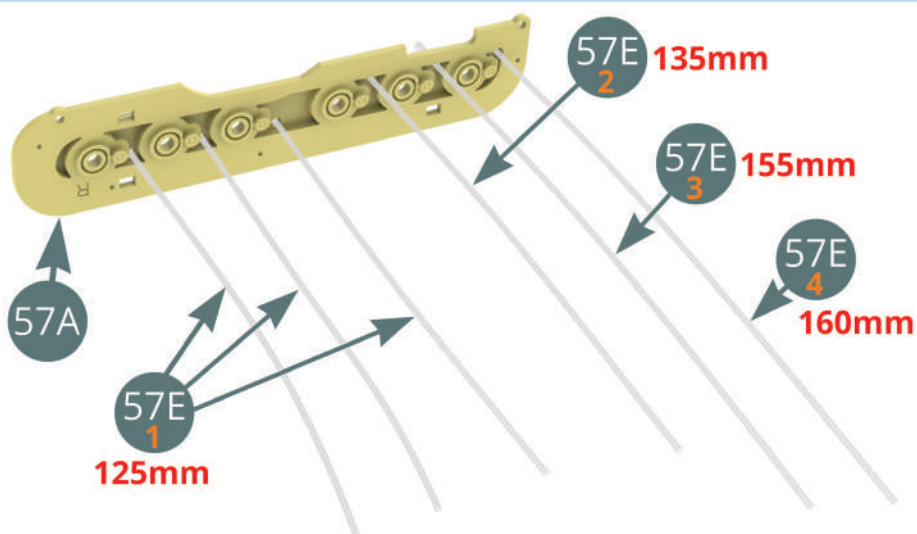

Cut the **fuel line (57E)** into the lengths shown: 125mm (**57E-1**) (x3), 135mm (**57E-2**) (x1), 155mm (**57E-3**) (x1), and 160mm (**57E-4**) (x1). Pass them through the panel as shown.

STAGE 57: FITTING THE RIGHT VELOCITY STACK PANEL

Connect the ends of the **fuel lines (57E)** passed through the panel to the ends of the **intake nozzles (57D)**.

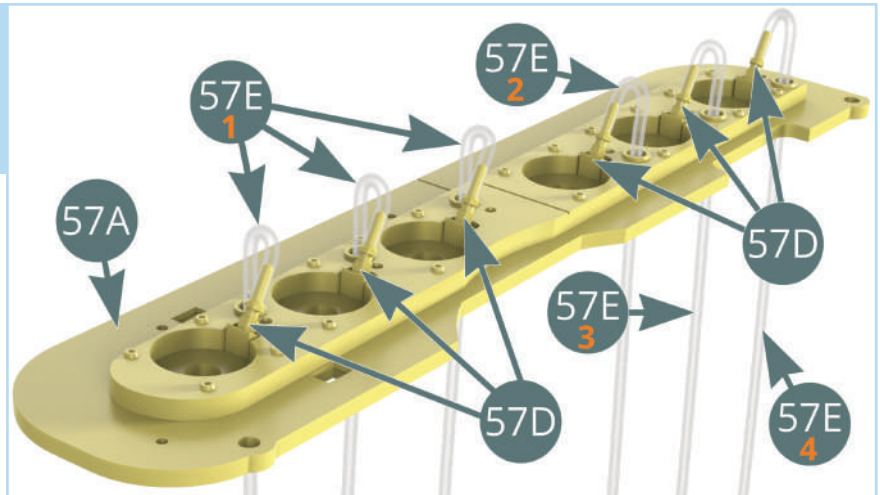

STEP 3

Take the **IM** screws out of the **reinforcement bar (50B)** and remove the bar from the frame. Place them safely to one side.

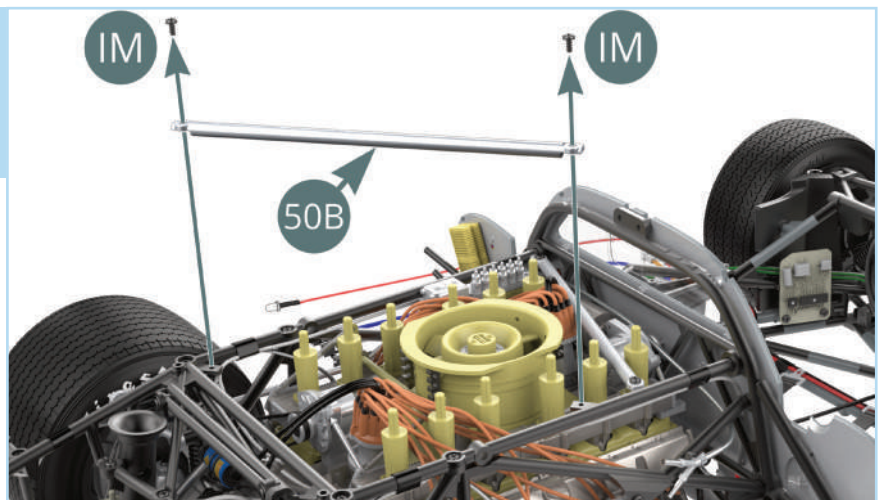

STEP 4

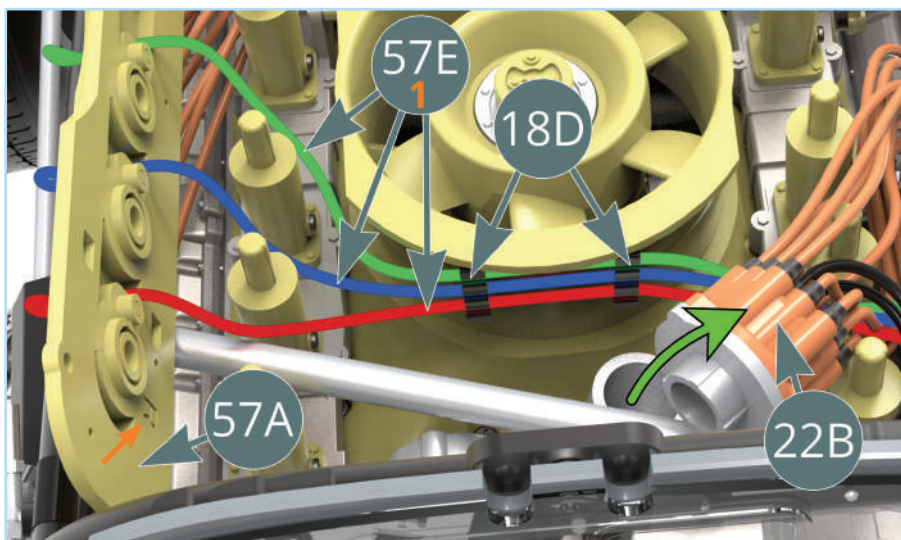

Align the **velocity stack panel (57A)** with the right side of the engine as shown (note the position of the 'R', orange arrow). Guide the **fuel lines (57E-1)** between the orange cables of the **distributor cap (22B)**, then press them into the **fuel line guides (18D)** in the order indicated by the red, blue and green highlight. You may wish to remove the distributor cap, as shown by the green arrow.

STAGE 57: FITTING THE RIGHT VELOCITY STACK PANEL

Replace the **distributor cap (22B)** if it was removed in the previous step. Plug the ends of the **fuel lines (57E-1)** into the **injector nozzles (12L)** as indicated by the red, blue and green highlight.

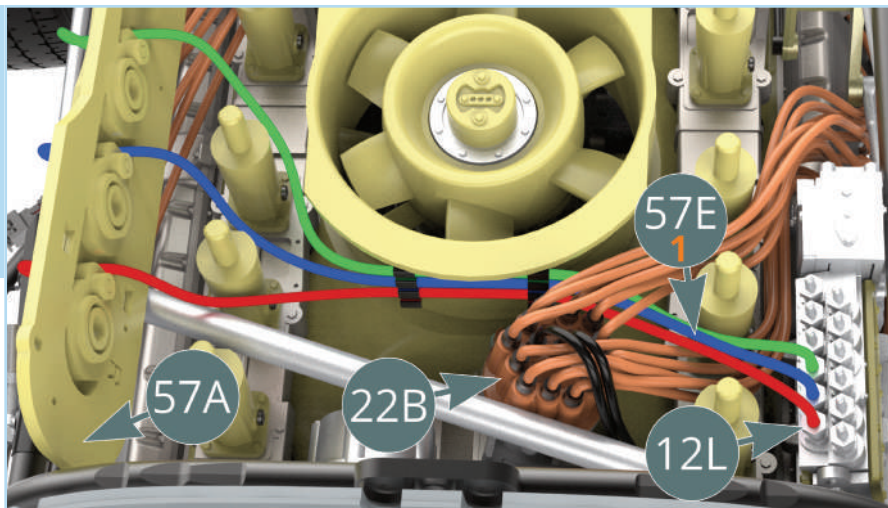

On the other end of the engine, connect the three **fuel lines (57E-2, 57E-3 and 57E-4)** using the **fuel line guides (57F and 18D)** then guide them between the orange cables as before and connect them to the **injector nozzles (12L)**.

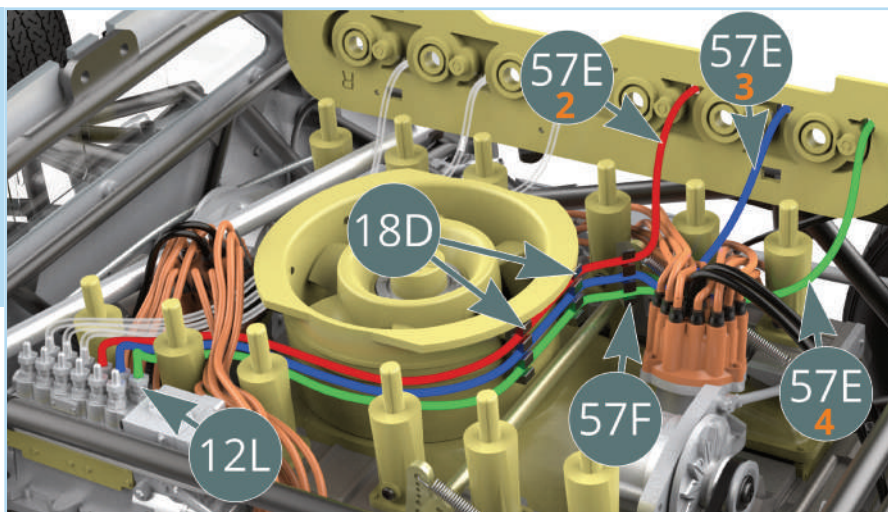

STEP 5

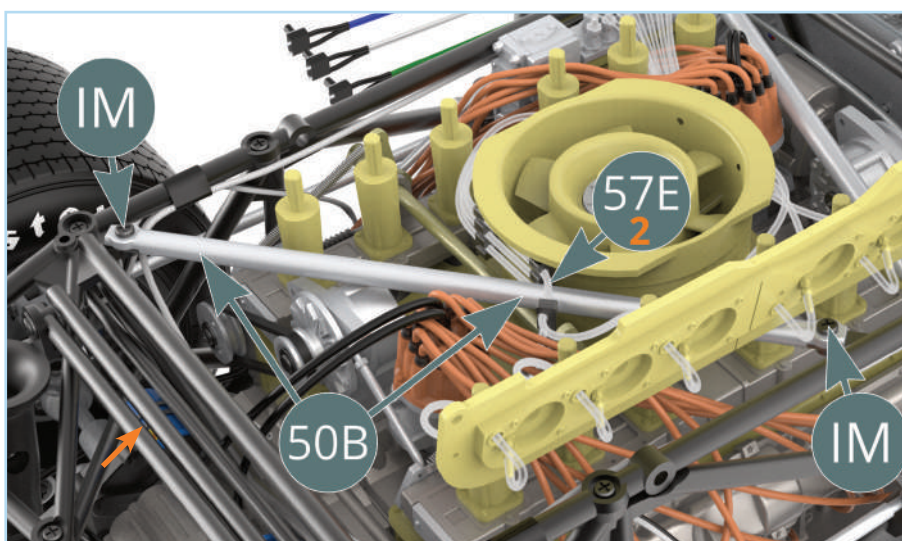

Replace the **reinforcement bar (50B)** in position, ensuring to guide it underneath the top **fuel line (57E-2)**. Fix using the **IM screws** that were removed in step 3.

STAGE 57: FITTING THE RIGHT VELOCITY STACK PANEL

Check that the fuel lines and orange cables are located between the **velocity stacks (16D)** as shown by the red arrows, then fit the **velocity stack panel (57A)** over the pins as shown by the blue arrows.

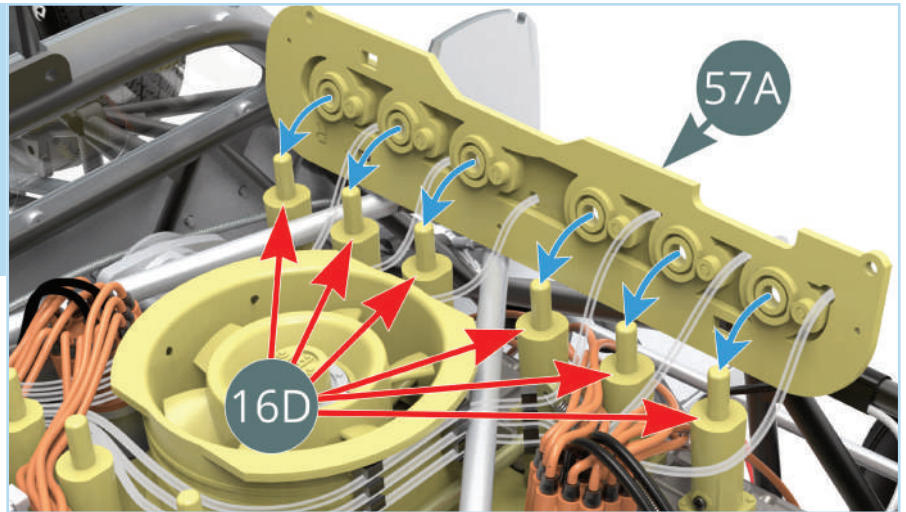

STEP 6

Place the six **velocity stack covers (57C)** over the pins of the **velocity stacks (16D)** which are protruding through the **velocity stack panel (57A)**.

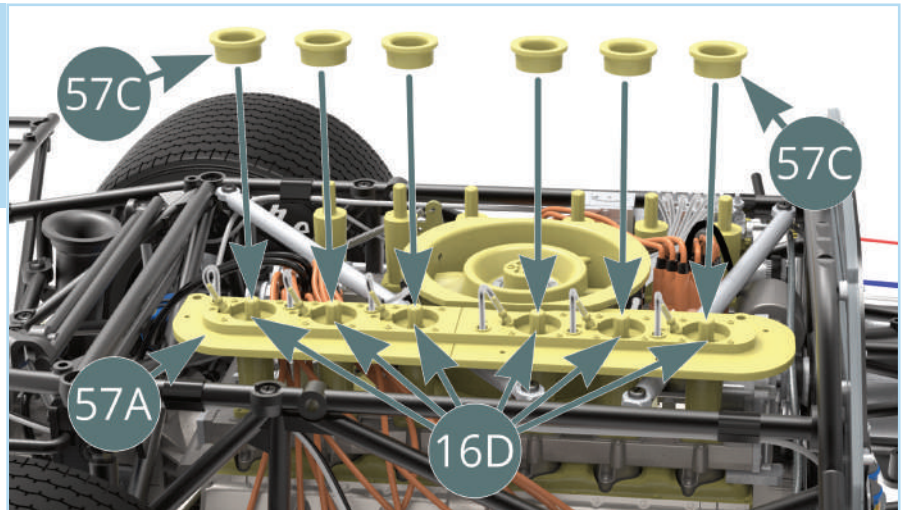

Fit the six **velocity stack necks (57B)** into the **velocity stack covers (57C)**, onto the pins of the **velocity stacks (16D)**.

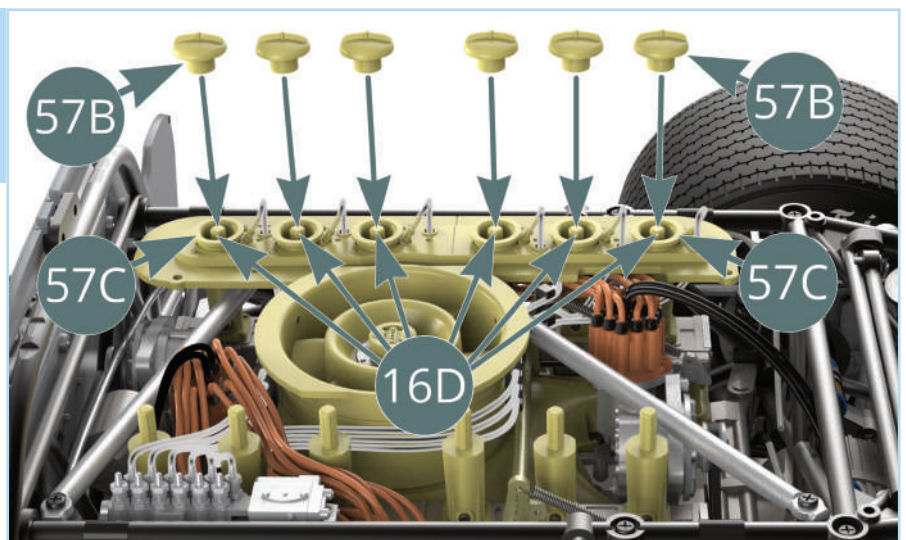

STAGE 57: FITTING THE RIGHT VELOCITY STACK PANEL

STAGE COMPLETE

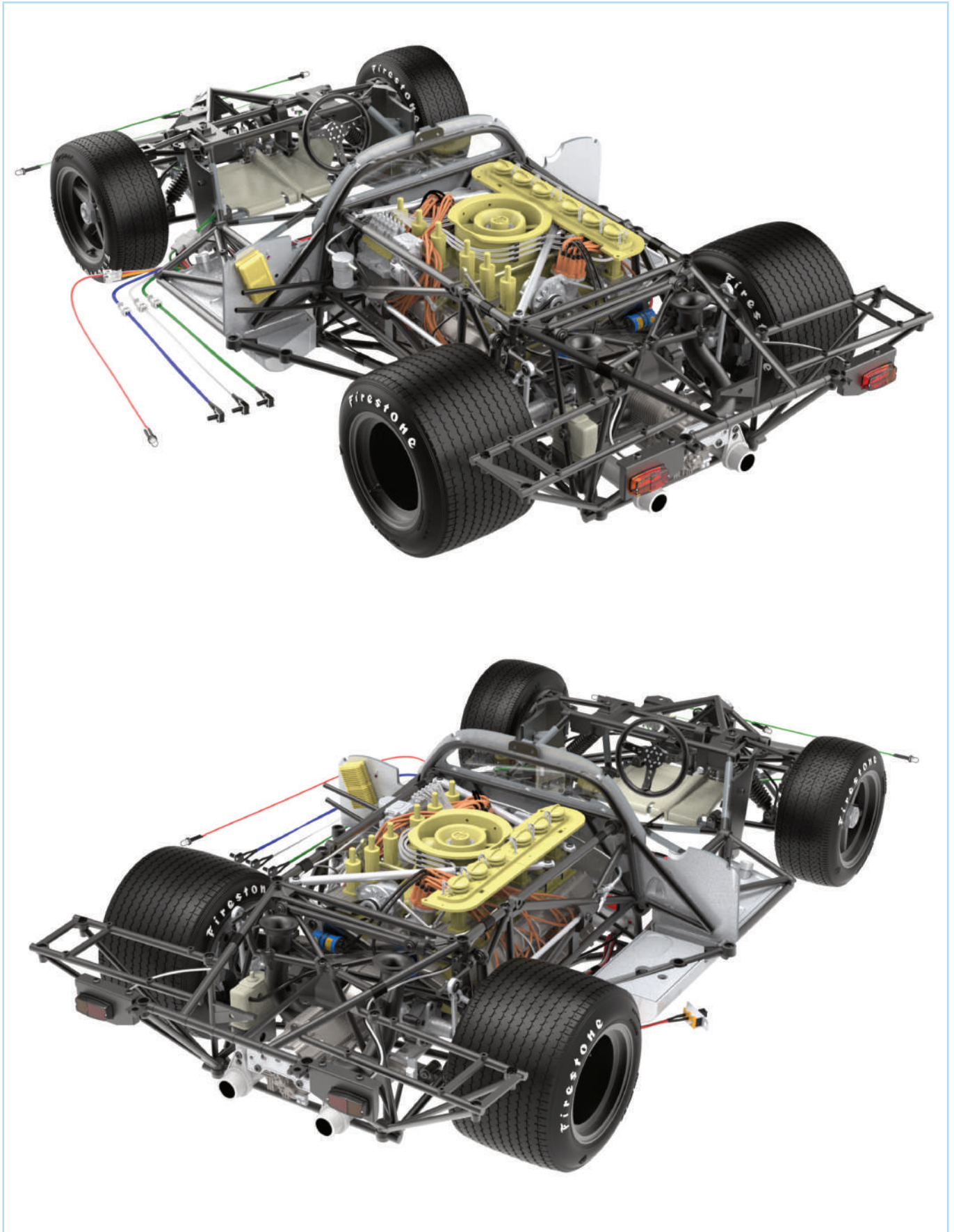

STAGE 58: FITTING THE LEFT VELOCITY STACK PANEL

58A Velocity stack panel (left)

58B Velocity stack cover (x6)

58C Velocity stack neck (x6)

58D Intake nozzle (x6)

58E Fuel line

58F Fuel line guide

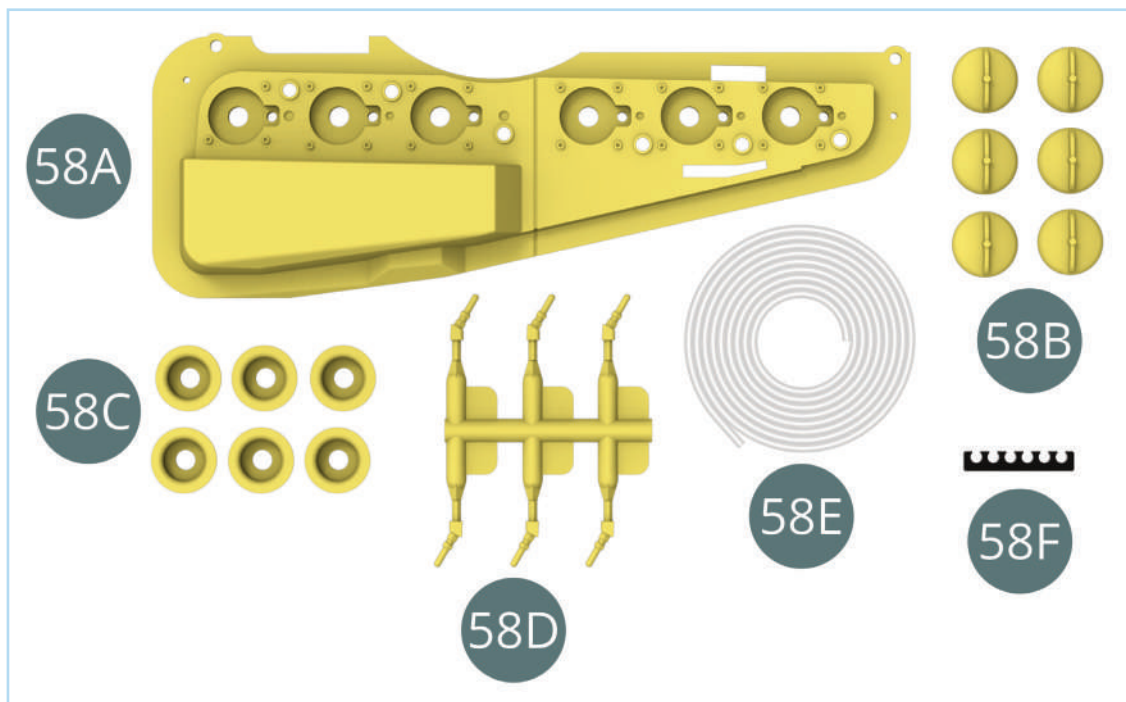

ASSEMBLY DIAGRAM

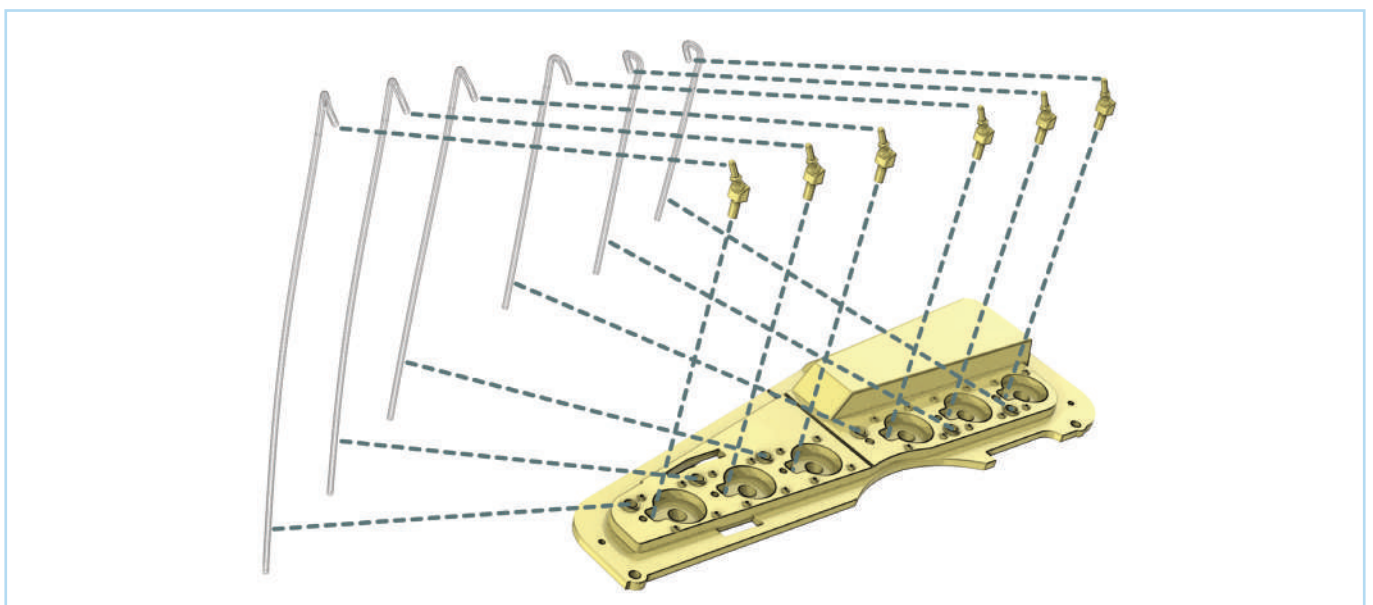

STAGE 58: FITTING THE LEFT VELOCITY STACK PANEL

ASSEMBLY DIAGRAM

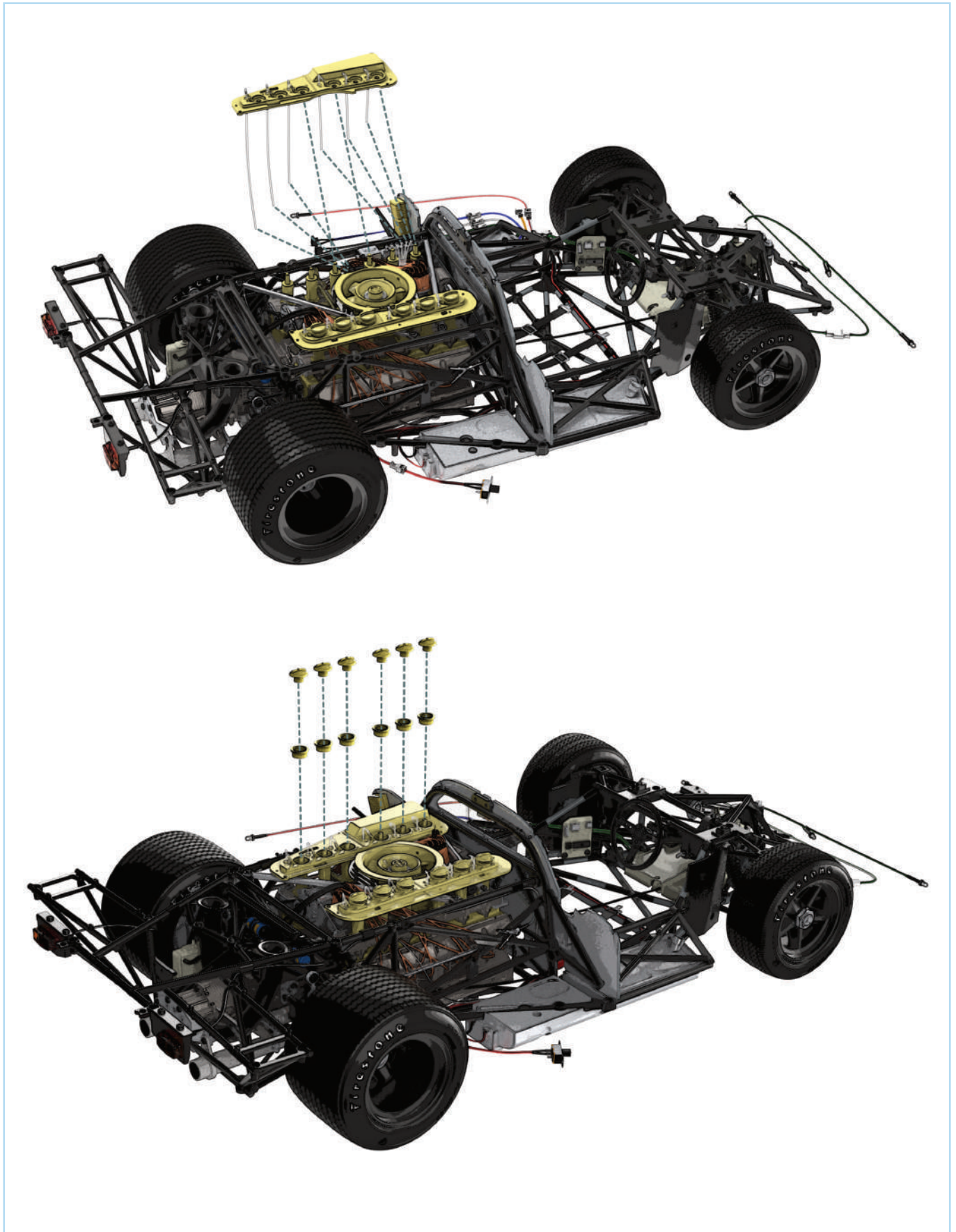

STAGE 58: FITTING THE LEFT VELOCITY STACK PANEL

STEP 1

Detach the six **intake nozzles (58D)** from their sprue using sprue clippers at the point shown by the red arrow.

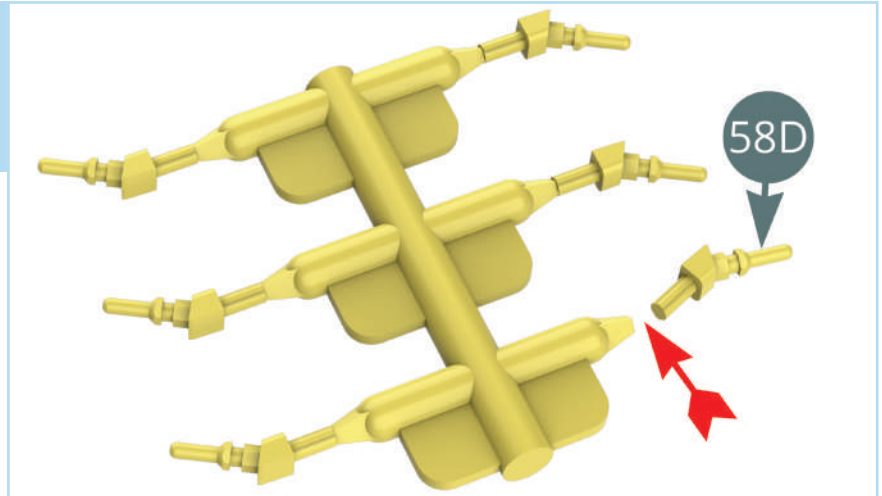

Fit the **intake nozzles (58D)** into the left **velocity stack panel (58A)** as shown.

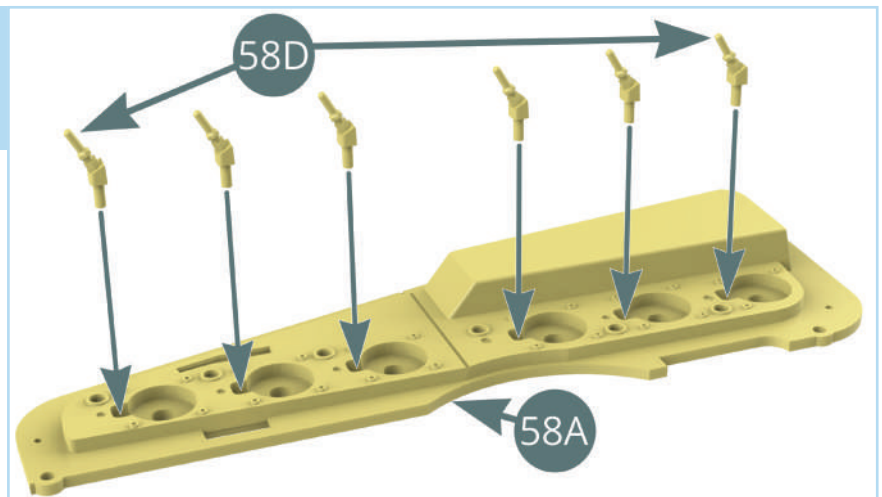

STEP 2

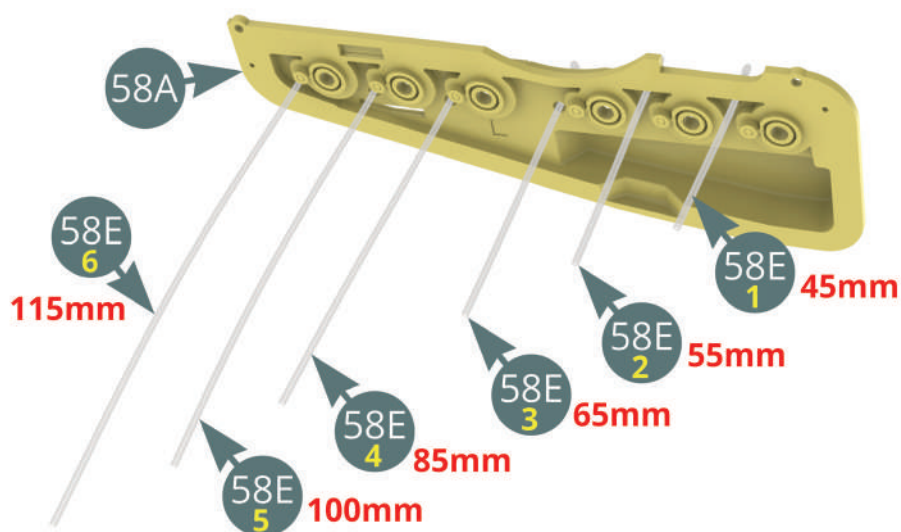

Cut the **fuel line (58E)** into the lengths shown: 45mm (**58E-1**), 55mm (**58E-2**), 65mm (**58E-3**), 85mm (**58E-4**), 100mm (**58E-5**), and 115mm (**58E-6**). Pass them through the panel as shown.

STAGE 58: FITTING THE LEFT VELOCITY STACK PANEL

Connect the ends of the **fuel lines (58E)** passed through the panel to the ends of the **intake nozzles (58D)**.

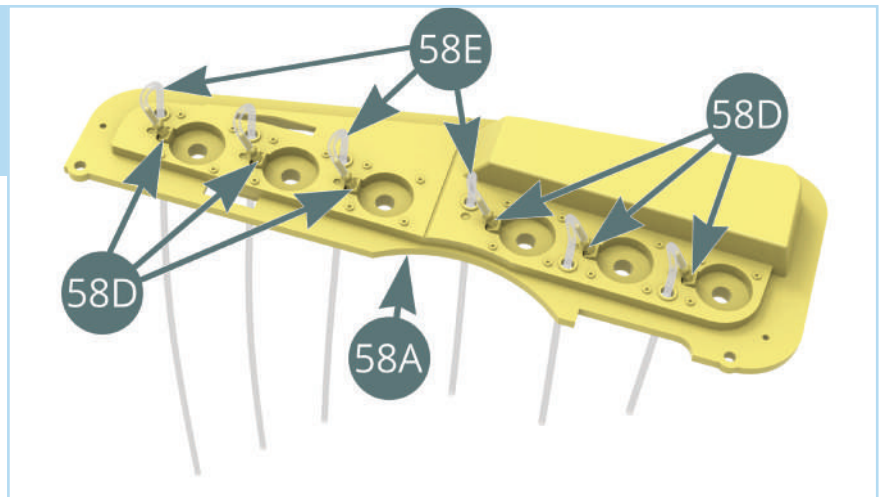

STEP 3

Route the three **fuel lines (57E-2, 57E-3 and 57E-4)** through the **fuel line guide (58F)**. Note the order as indicated by the red, blue and green highlights.

You may find it easier to fit the fuel lines into the guide using a pair of tweezers to carefully press them in.

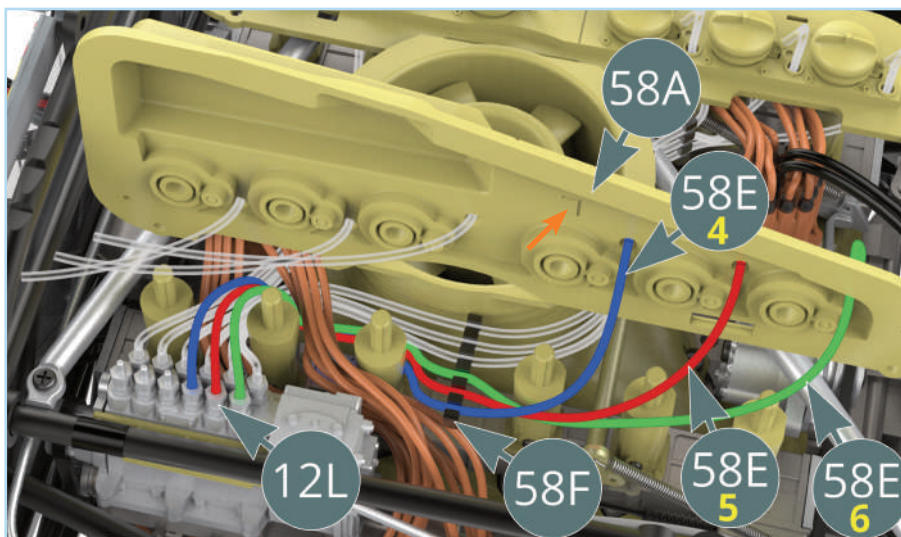
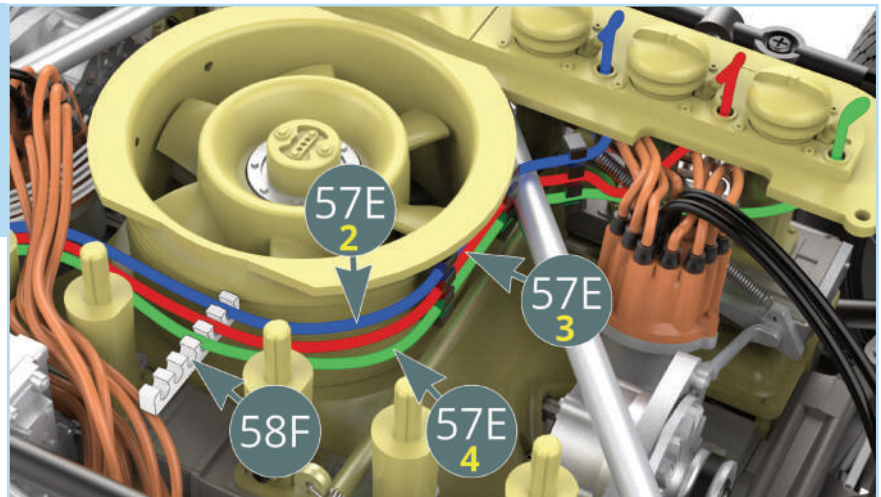

Align the **velocity stack panel (58A)** with the left side of the engine as shown (note the position of the 'L', orange arrow). Press the **fuel lines (58E-4, 58E-5 and 58E-6)** between the orange cables and into **injector nozzles (12L)** as shown. Press the lines into the **fuel line guide (58F)** in the order indicated by the red, blue and green highlight.

STAGE 58: FITTING THE LEFT VELOCITY STACK PANEL

STEP 4

Fit the ends of the **fuel lines (58E-1, 58E-2 and 58E-3)** into the injector nozzles, as shown by the highlights.

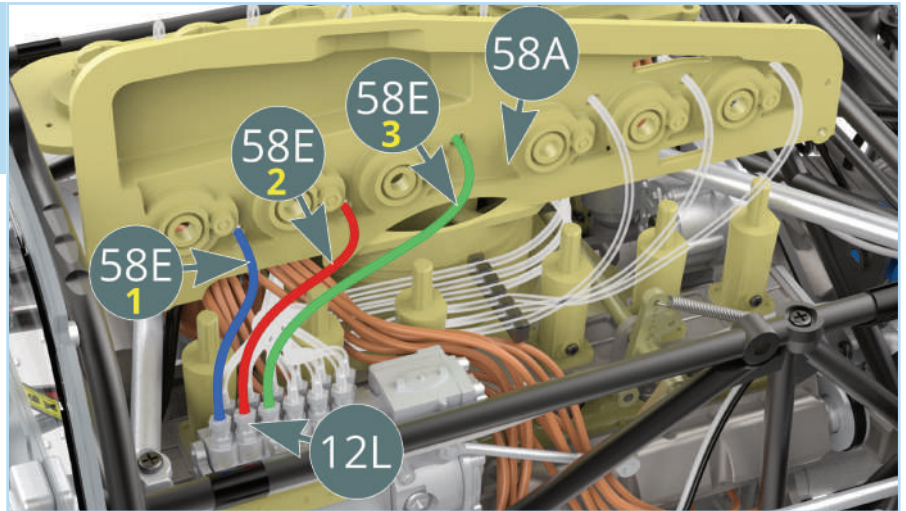

Check that the fuel lines and orange cables are located between the **velocity stacks (15D)** as shown by the red arrows, then fit the **velocity stack panel (58A)** over the pins as shown by the blue arrows.

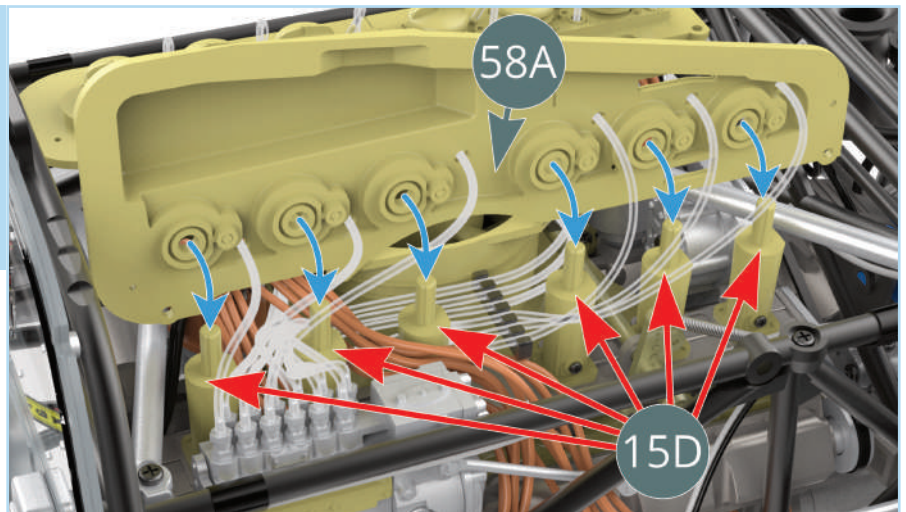

STEP 5

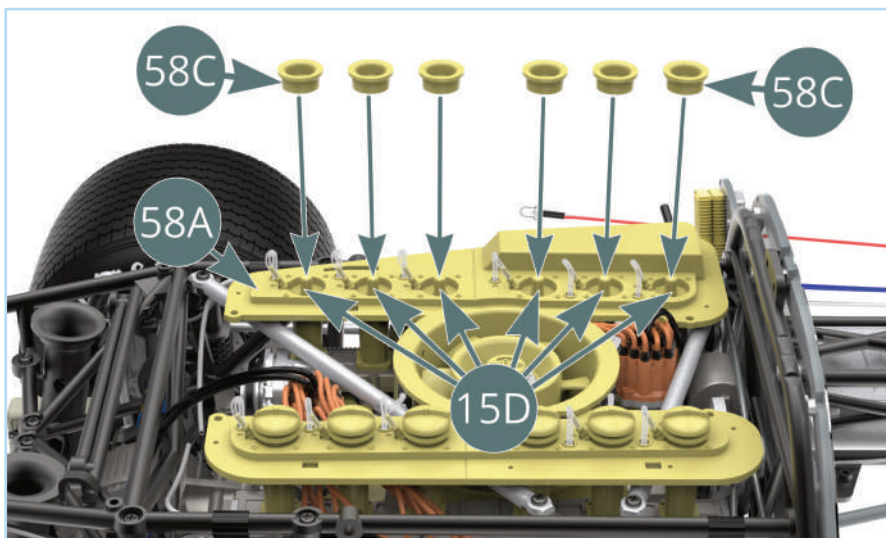

Place the six **velocity stack covers (58C)** over the pins of the **velocity stacks (15D)** which are protruding through the **velocity stack panel (58A)**.

STAGE 58: FITTING THE LEFT VELOCITY STACK PANEL

Fit the six **velocity stack necks (58B)** into the **velocity stack covers (58C)**, onto the pins of the **velocity stacks (15D)**.

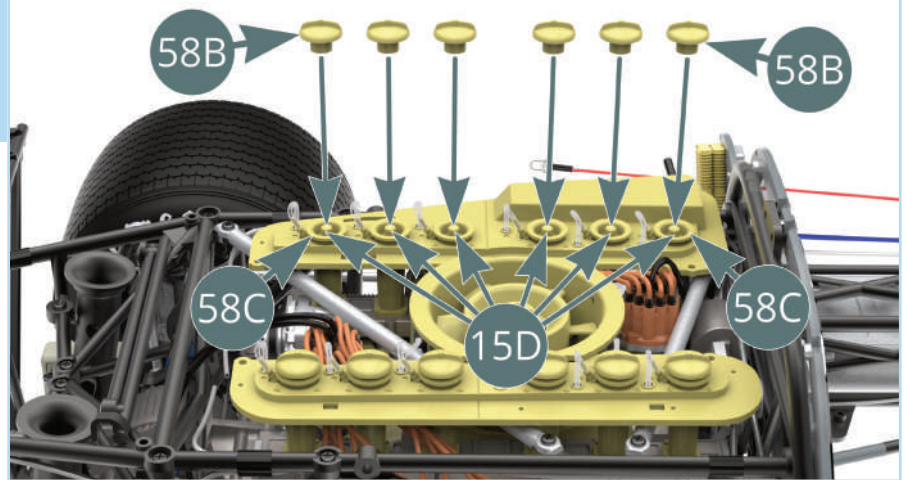

STAGE COMPLETE

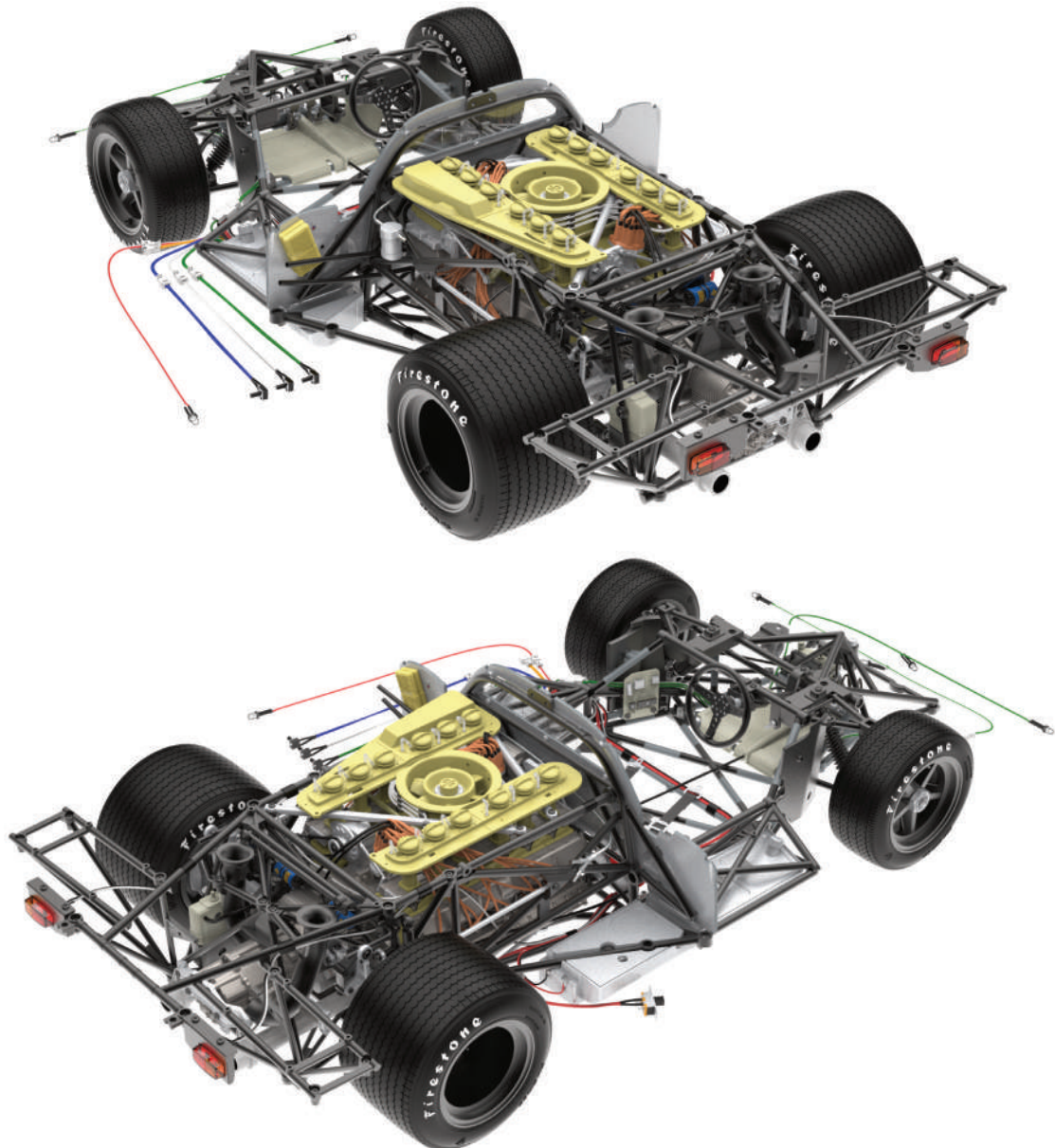

STAGE 59: FIXING COVERS ONTO THE ENGINE AND THE VELOCITY STACKS

59A Velocity stack cover (left)

LP Screws 1.2 x 3.5 mm (x13)

59B Velocity stack cover (right)

59C Engine cover

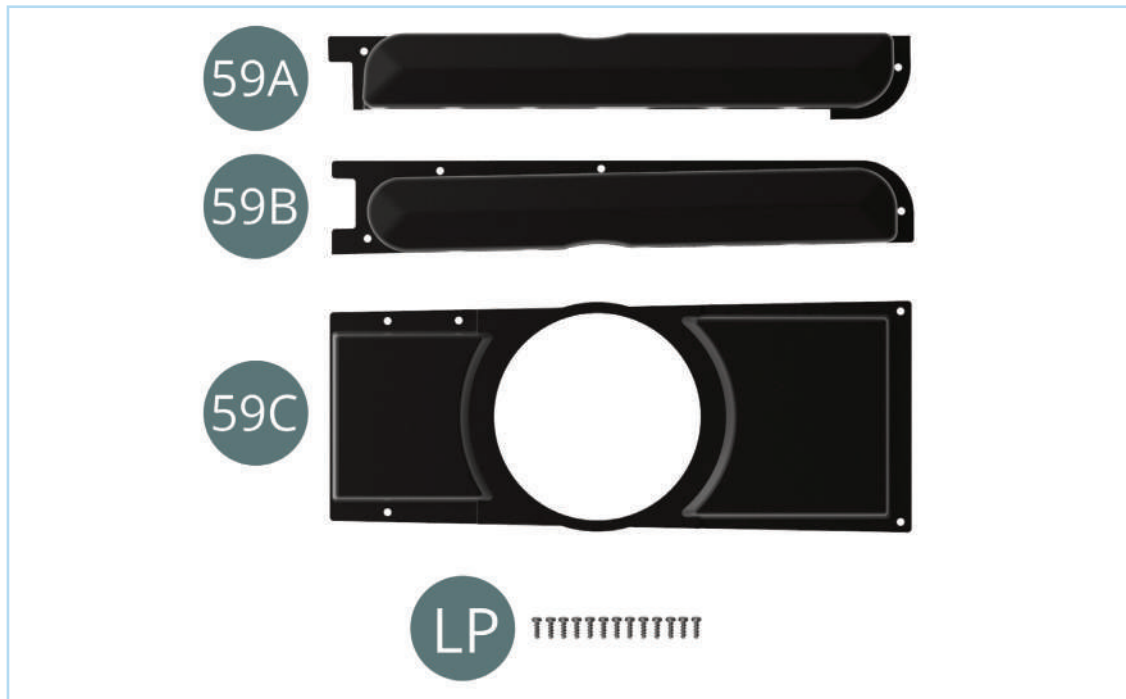

ASSEMBLY DIAGRAM

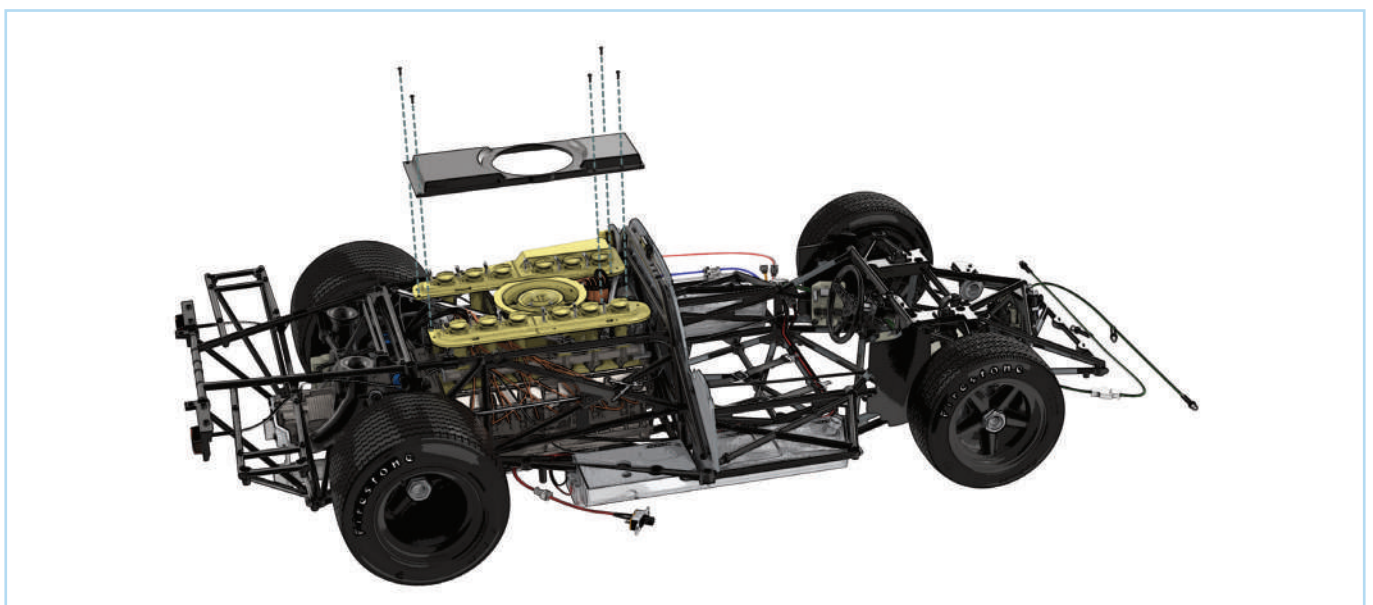

STAGE 59: FIXING COVERS ONTO THE ENGINE AND THE VELOCITY STACKS

ASSEMBLY DIAGRAM

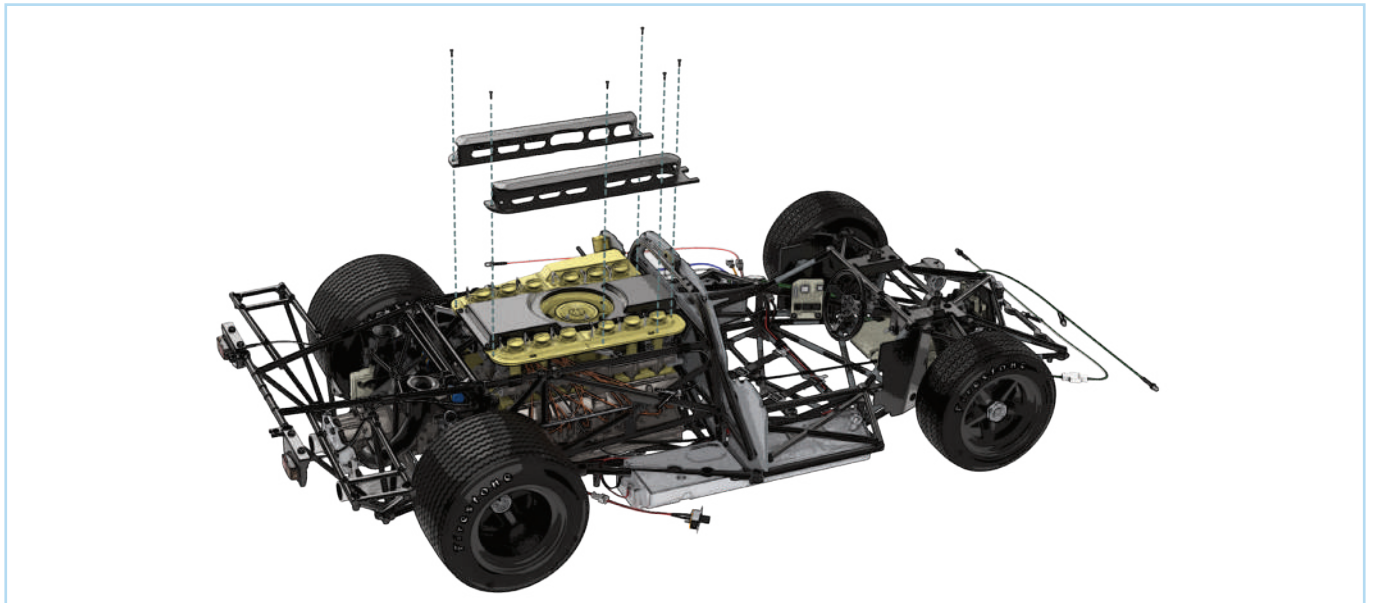

STEP 1

Fit the **engine cover (59C)** over the left **(58A)** and right **(57A)** velocity stack panels.



Secure the cover using five **LP** screws as shown.

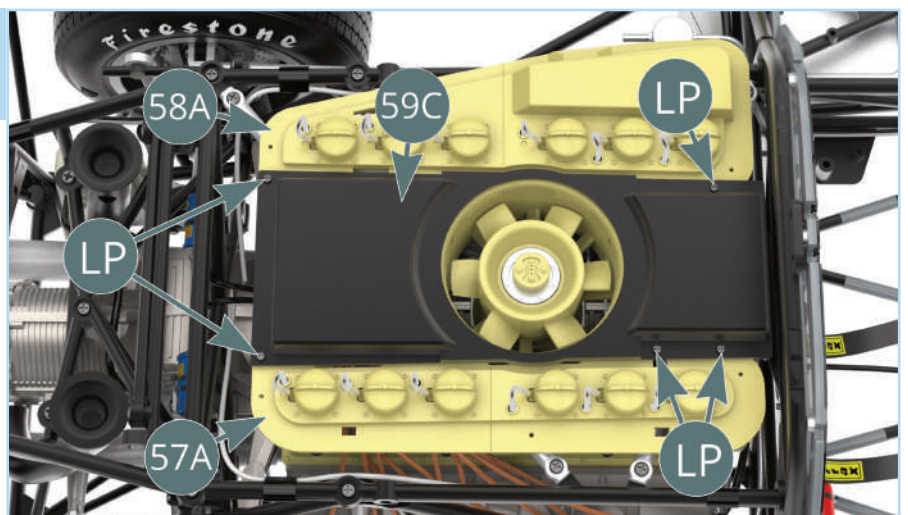

STAGE 59: FIXING COVERS ONTO THE ENGINE AND THE VELOCITY STACKS

STEP 2

Fit the left (marked 'L') **velocity stack cover (59A)** onto the left **velocity stack panel (58A)** and secure using two **LP** screws.

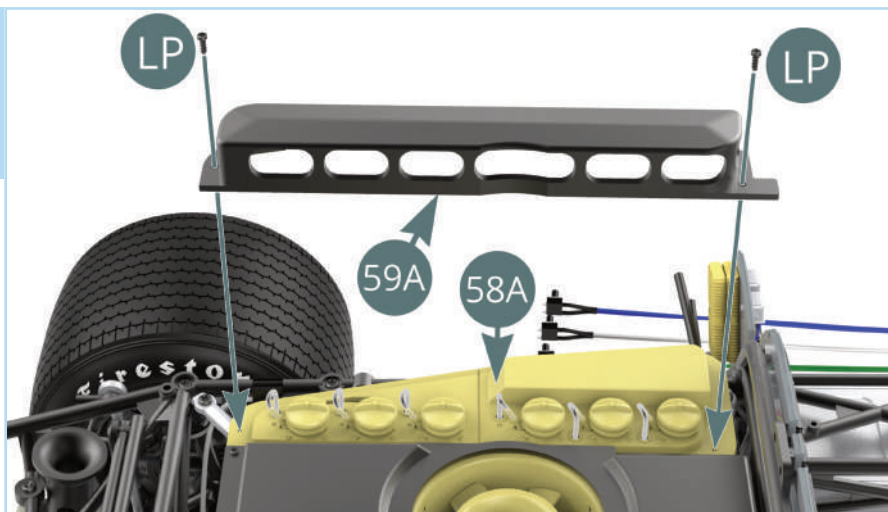

Fit the right (marked 'R') **velocity stack cover (59B)** onto the right **velocity stack panel (57A)** and secure using four **LP** screws.

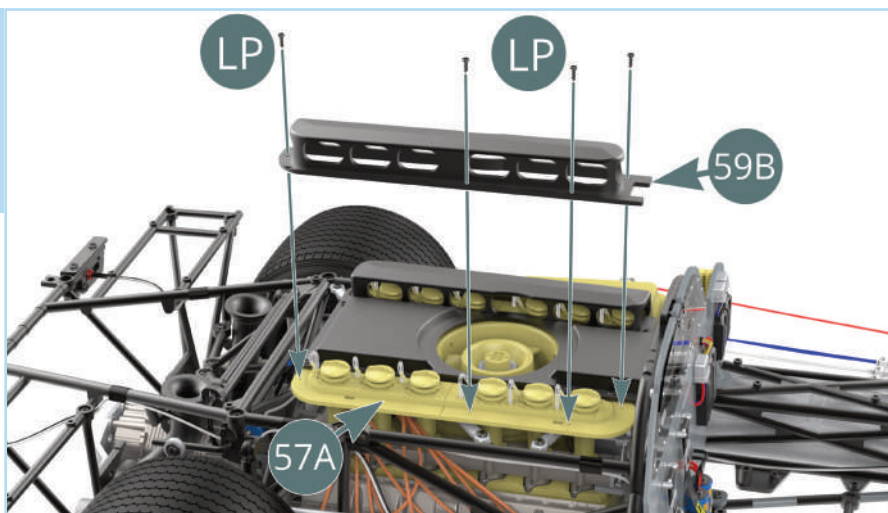

The covers have been mounted onto the engine.

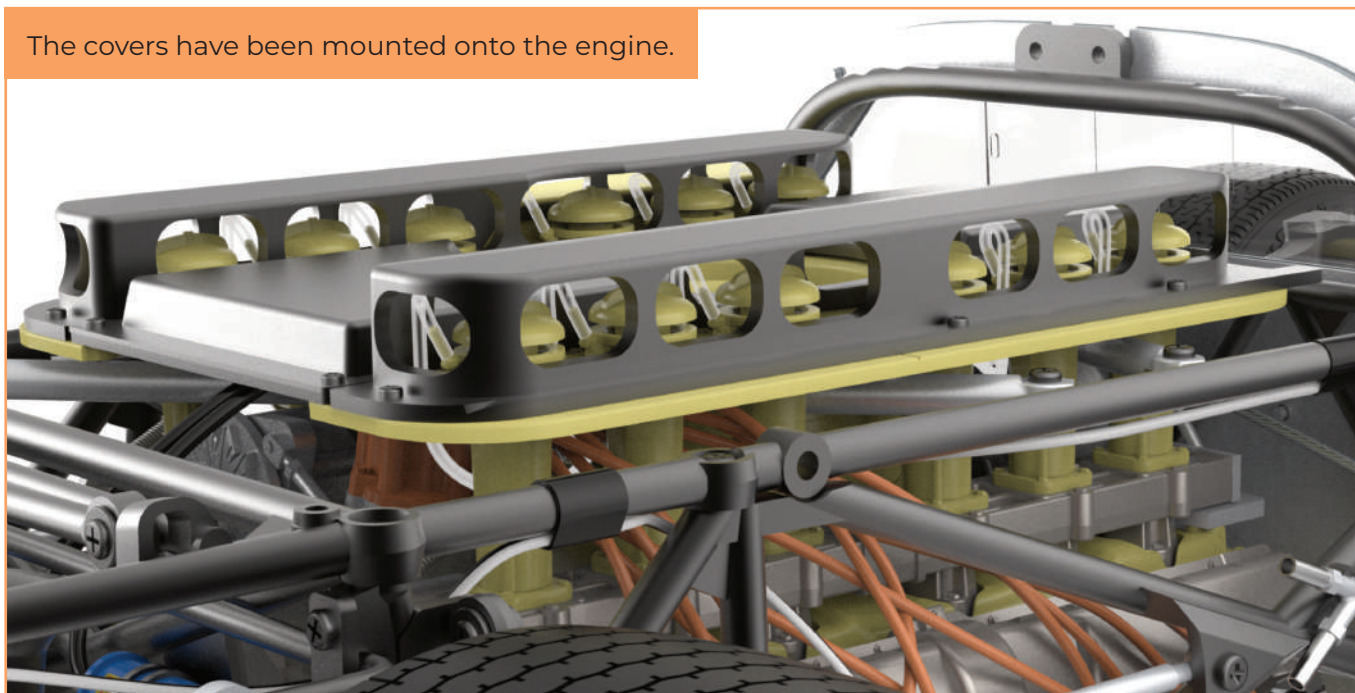

STAGE 59: FIXING COVERS ONTO THE ENGINE AND THE VELOCITY STACKS

STAGE COMPLETE

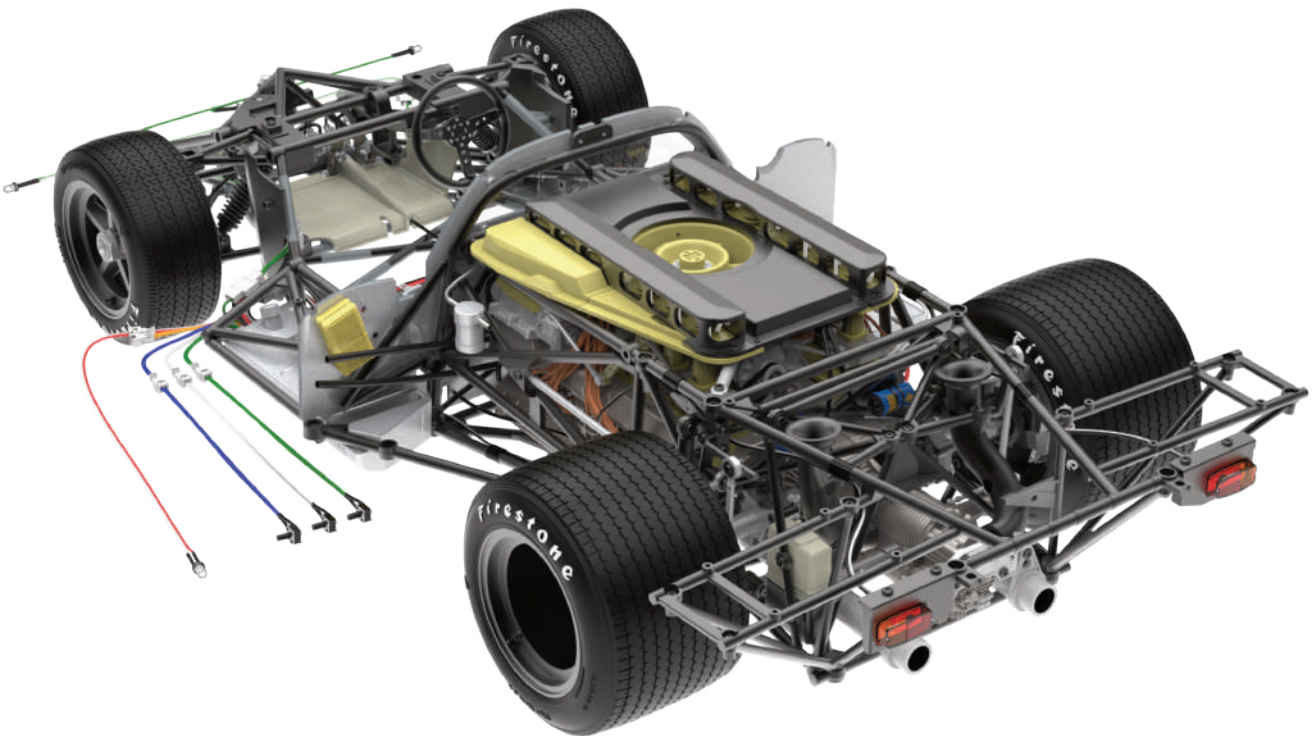
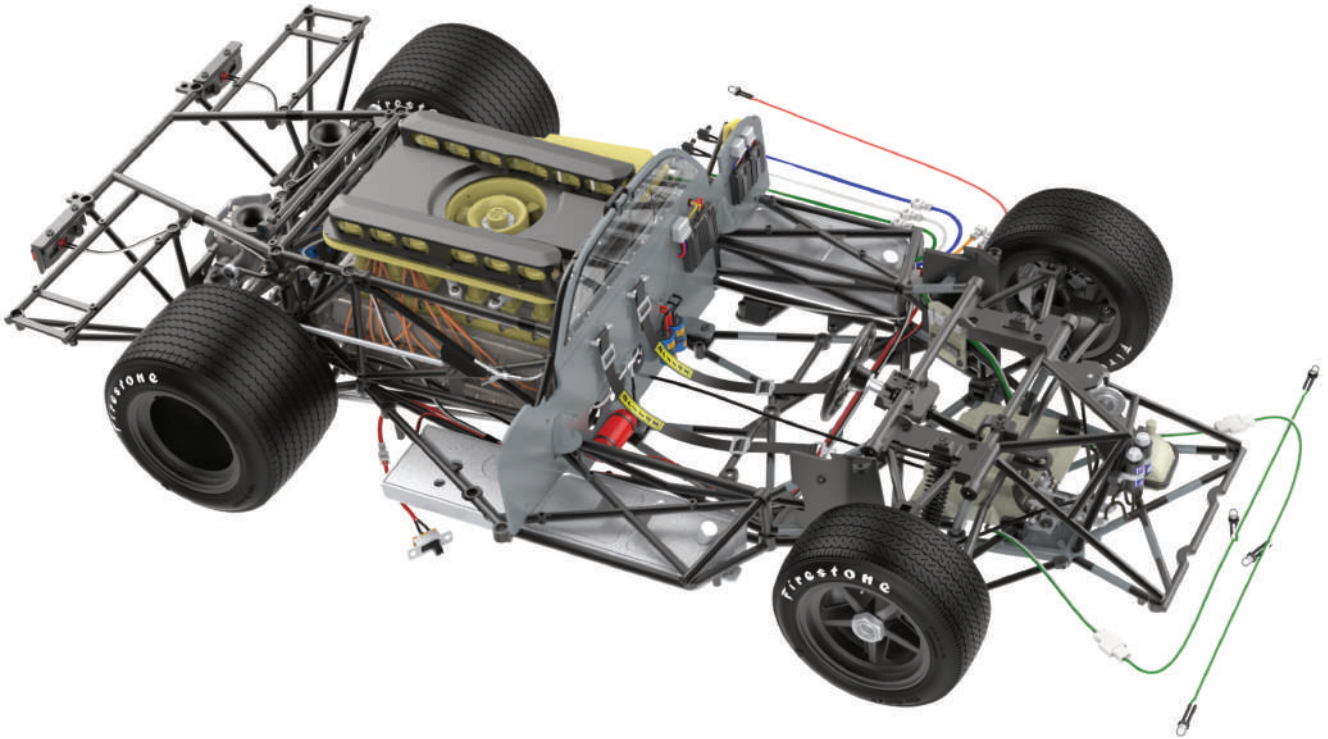

STAGE 60: ATTACHING THE BATTERY AND THE GEAR LEVER

- 60A** Battery
- 60B** Battery cover
- 60C** Battery terminal (x2)
- 60D** Battery cable (long)
- 60E** Battery cable (short)
- 60F** Battery strap
- 60G** Battery holder
- 60H** Gear lever with gear rod
- 60I** Gearbox rod
- LP** Screws 1.2 x 3.5 mm (x3)

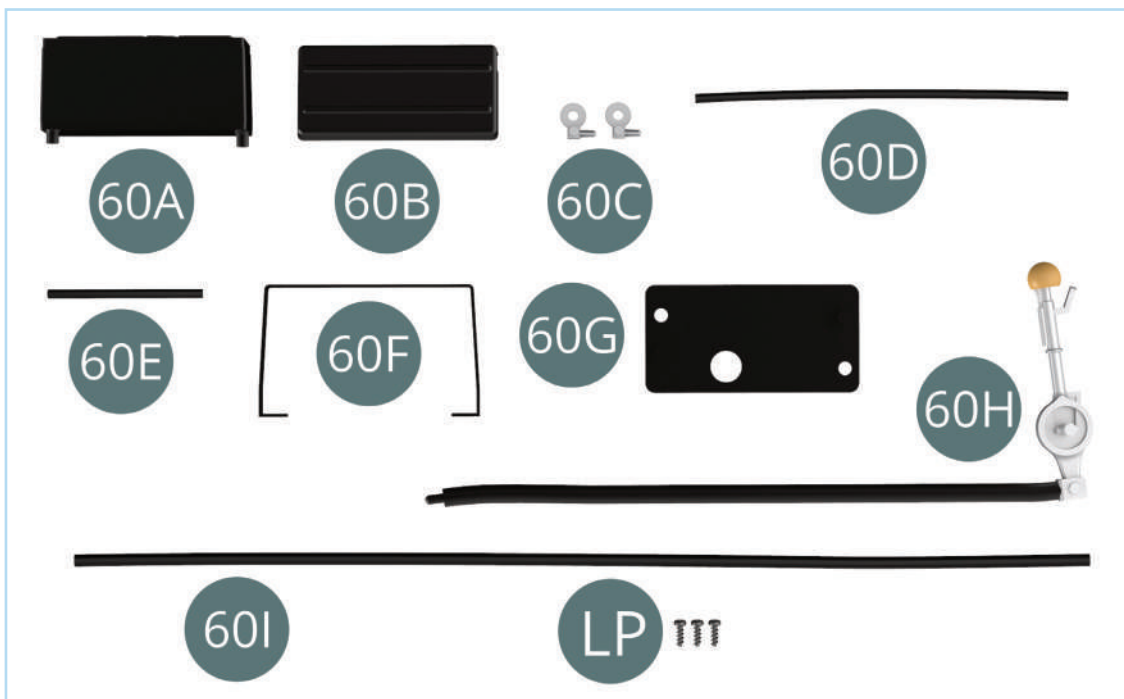

ASSEMBLY DIAGRAM

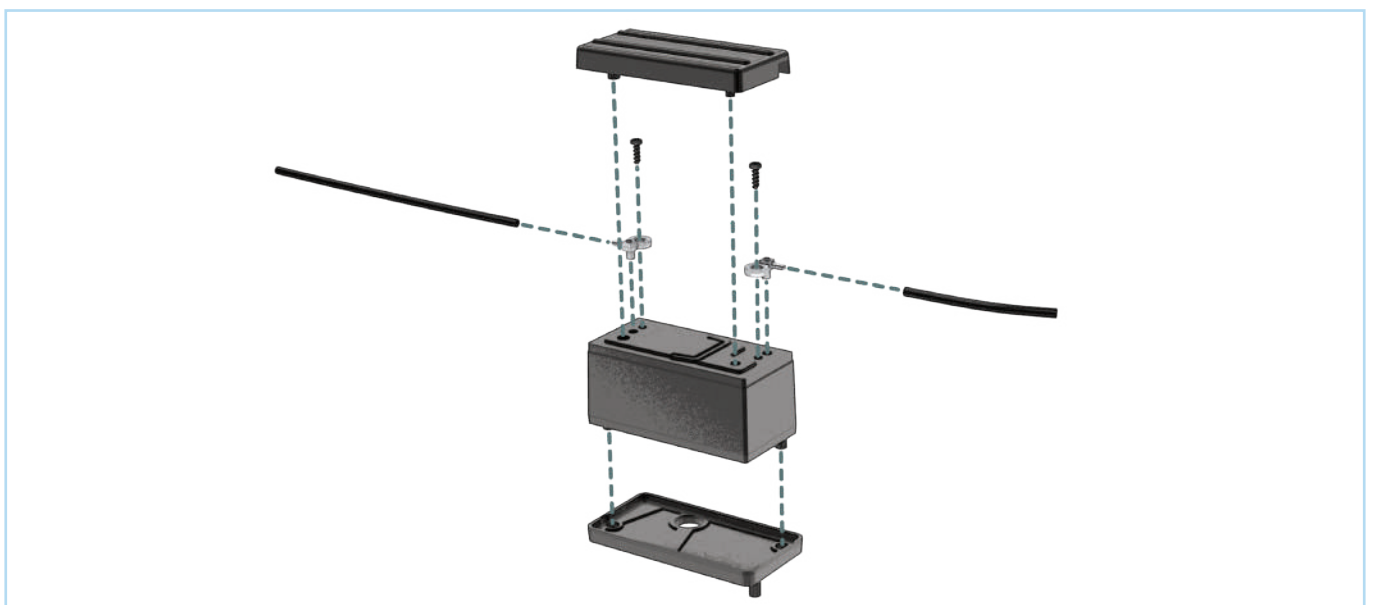

STAGE 60: ATTACHING THE BATTERY AND THE GEAR LEVER

ASSEMBLY DIAGRAM

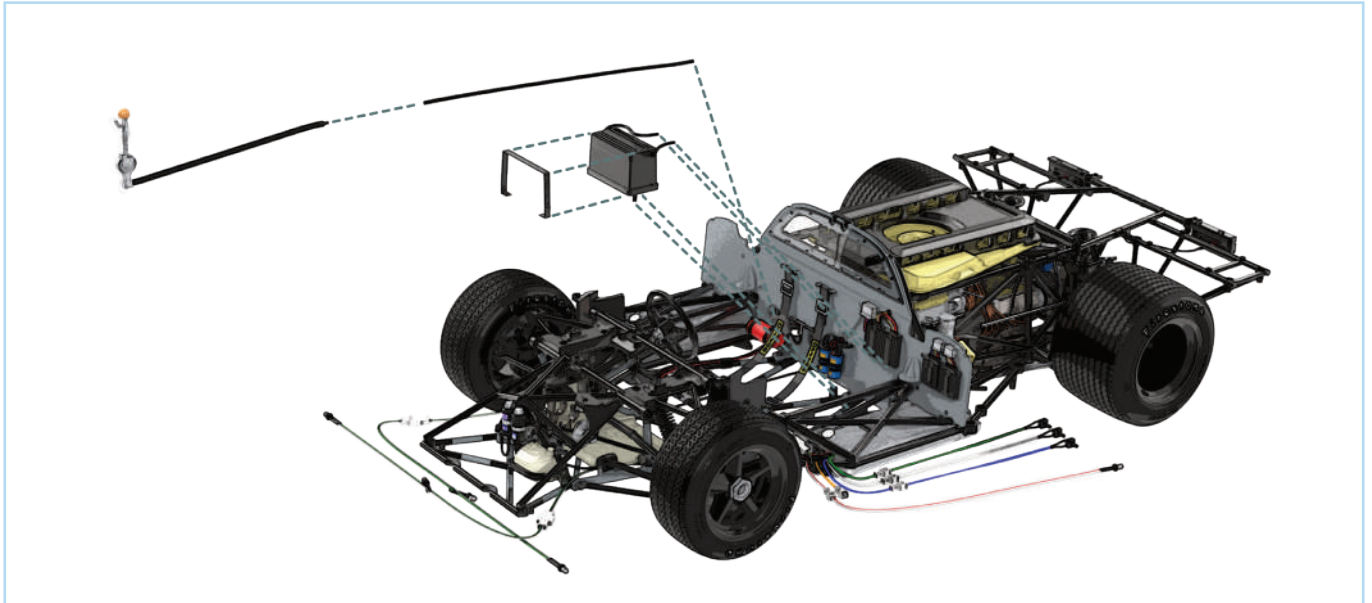

STEP 1

First fit the long and short **battery cables (60D and 60E)** over the **battery terminals (60C)**. Once in place, press the terminals into the **battery (60A)** and secure using two **LP screws**. Fit the battery into the **battery holder (60G)** by pushing the two pins into the corresponding holes.

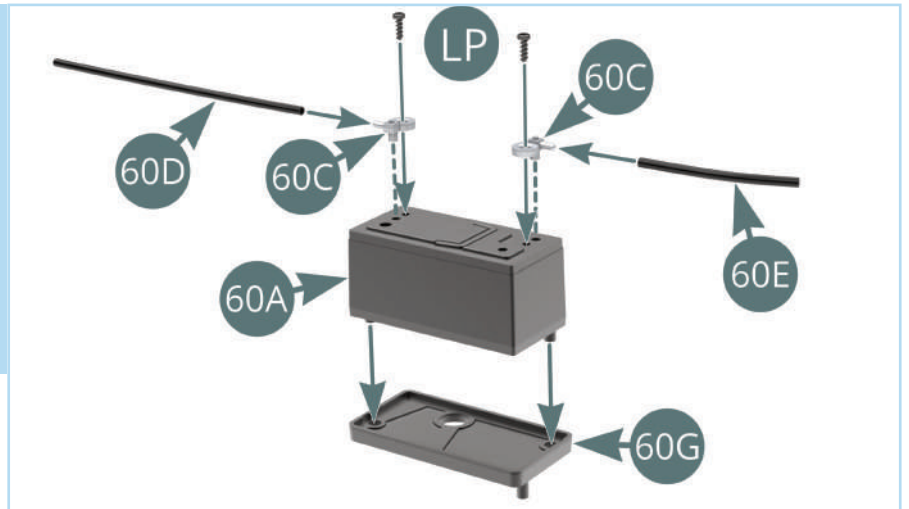

Fit the **battery cover (60B)** on top of the **battery (60A)**.

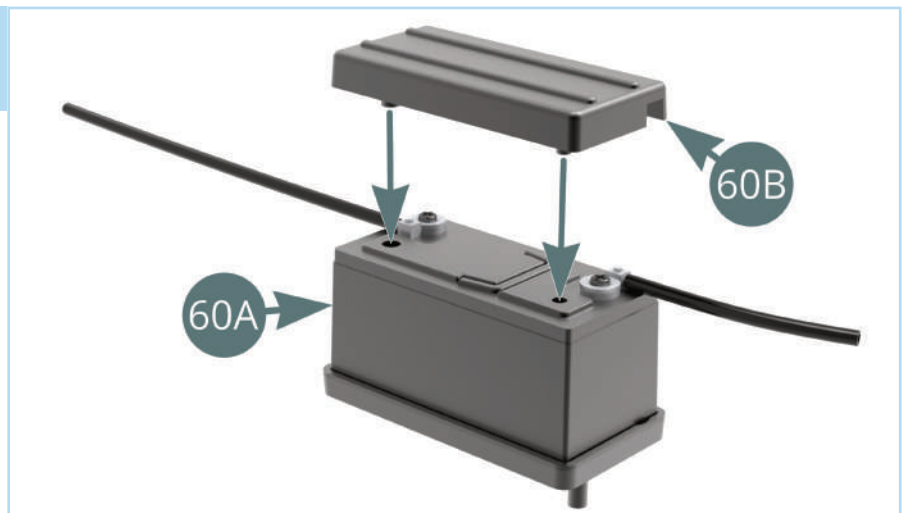

STAGE 60: ATTACHING THE BATTERY AND THE GEAR LEVER

STEP 2

Carefully stretch open the ends of the **battery strap (60F)** and position it over the **battery (60A)**. The angled ends should sit underneath the **battery holder (60G)**.

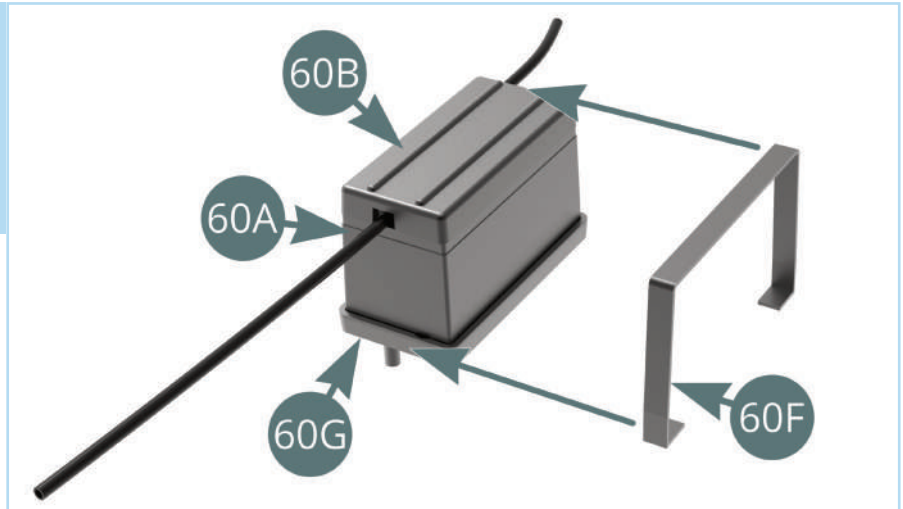

The battery is now ready to be installed on the chassis.

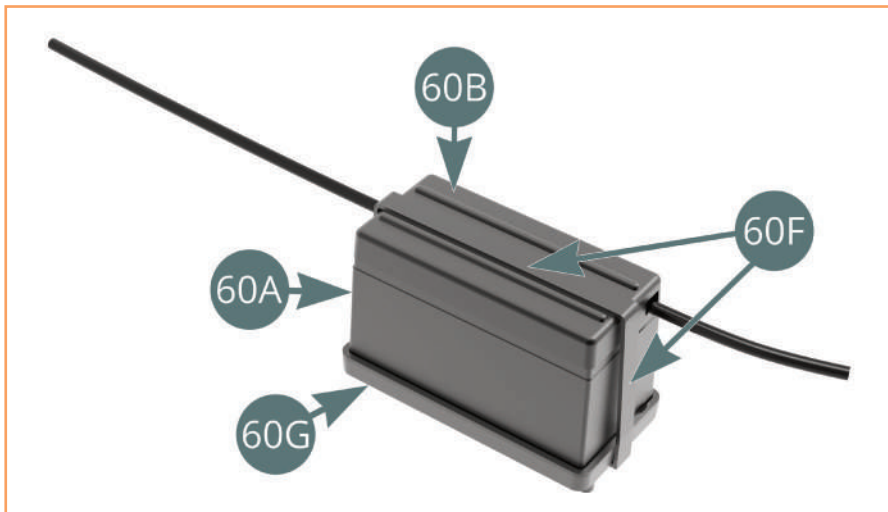

STEP 3

Press the pins of the **battery holder (60G)** into the two holes in the **chassis (25A)**, in front of the cabin bulkhead.

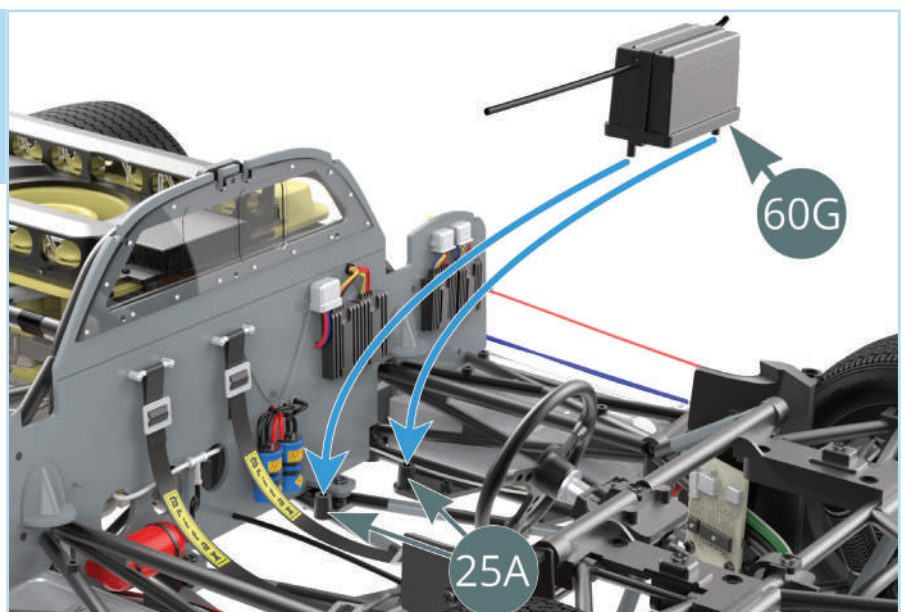

STAGE 60: ATTACHING THE BATTERY AND THE GEAR LEVER

Connect the long **battery cable (60D)** to the pin located underneath the **ignition box (56K)**, in the middle. The short **battery cable (60E)** connects to the other pin located under the box as shown.

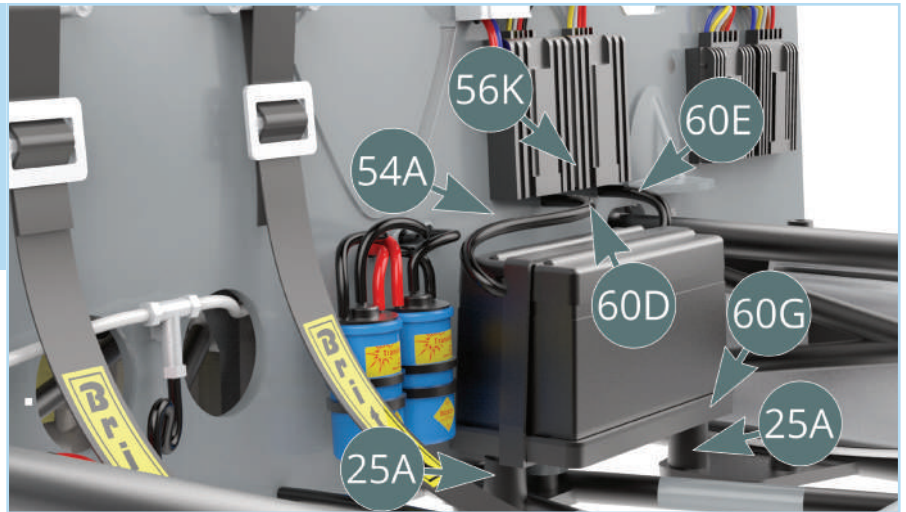

STEP 4

Connect the **gear lever (60H)** to the **gearbox rod (60I)**, then pass the rod through the opening in the **cabin bulkhead (54A)**.

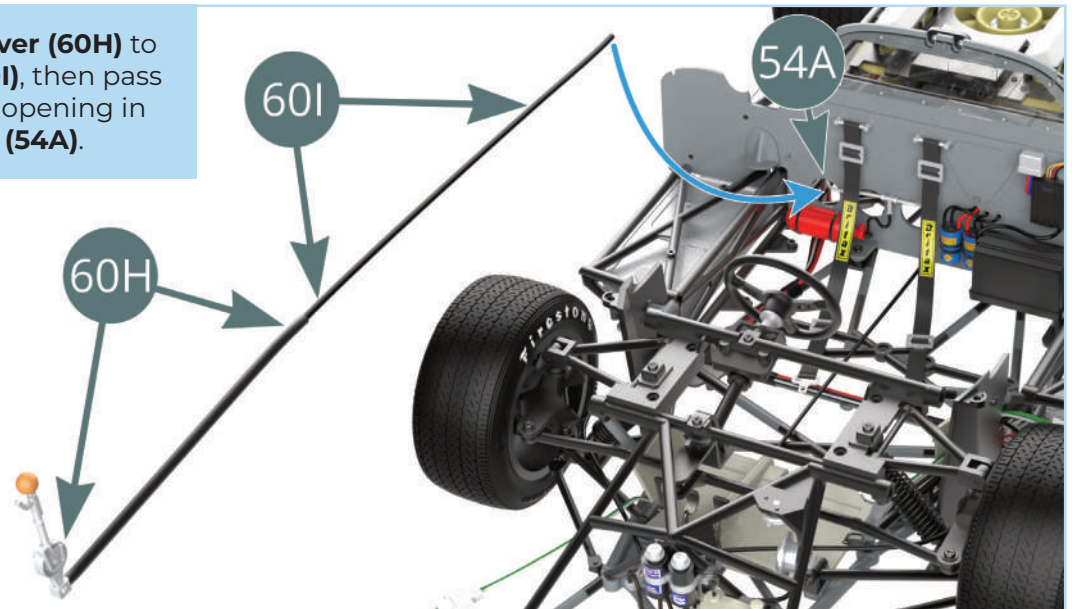

Guide the **gearbox rod (60I)**, highlighted red, along the side of the engine towards the rear of the model. The shaft of the **gear lever (60H)**, highlighted blue, should be positioned inside the opening.

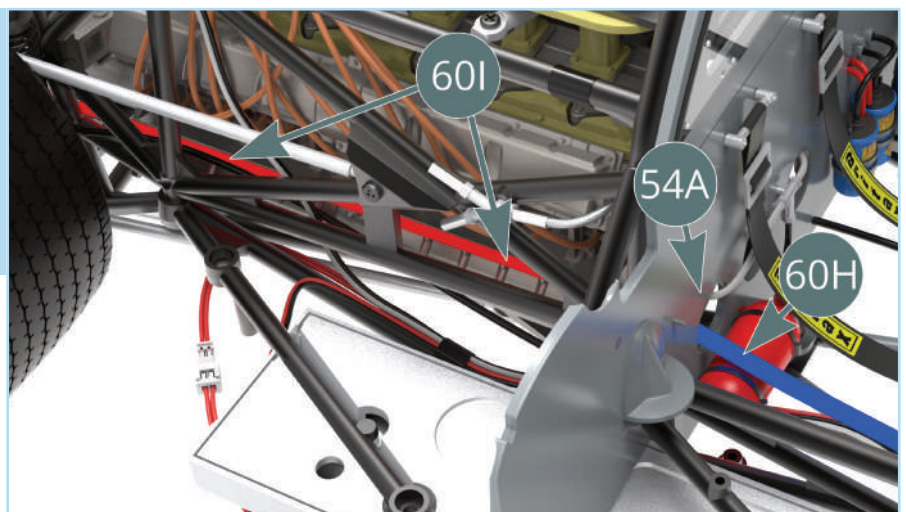

STAGE 60: ATTACHING THE BATTERY AND THE GEAR LEVER

STEP 5

Connect the end of the **gearbox rod (60I)** to the pin on the **gearbox support (53E)**. We recommend using tweezers and grasping the end of the rod from underneath, as the openings in the chassis allow easier access from below.

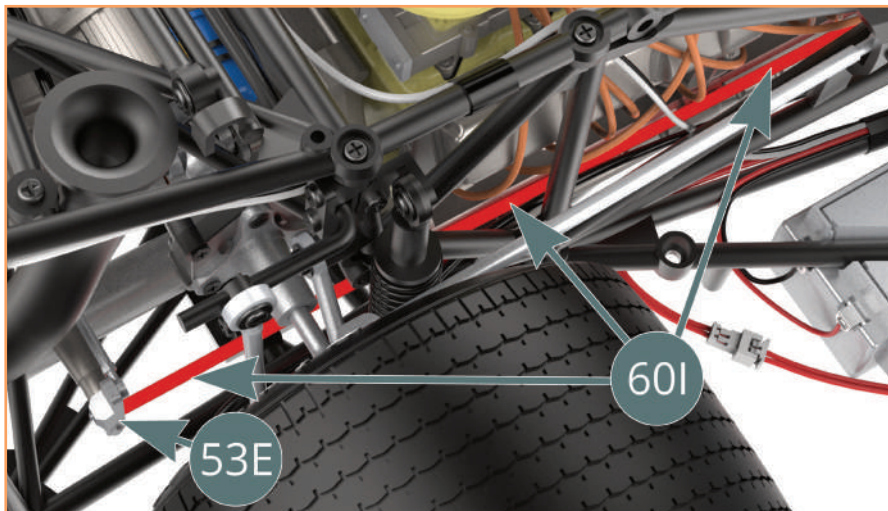
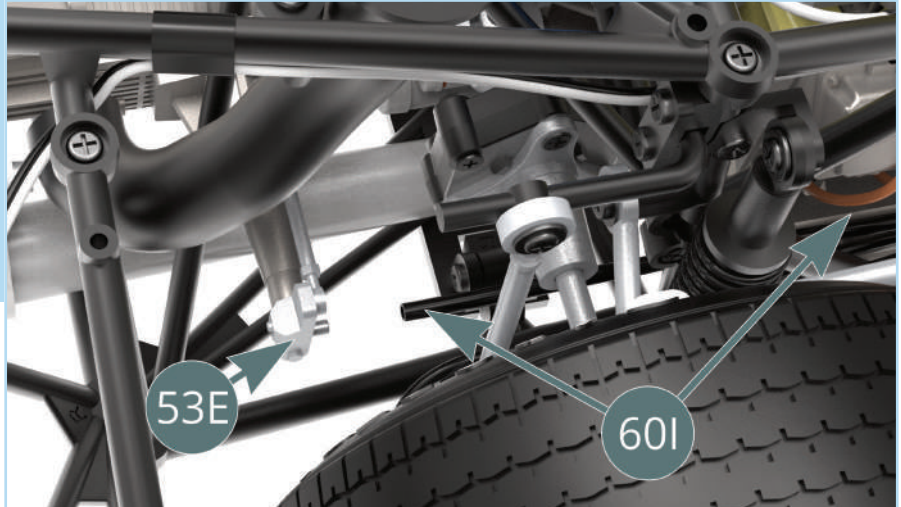

The gearbox rod, highlighted red, should run through and connect to the support as shown in the image.

STEP 6

Press the pin of the **gear lever (60H)** into the hole located in the **tubular frame (34A)**.

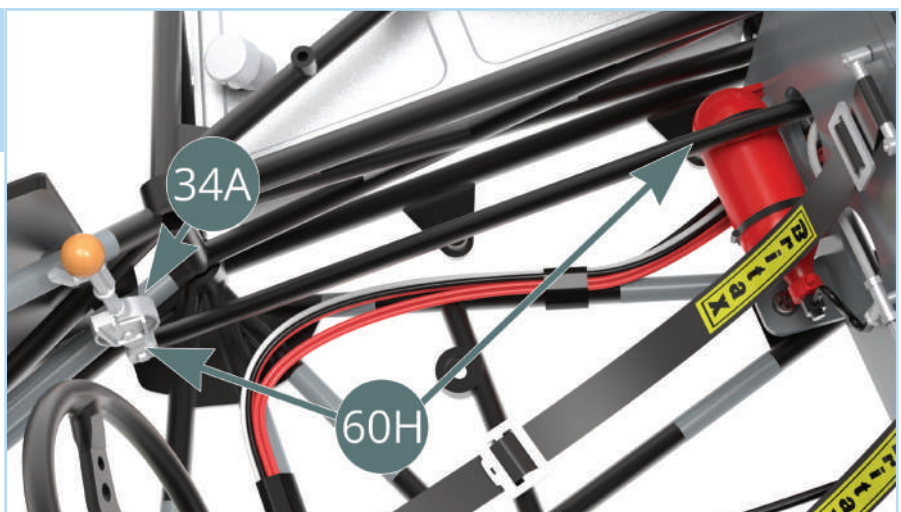

STAGE 60: ATTACHING THE BATTERY AND THE GEAR LEVER

STAGE COMPLETE

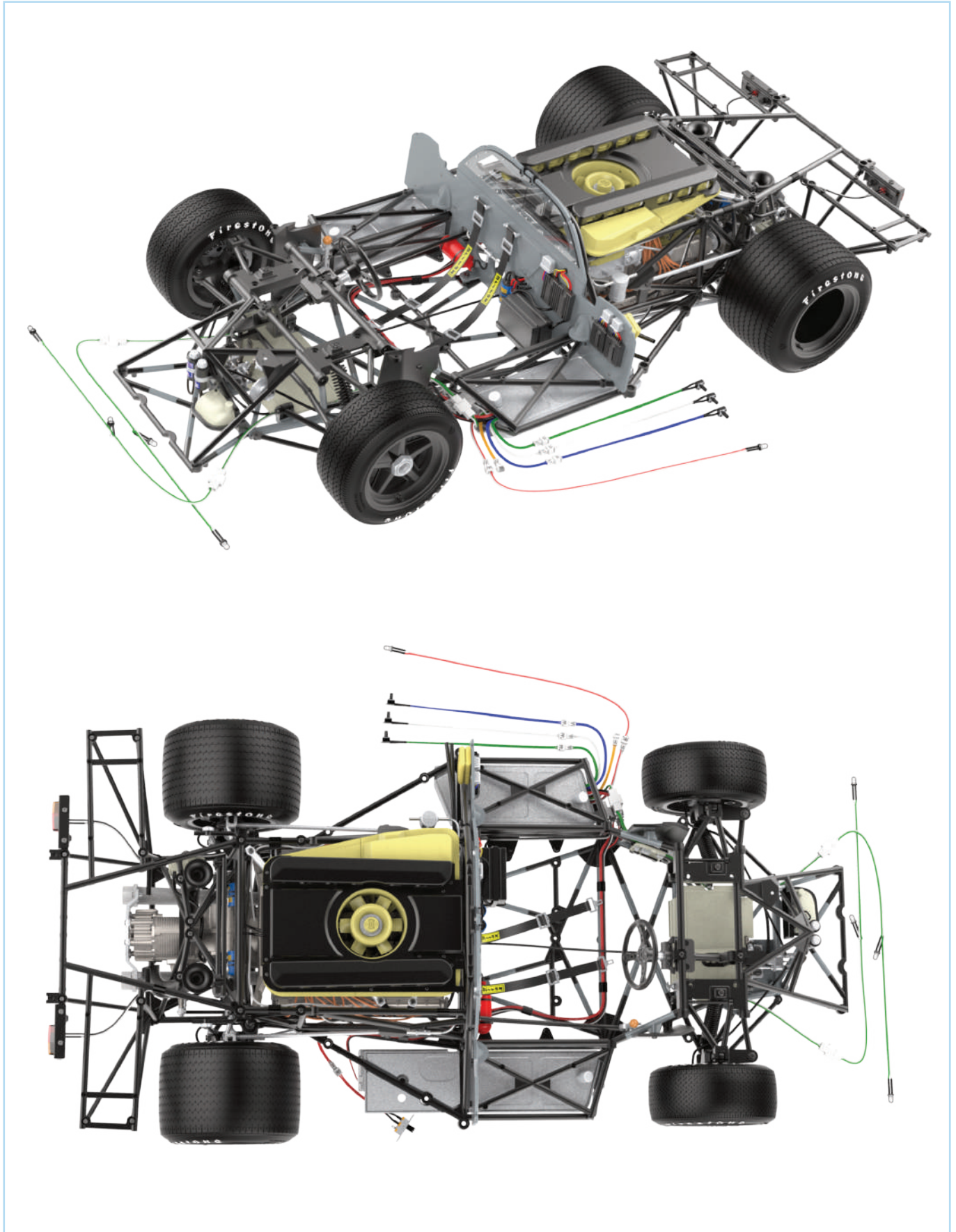

STAGE 61: FITTING THE DRIVER SEAT

61A Driver seat upholstery

61B Driver seat

61C Lower safety belt

61D Buckle lock

61E Upper safety belt

61F Seat adjustment lever

61G Adhesive tape (x5)

AP Screws 1.7 x 4 mm (x5)

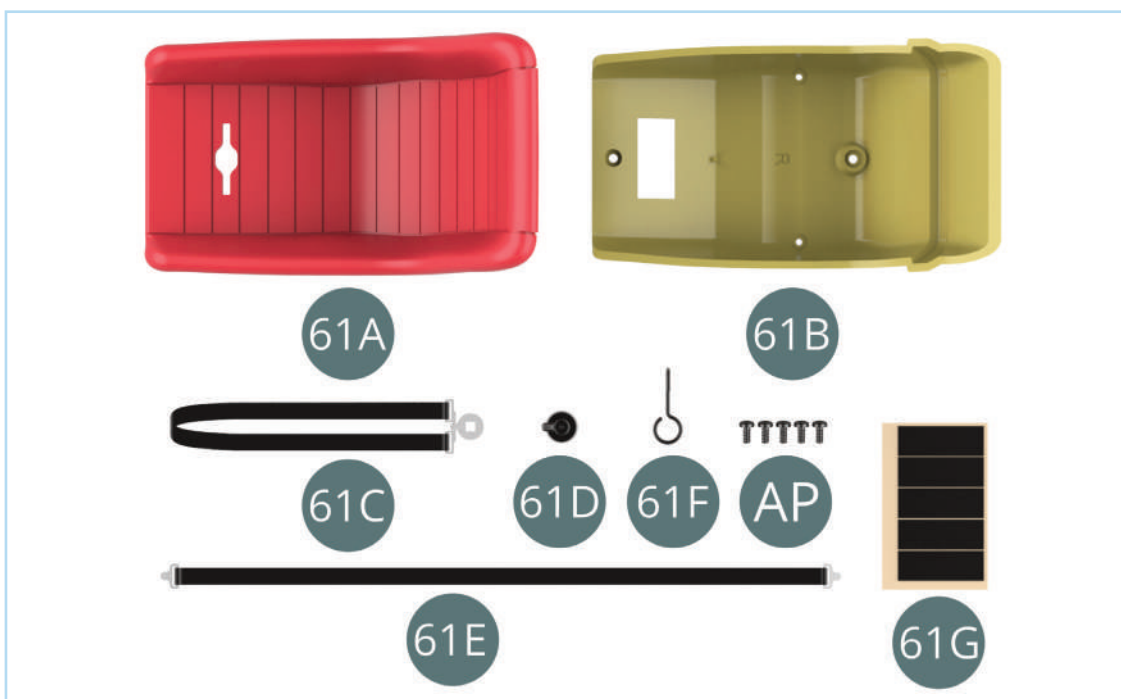

ASSEMBLY DIAGRAM

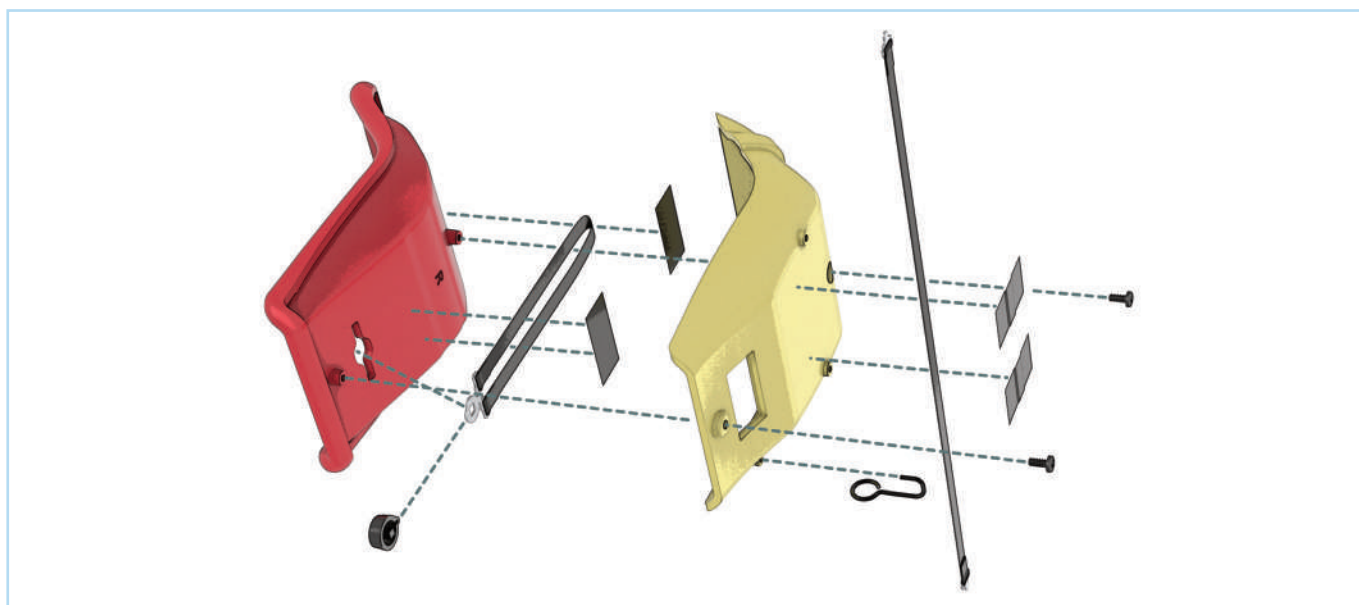

STAGE 61: FITTING THE DRIVER SEAT

ASSEMBLY DIAGRAM

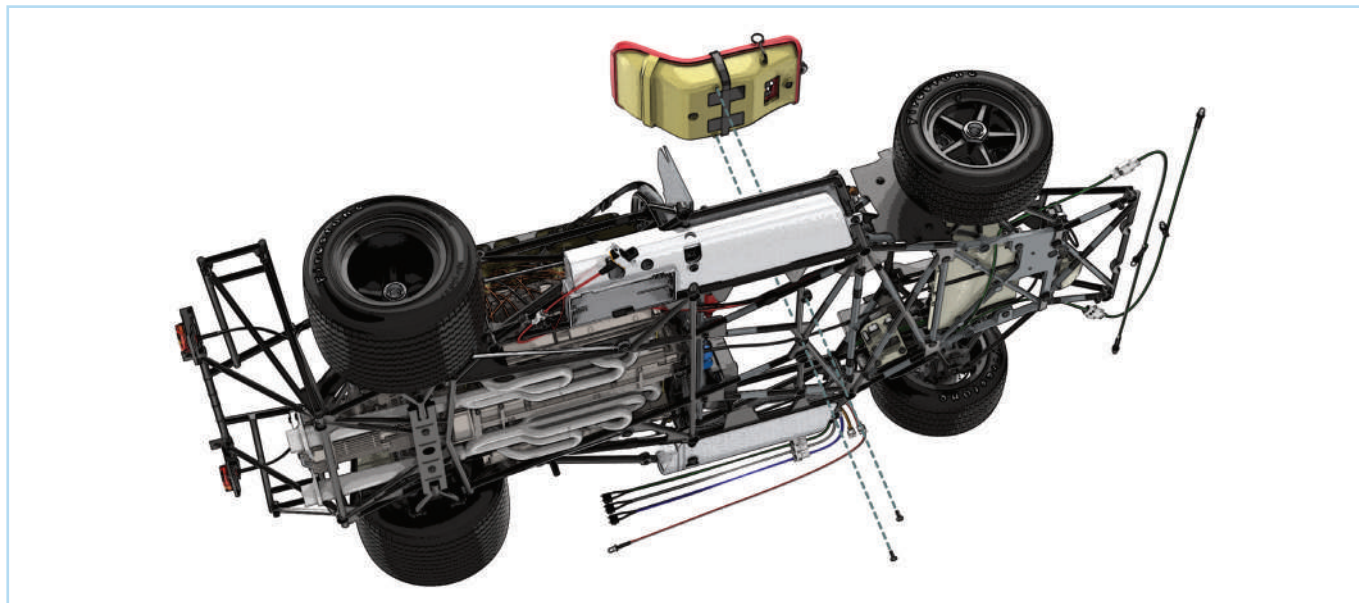

STEP 1

Pass the **lower safety belt (61C)** through the slot in the **driver seat upholstery (61A)** as shown by the blue arrow. Angle the silver connector of the belt, then align and fit the **buckle lock (61D)** into it.

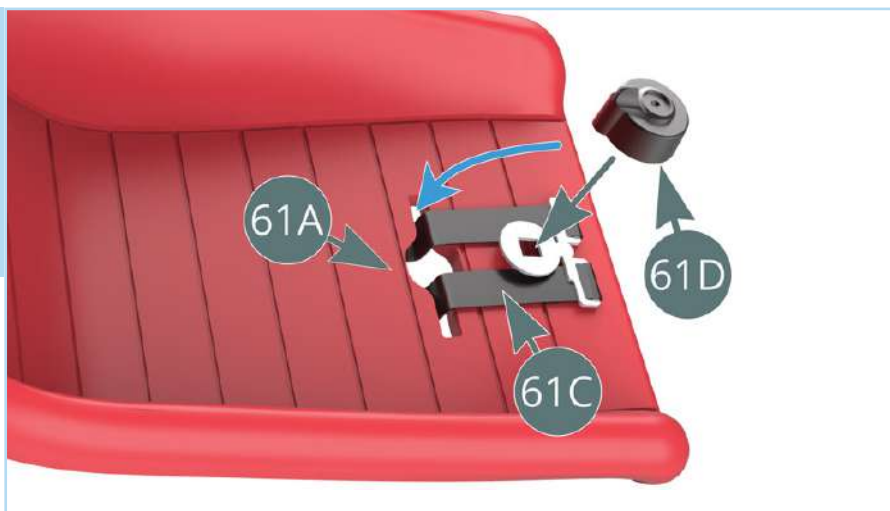

Turn the seat over and loop the opposite end of the **lower safety belt (61C)** around the pin (blue arrow) on the **upholstery (61A)**. Secure the belt in place using two strips of **adhesive tape (61G)**.

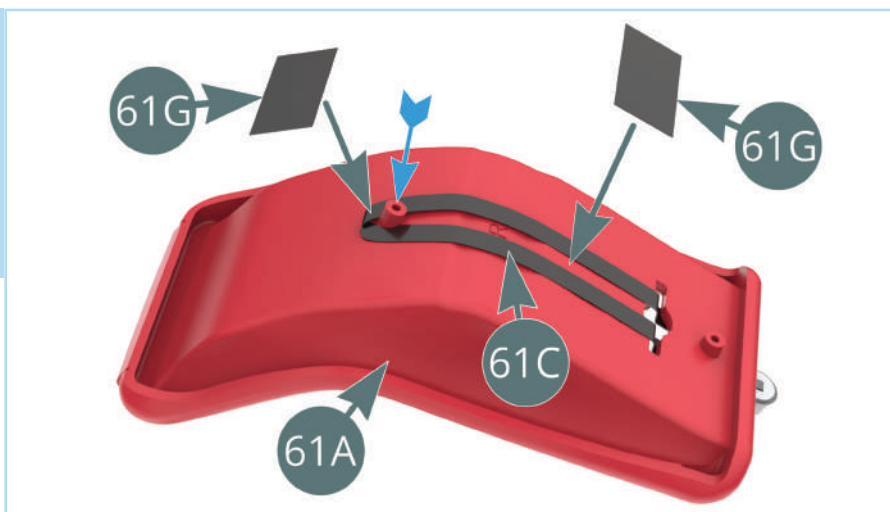

STAGE 61: FITTING THE DRIVER SEAT



The lower safety belt and buckle lock should look like this once fitted to the upholstery.

STEP 2

Fit the **driver seat (61B)** onto the **driver seat upholstery (61A)** then secure together using two **AP** screws.

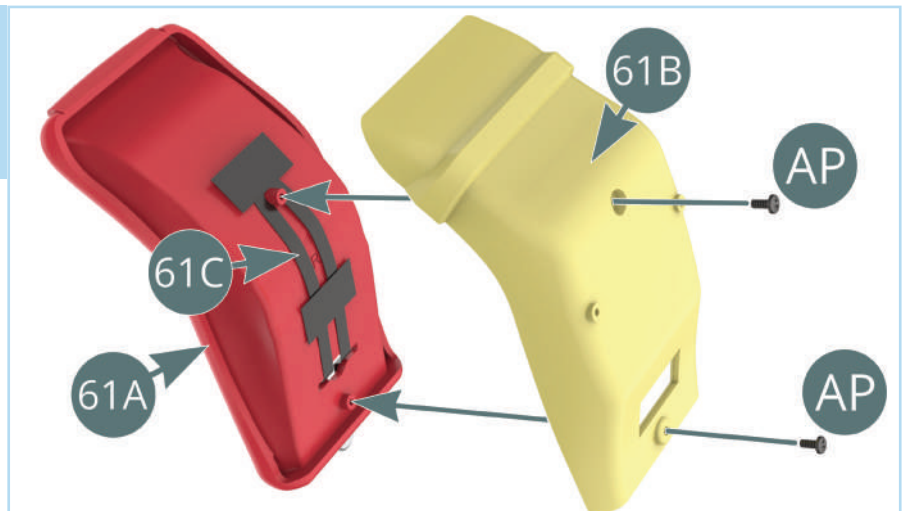

STEP 3

Position the midpoint of the **upper safety belt (61E)** halfway across the base of the **driver seat (61B)** as shown by the red arrow. Secure it in place using two pieces of **adhesive tape (61G)**. Make sure there is a gap of at least 2 mm from the screw hole, as indicated by the blue arrows.

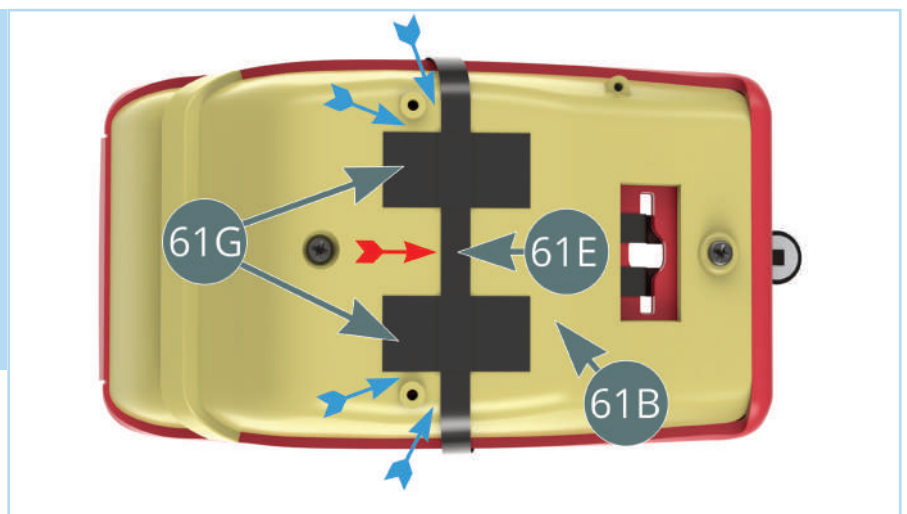

STAGE 61: FITTING THE DRIVER SEAT

STEP 4

Align the **seat adjustment lever (61F)** with the seat as shown, then press it into the hole located on the right side of the **driver seat (61B)**.

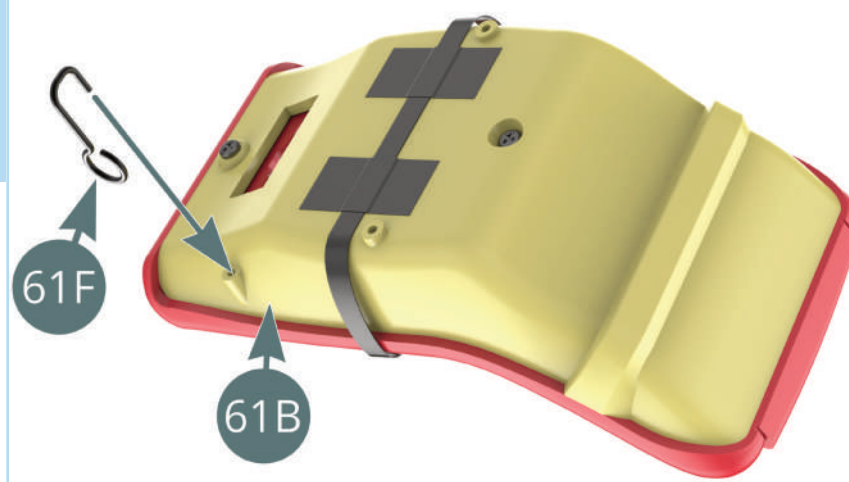

STEP 5

Move the **clutch cable (26J)** to the left side of the model as shown, so it is not in the way when fitting the seat in place. Mount the **driver seat (61B)** onto the **chassis (25A)**.

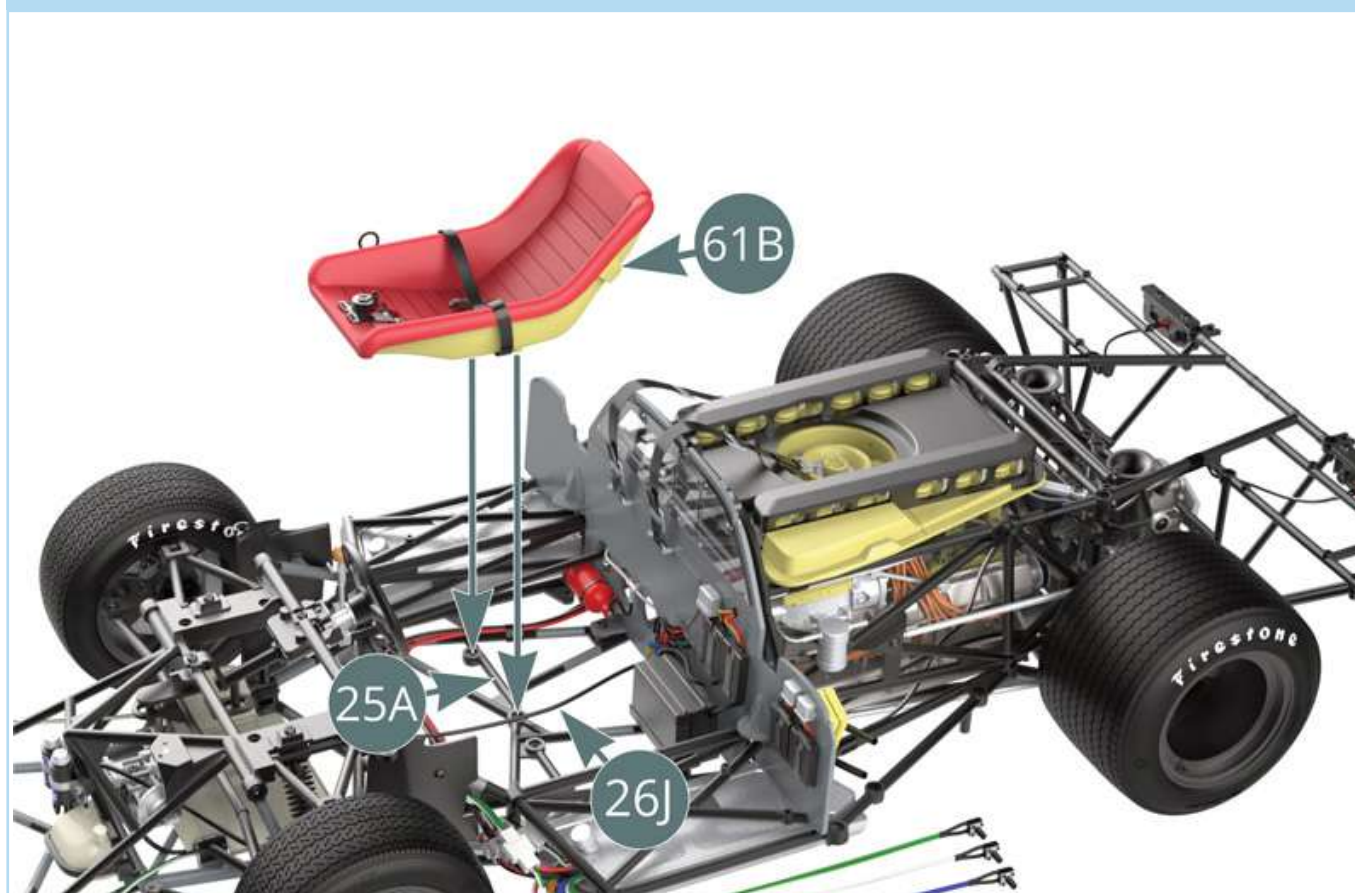

STAGE 61: FITTING THE DRIVER SEAT

STEP 6

While holding the seat in place, carefully turn the assembly over then secure the **driver seat (61B)** to the **chassis (25A)** using two **AP** screws.

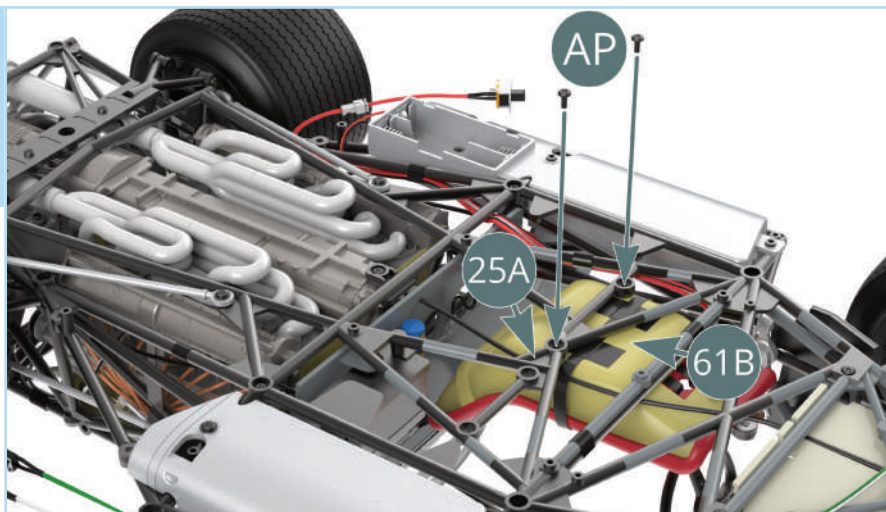

The driver seat has been secured to the chassis. Arrange the belts as shown in the image – you may need to work the belts by pinching them or running them over a rounded surface (such as a screwdriver or paint brush handle) to get them to conform properly. You can also use a small piece of adhesive tack to keep the belts in place.



STAGE 61: FITTING THE DRIVER SEAT

STAGE COMPLETE

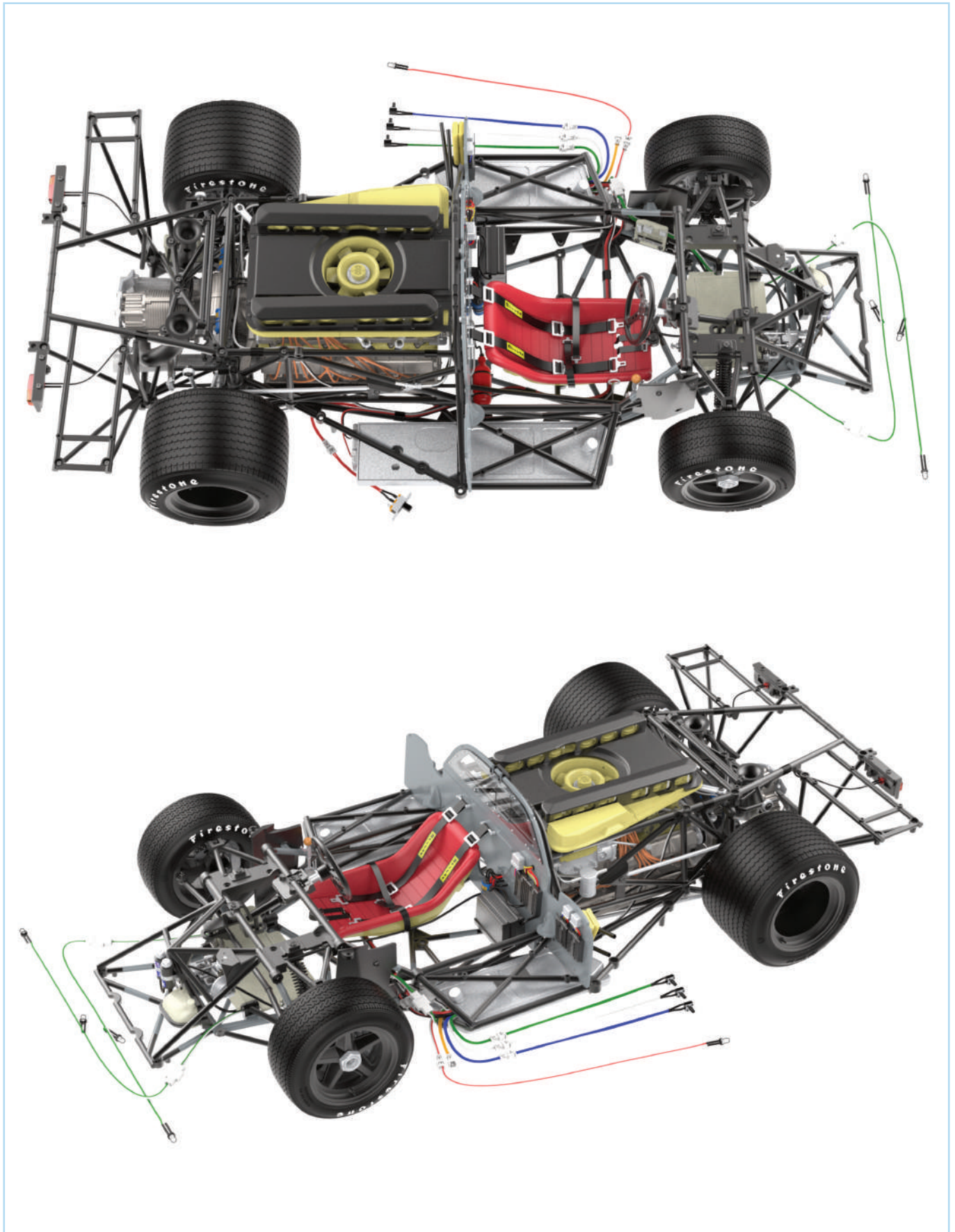

STAGE 62: FITTING THE PASSENGER SEAT

62A Passenger seat upholstery

AP Screws 1.7 x 4 mm (x5)

62B Passenger seat

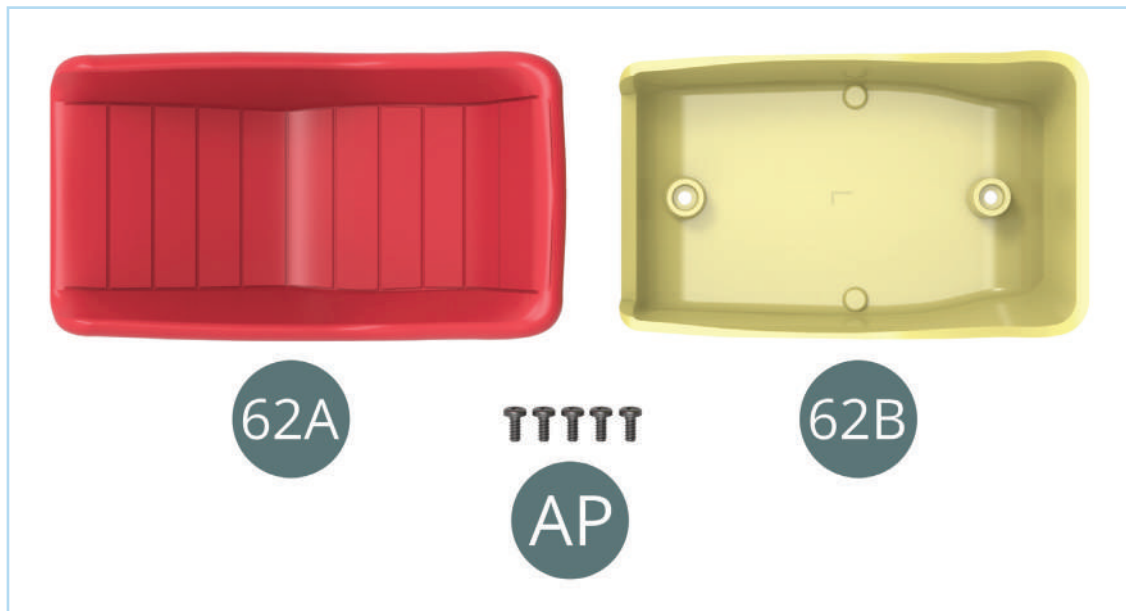

ASSEMBLY DIAGRAM

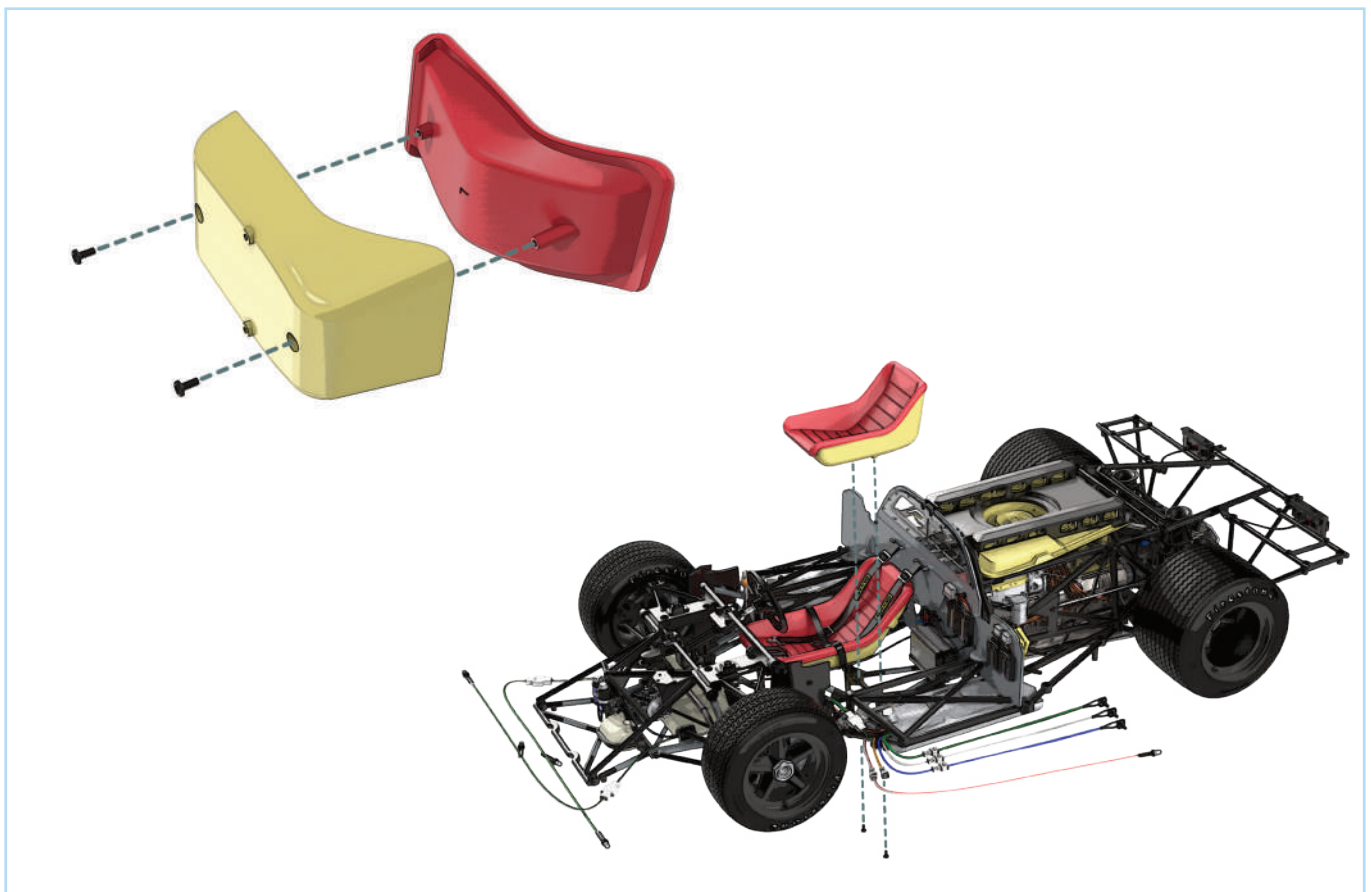

STAGE 62: FITTING THE PASSENGER SEAT

STEP 1

Mount the **passenger seat upholstery (62A)** into the **passenger seat (62B)** and secure using two **AP** screws.

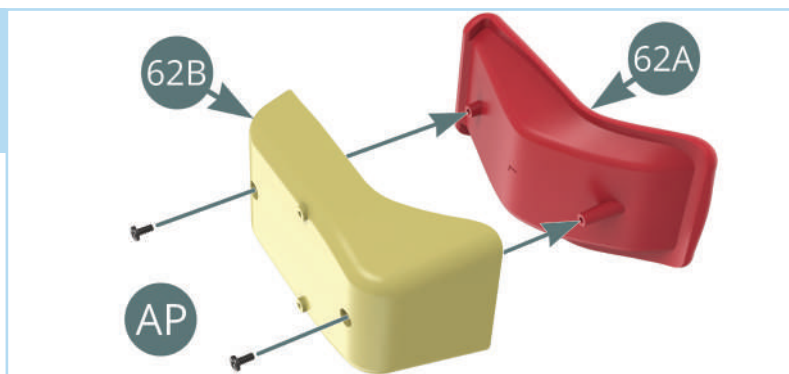

Fit the columns under the **passenger seat (62B)** into the holes of the **chassis (25A)**, next to the driver seat.

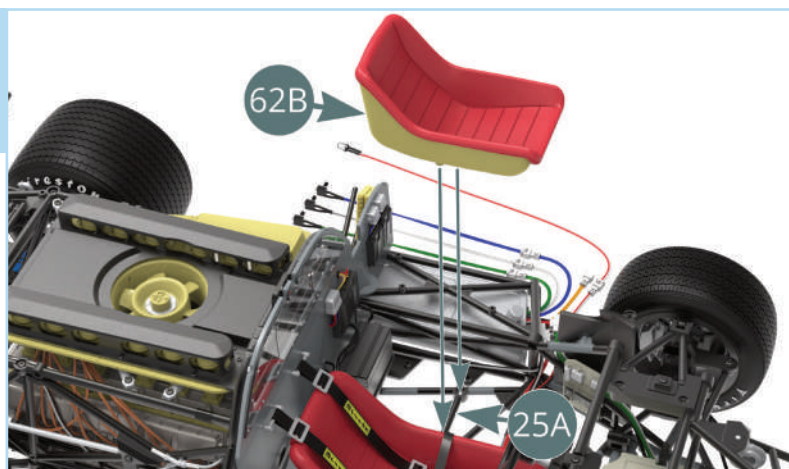

STEP 2

Turn the assembly over while holding the passenger seat in place, then secure it using two **AP** screws.

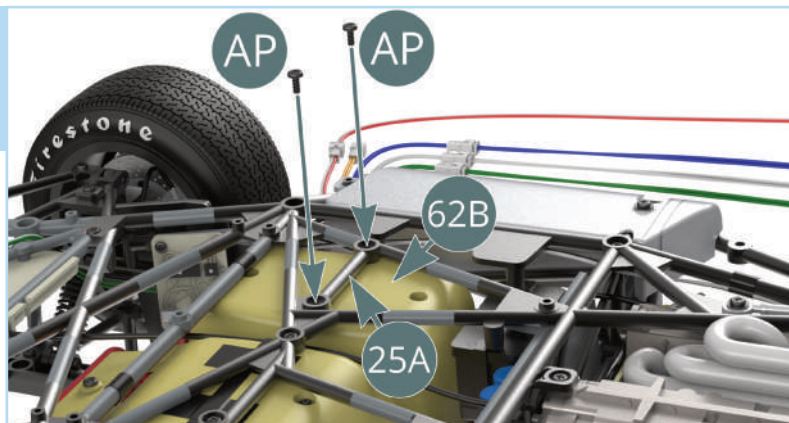

The passenger seat and the driver seat have been fixed to the chassis.

STAGE 62: FITTING THE PASSENGER SEAT

STAGE COMPLETE

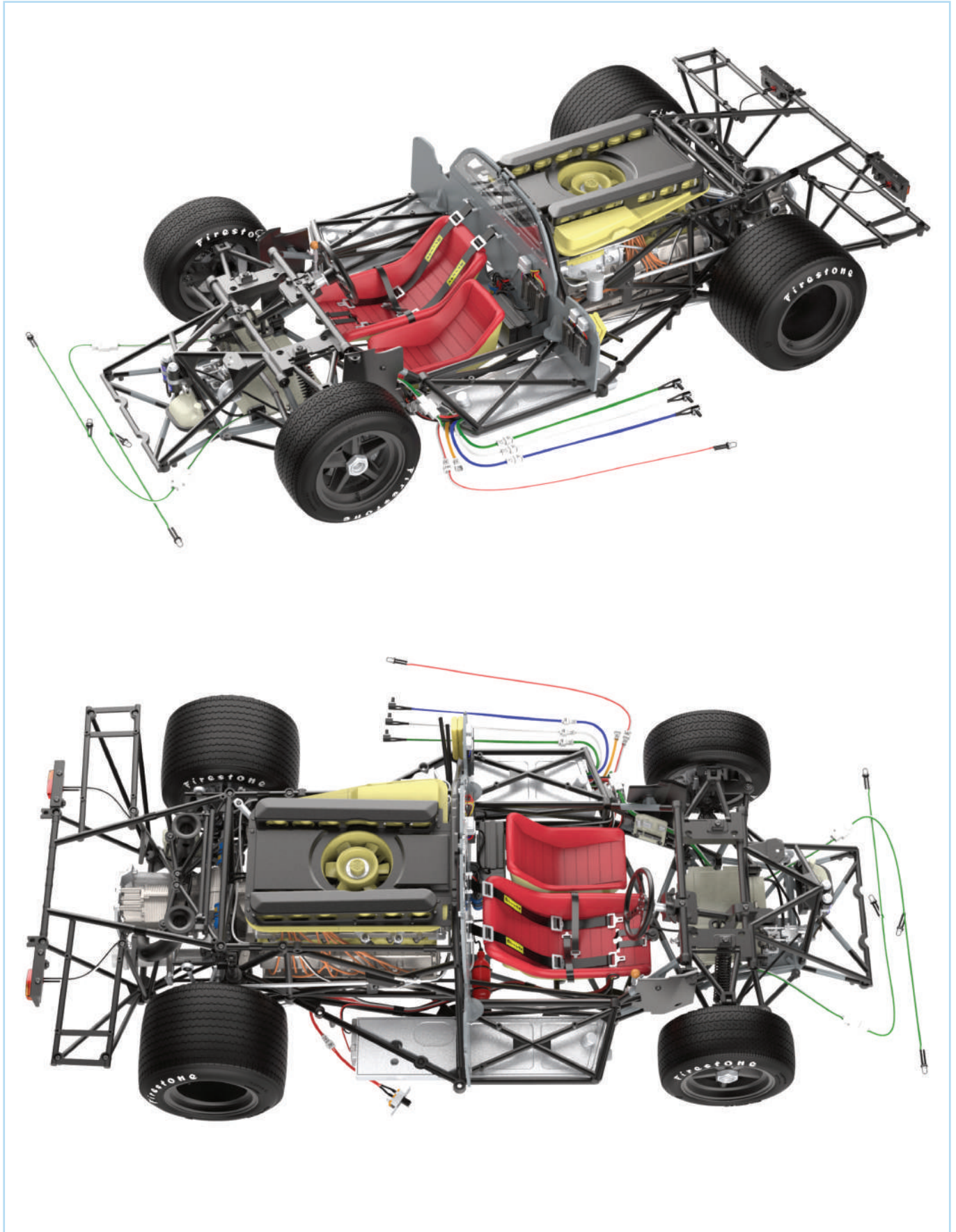

STAGE 63: DETAILING THE DASHBOARD

63A Dashboard

63B Master cut-off switch

63C Starter switch

63D Ignition key

63E Dashboard decal (x2)



ASSEMBLY DIAGRAM

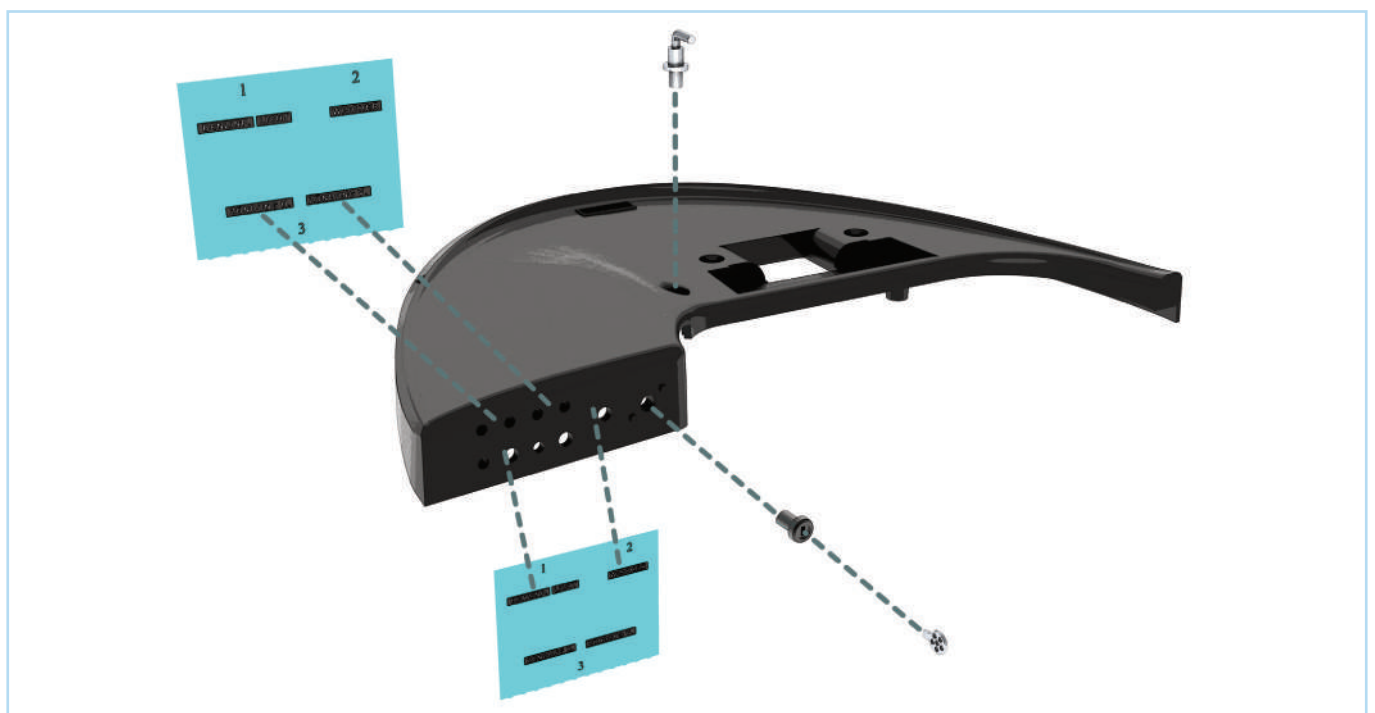

STAGE 63: DETAILING THE DASHBOARD

STEP 1

Align the **master cut-off switch (63B)** with the **dashboard (63A)** as shown, then press it into the hole of the dashboard.

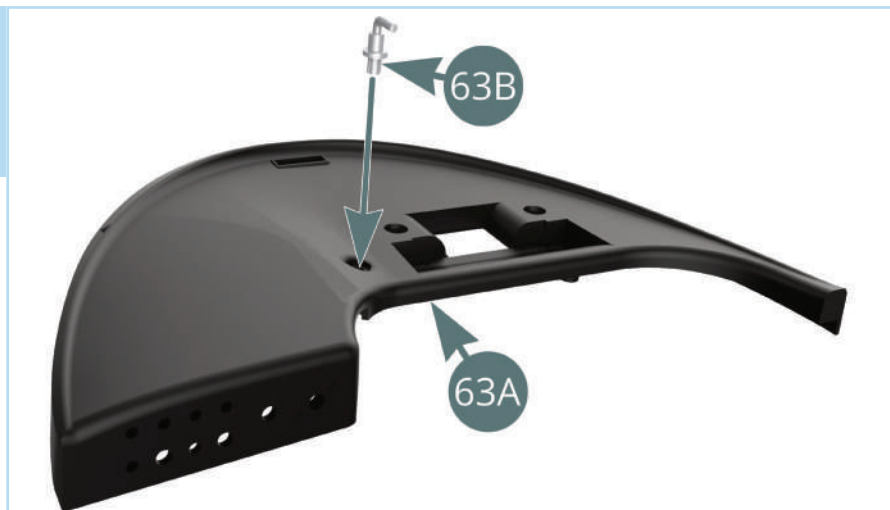

STEP 2

Detach the **starter switch (63C)** from the sprue as shown by the red arrow.

Your starter switch may already be detached from the sprue. Check the packaging carefully as this is quite a small part!

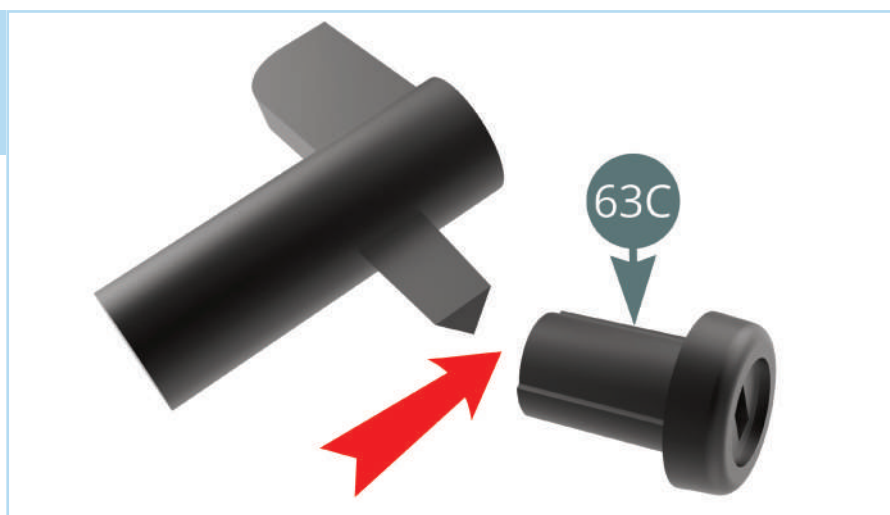

Press the **starter switch (63C)** into the hole of the **dashboard (63A)** as shown.

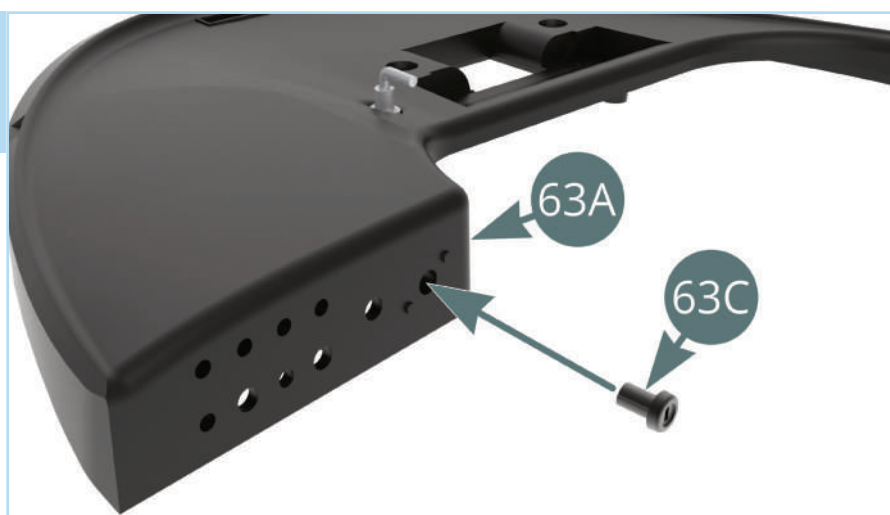

STAGE 63: DETAILING THE DASHBOARD

Although this stage includes the decals for the dashboard, you may wish to apply them after completing Step 6 of Stage 64 to avoid damaging them during assembly of the switches.

STEP 3

Separate the two sheets of **dashboard decals (63E)** from each other. Keep one safely aside to use for spares if necessary. Prepare a container of water for dipping the decals. We also recommend using a small paint brush to help apply the decals and to adjust their position once applied.

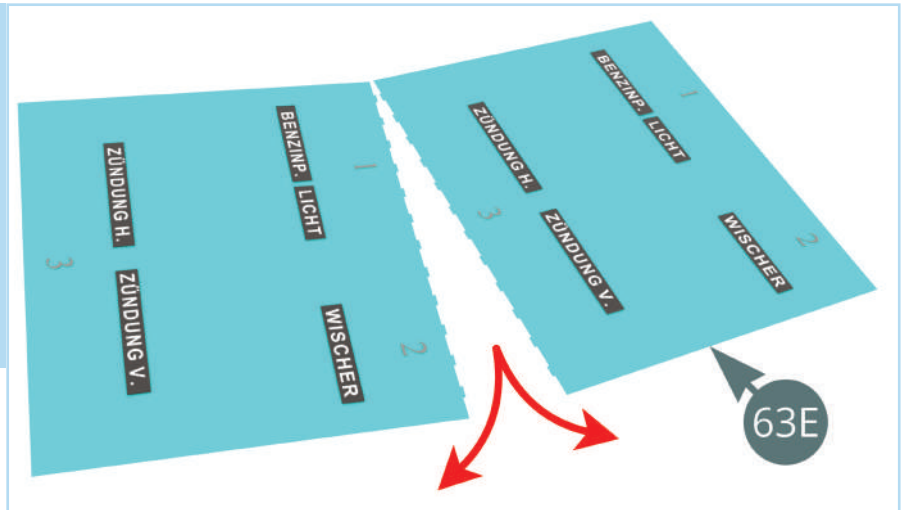

Dip the decal (63E-3) in water for 15 – 20 seconds until the decal begins to slide freely.

We suggest cutting the decals into three sections, as shown by the dashed red line, to make transferring the decals easier.



Apply the **decal (63E-3)** above the four holes on the **dashboard (63A)** as shown. Use the paint brush to move the decal into place.

You can use the tips of the brush hairs to nudge the decal into position, then carefully flatten out any air pockets in the decal. The corner (orange arrow) of the decal may need to be pressed down to adhere to the curve of the dashboard.

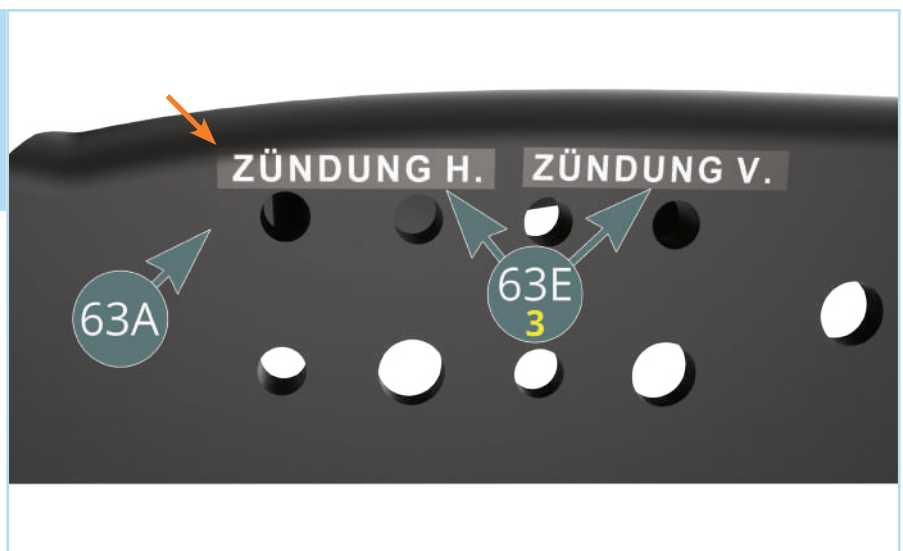

STAGE 63: DETAILING THE DASHBOARD

STEP 4

Dip the **decal (63E-1)** in water for 15 – 20 seconds. Apply the **decal (63E-1)** above the three holes on the **dashboard (63A)**, in the same manner as before.

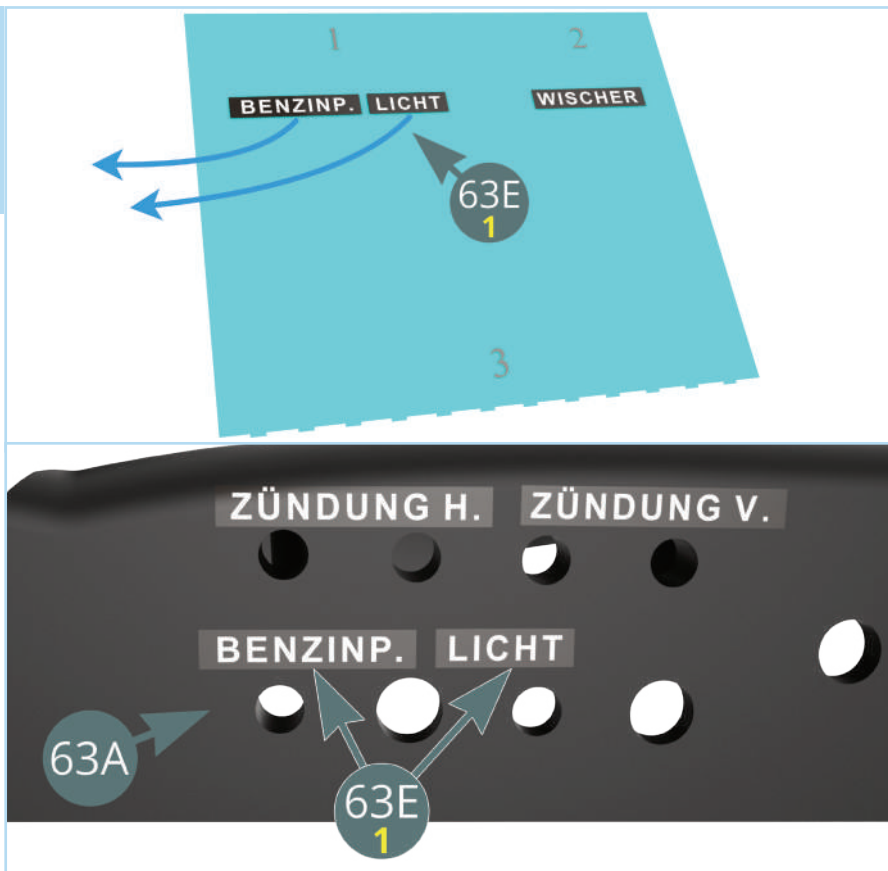

STEP 5

Dip the **decal (63E-2)** in water for 15 – 20 seconds, then apply the **decal (63E-2)** above the hole on the **dashboard (63A)** as shown.

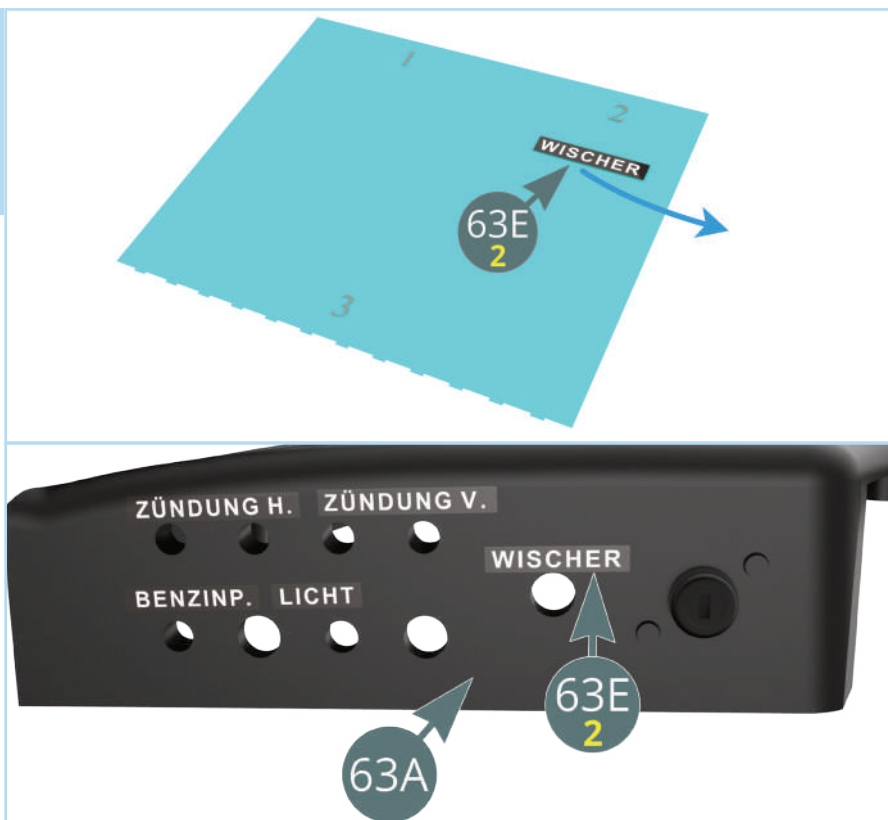

STAGE 63: DETAILING THE DASHBOARD

STEP 6

Insert the **ignition key (63D)** into the **starter switch (63C)**. You may need to apply a small drop of super glue to hold it firmly in place.

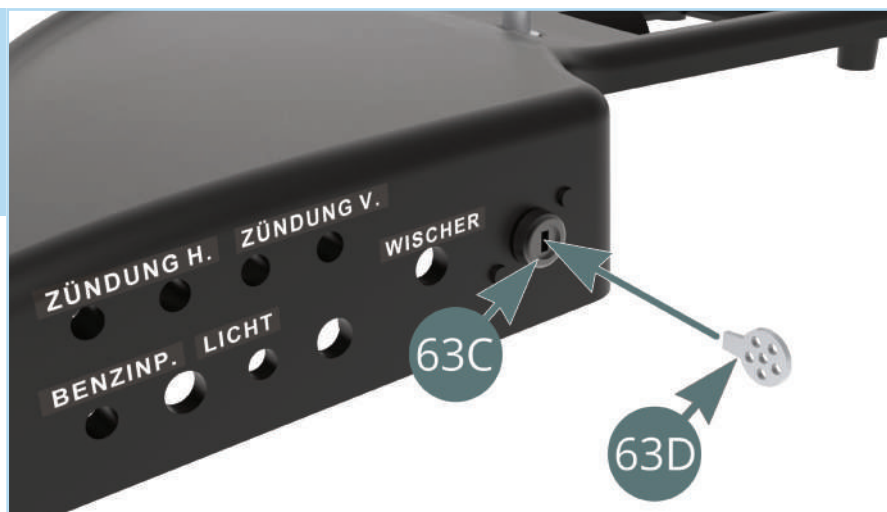

STAGE COMPLETE



STAGE 64: FITTING THE SWITCHES AND THE INSTRUMENT PANEL

64A Instrument panel cover

64B Instrument panel

64C Dials

64D Reflector panel

64E Button housing

64F Switch panel

64G Knob

64H Key switch

64I Switch (x6)

64J Screw head (x2)

64K Indicator light

64L Switch (x2)

64M Switch

AP Screws 1.7 x 4 mm (x8)

MP Screws 2.0 x 5 mm (x5)

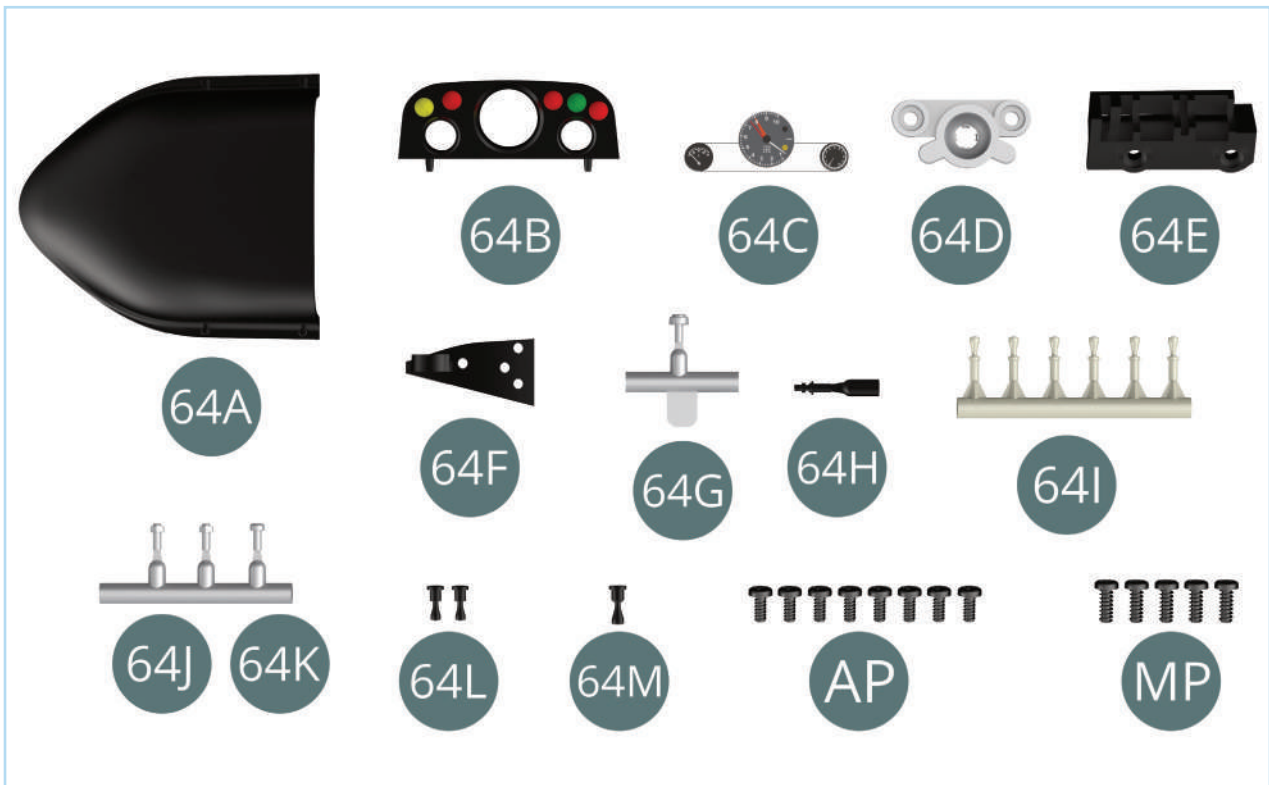

STAGE 64: FITTING THE SWITCHES AND THE INSTRUMENT PANEL

ASSEMBLY DIAGRAM

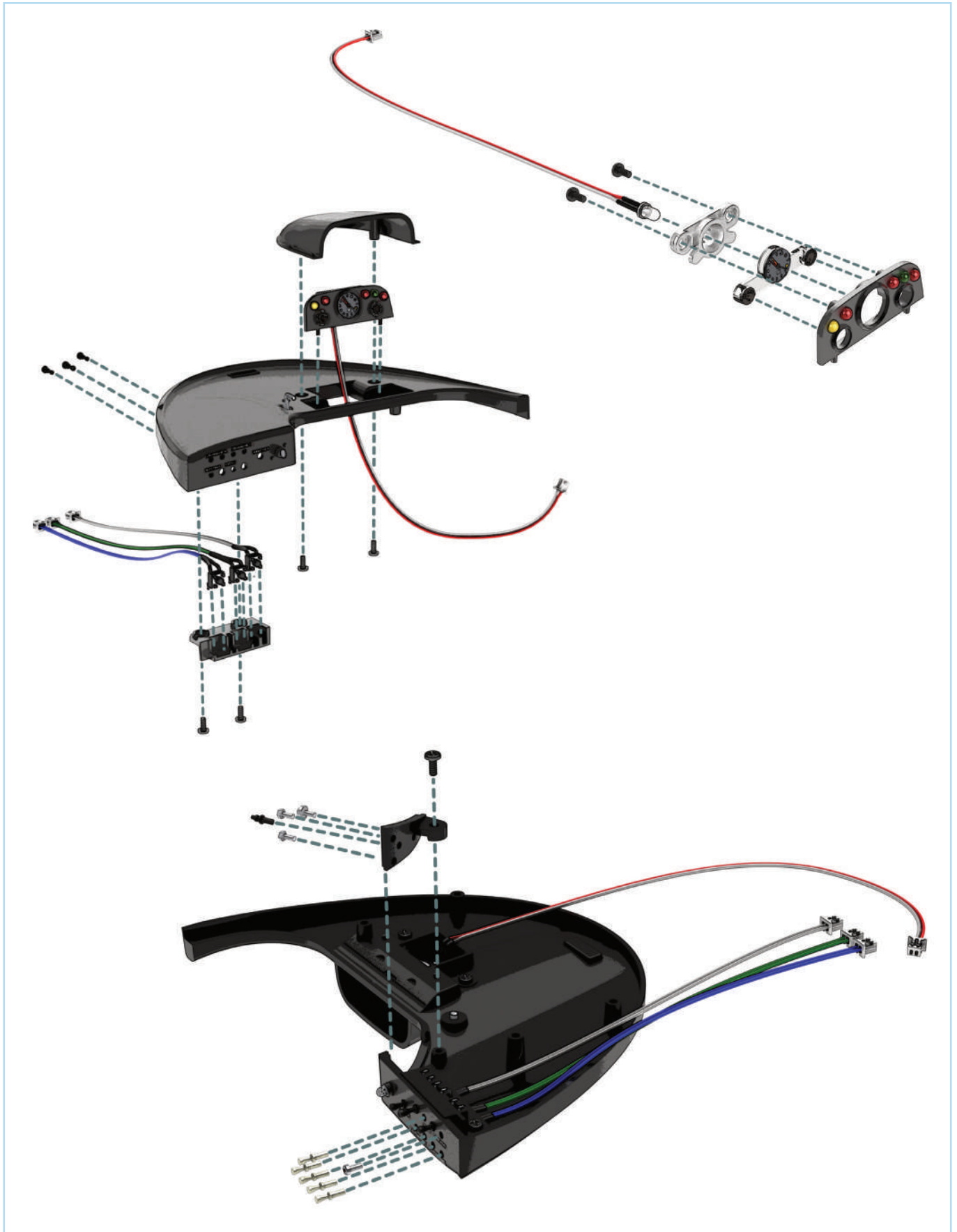

STAGE 64: FITTING THE SWITCHES AND THE INSTRUMENT PANEL

STEP 1

Take the chassis assembly and place it on the work surface. Disconnect the **horn sound switch (green) (34E)**, the **light switch (white) (35H)**, the **engine sound switch (blue) (34D)** and the **instrument light LED (red-white) (35I)**.

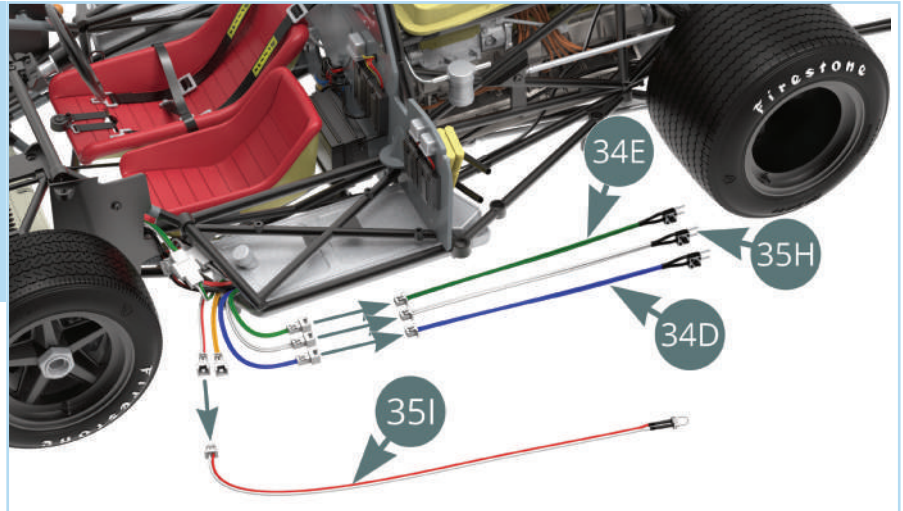

Insert the silver contacts of the **horn sound switch (green) (34E)**, the **light switch (white) (35H)**, and the **engine sound switch (blue) (34D)** into the slots (red arrows) of the **button housing (64E)**.

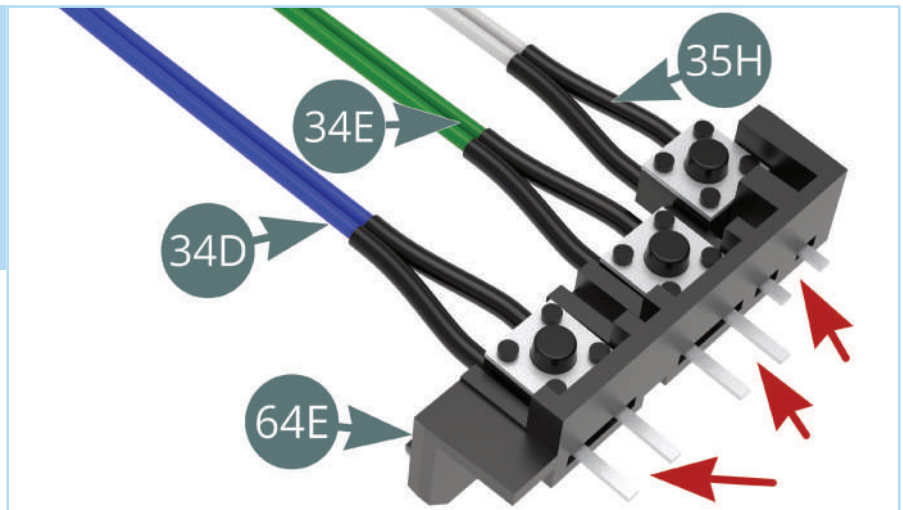

STEP 2

Turn the assembly upside down and bend the silver contacts over the **button housing (64E)** as shown by the blue arrows.

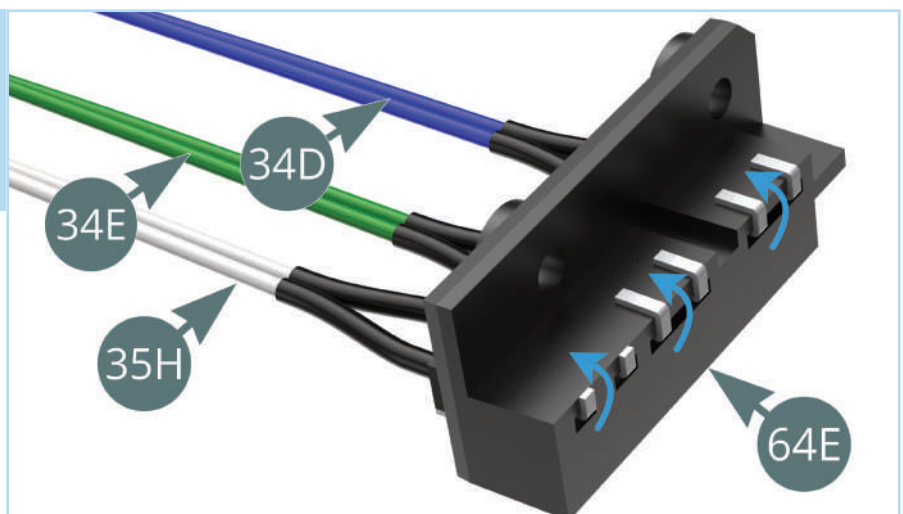

STAGE 64: FITTING THE SWITCHES AND THE INSTRUMENT PANEL

Bend the black sections of the cables of the **horn switch (green) (34E)**, **light switch (white) (35H)** and **engine sound switch (blue) (34D)** to fit around the two fixing holes in the **button housing (64E)**, as indicated by the blue arrows.

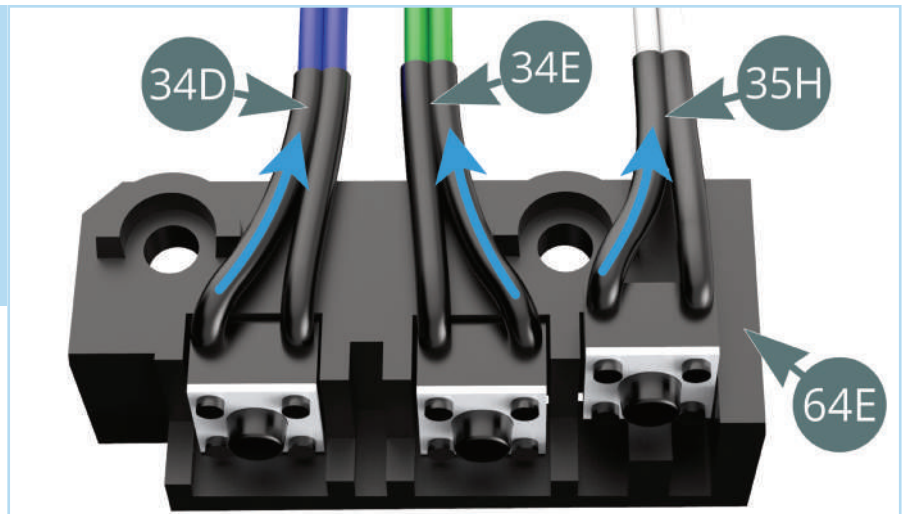

STEP 3

Fit the **dials (64C)** into the **instrument panel (64B)**, then position the **reflector panel (64D)** over them as shown. Secure the parts together using two **AP** screws.

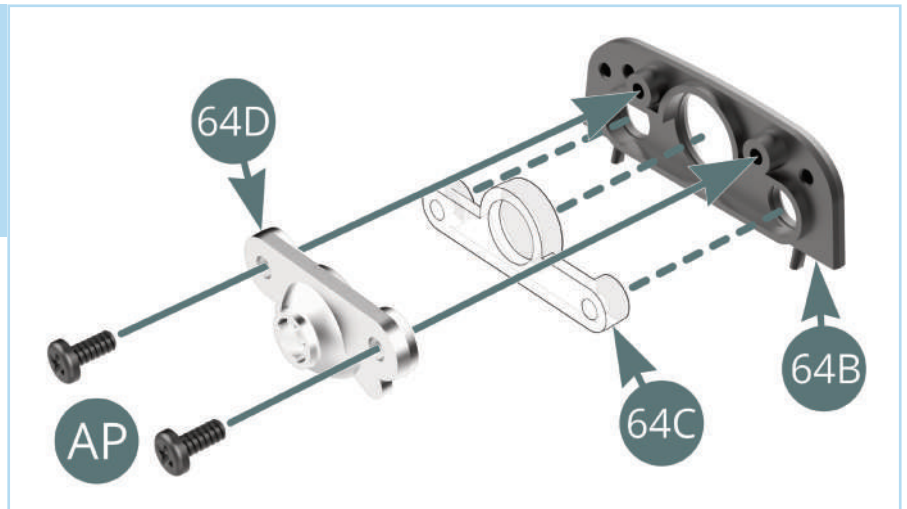

Push the bulb end of the **instrument light LED (red-white) (35I)** into the **reflector panel (64D)**.

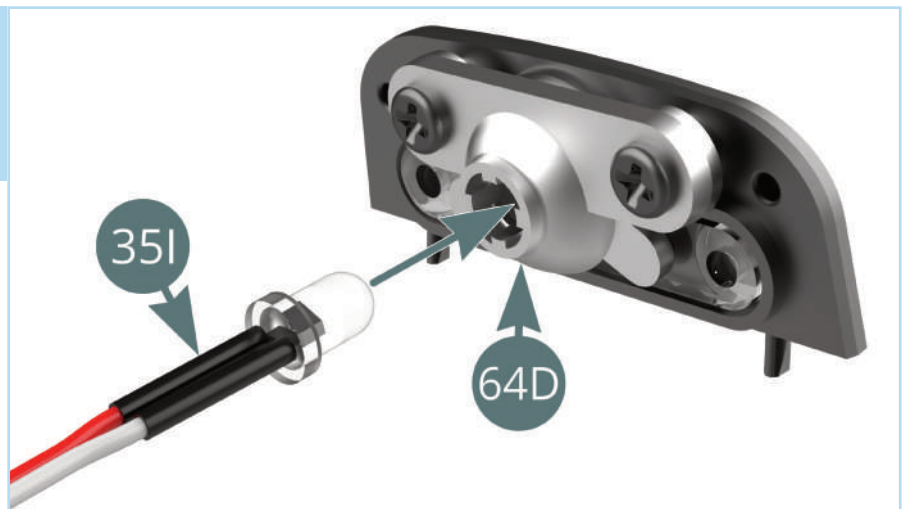

STAGE 64: FITTING THE SWITCHES AND THE INSTRUMENT PANEL

STEP 4

Align the **instrument panel (64B)** with the **dashboard (63A)** as shown, then bend the **instrument light LED (red-white) (35I)** cable and pass it through the opening. Fit the two pins of the instrument panel into the corresponding holes of the dashboard.

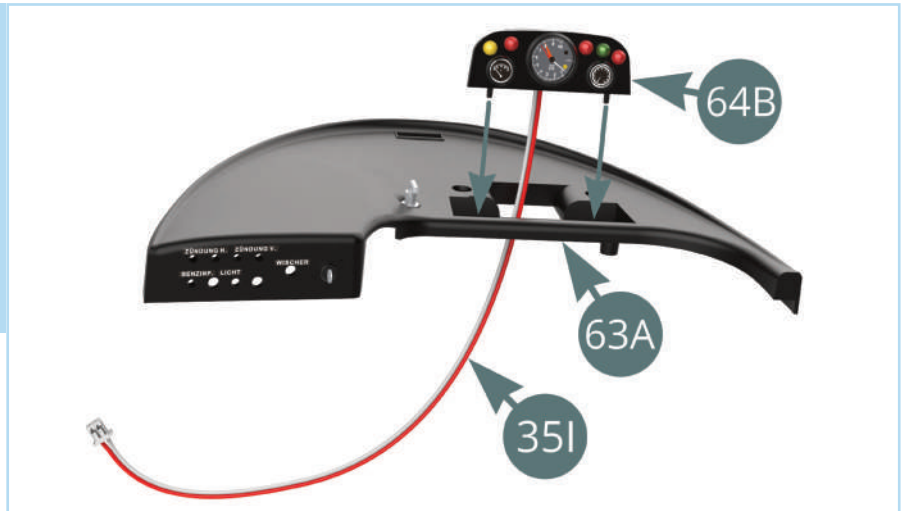

Position the **instrument panel cover (64A)** over the **instrument panel (64B)** as shown. Drive two **AP** screws through from underneath the **dashboard (63A)** to secure it in place.

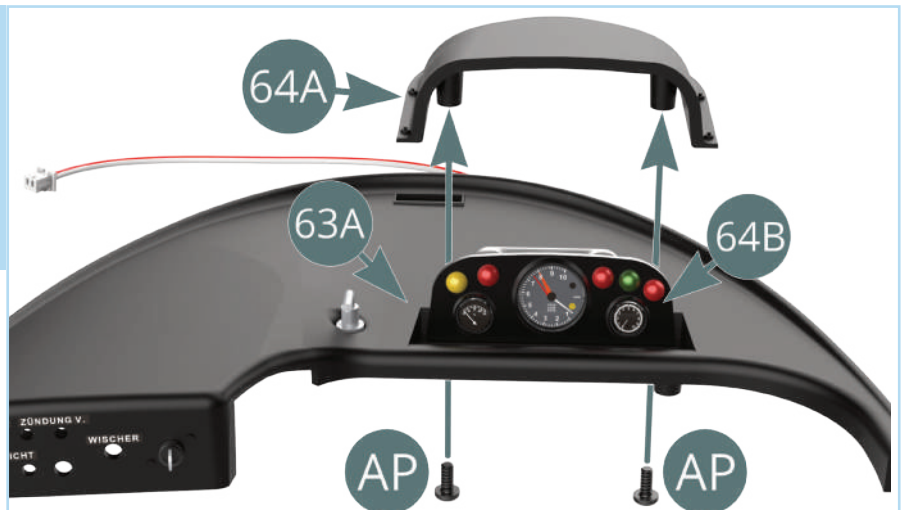

STEP 5

Push the two smaller black **switches (64L)** into the 'WISCHER' and larger 'BENZINP.' holes, then fit the larger **switch (64M)** into the holes between them as shown.

Do not glue the switches, they are used to operate the electronics of the model. Take care not to damage the decals while fitting the switches.

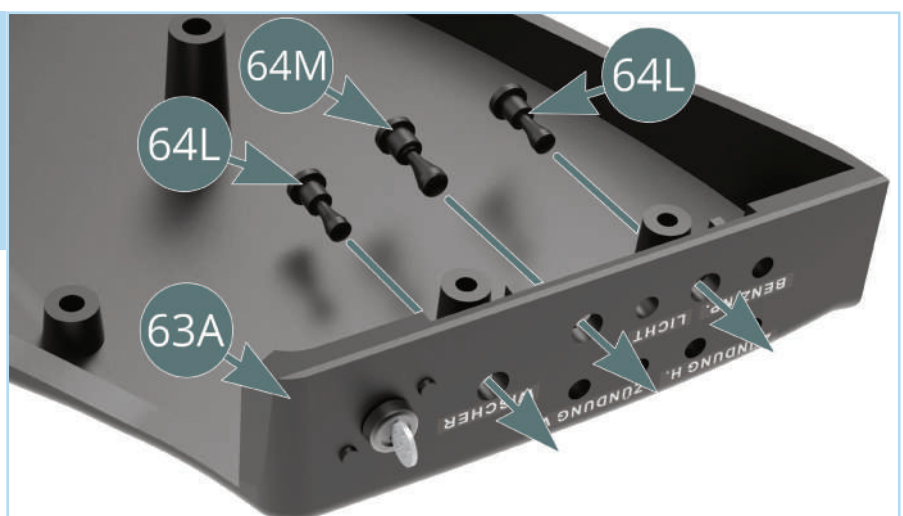

STAGE 64: FITTING THE SWITCHES AND THE INSTRUMENT PANEL

Align the **button housing (64E)** with the dashboard (63A) as shown. The three **switches (64L and 64M)** should align with the buttons of the panel as shown by the red, green and orange arrows.

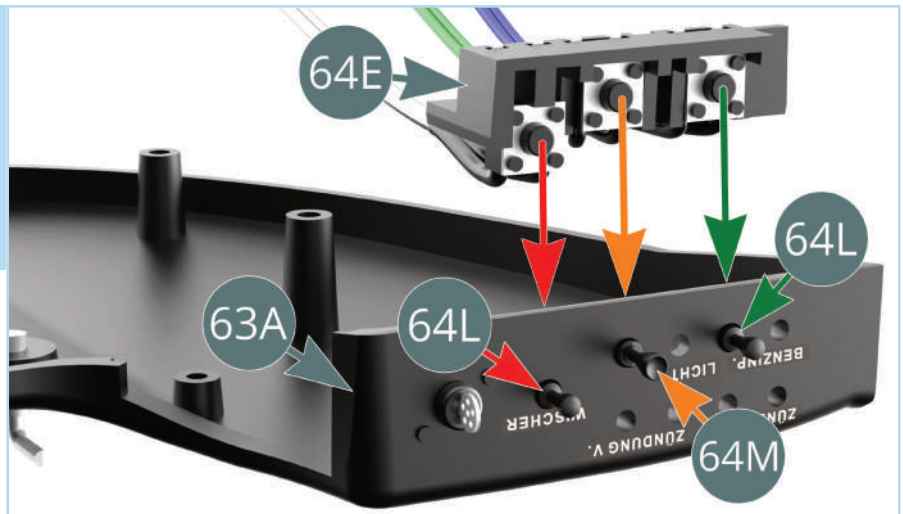

Mount the **instrument panel (64E)** in place, then secure it to the **dashboard (63A)** using two **AP** screws.

Test that each of the three buttons click by pressing in the three switches. If any of the buttons don't click, remove the panel and check their position, or carefully file away some of the contact point on the switch (if the button permanently pressed).

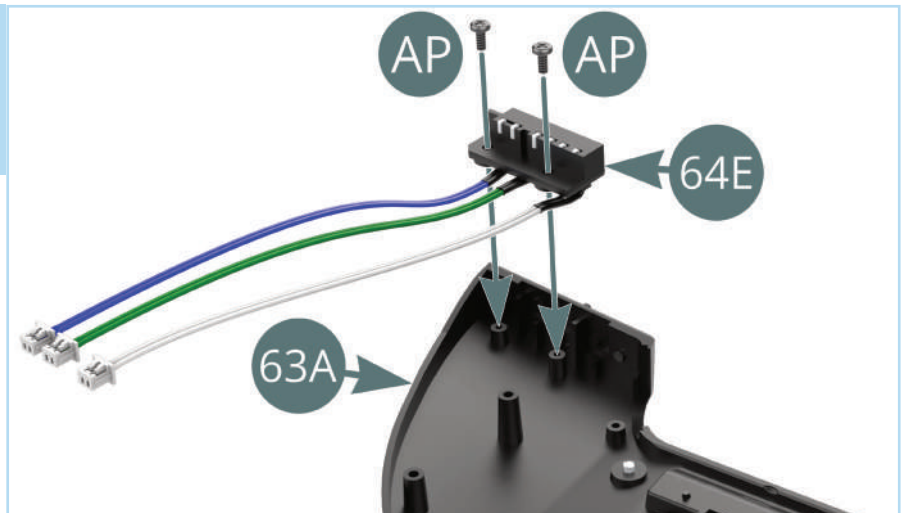

STEP 6

Detach the **indicator light (64K)** from its sprue as shown by the red arrow.

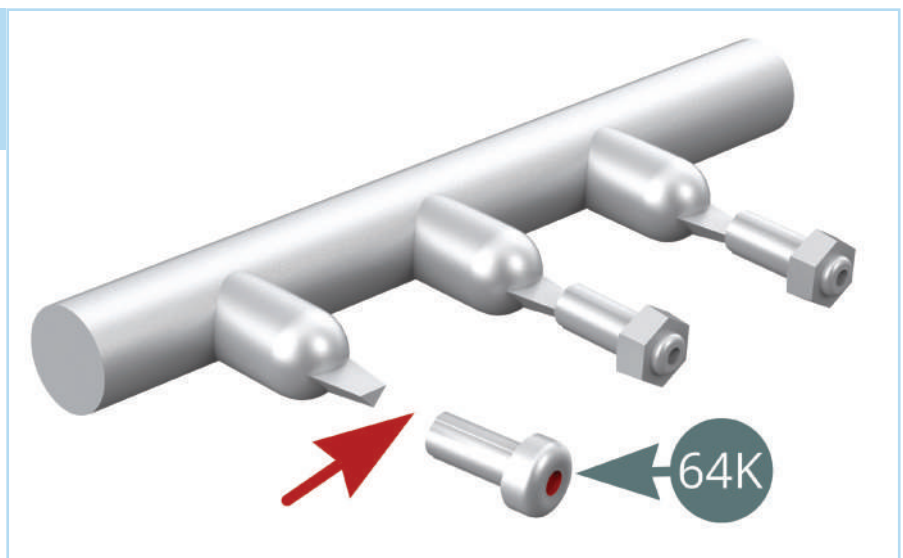

STAGE 64: FITTING THE SWITCHES AND THE INSTRUMENT PANEL

Cut five of the **switches (64I)** from their sprue at the point shown by the red arrow.

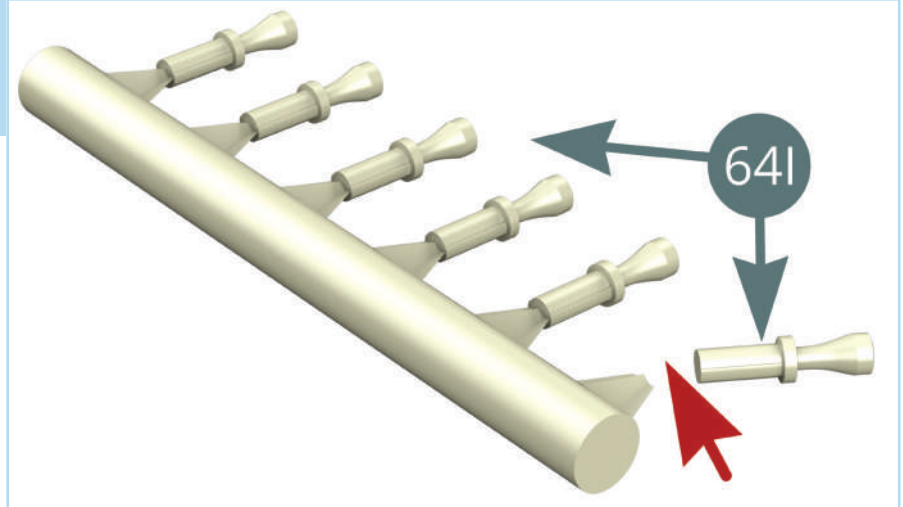

STEP 7

Press the **switches (64I)** and **indicator light (64K)** into the smaller holes of the **dashboard (63A)** as shown.

Take care not to damage the decals while fitting the switches. If you chose not to apply the decals in the previous stage, we suggest applying them before fitting the switches here.

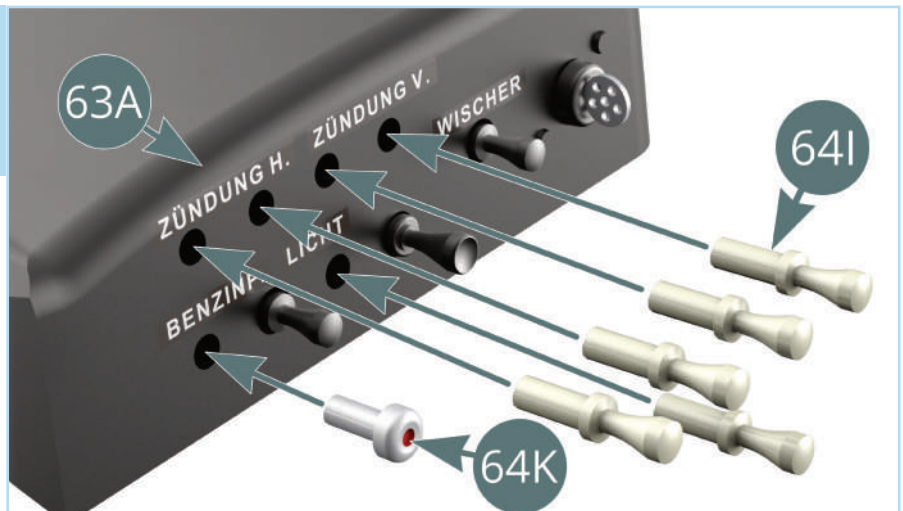

STEP 8

Detach the two **screw heads (64J)** from their sprue as indicated by the red arrow.

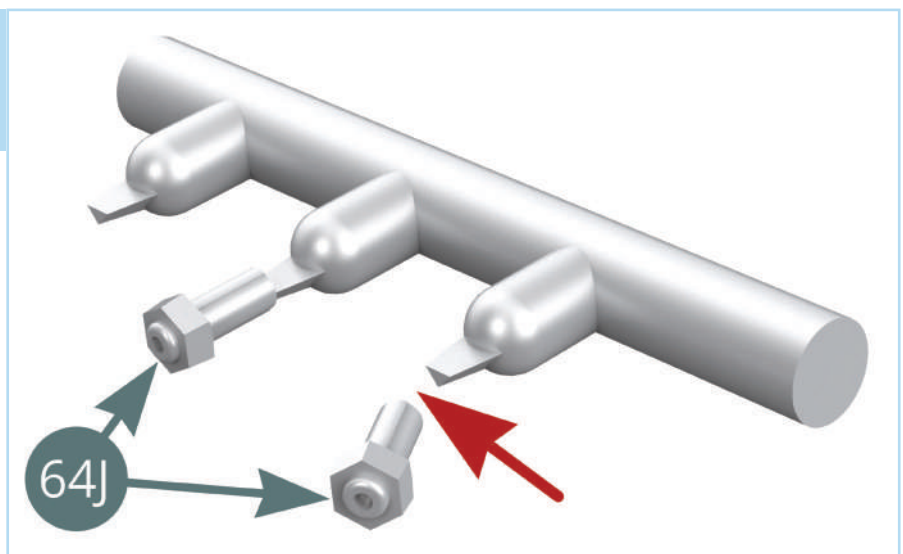

STAGE 64: FITTING THE SWITCHES AND THE INSTRUMENT PANEL

STEP 9

Press the **screw heads (64J)** into the textured side of the **switch panel (64F)**.

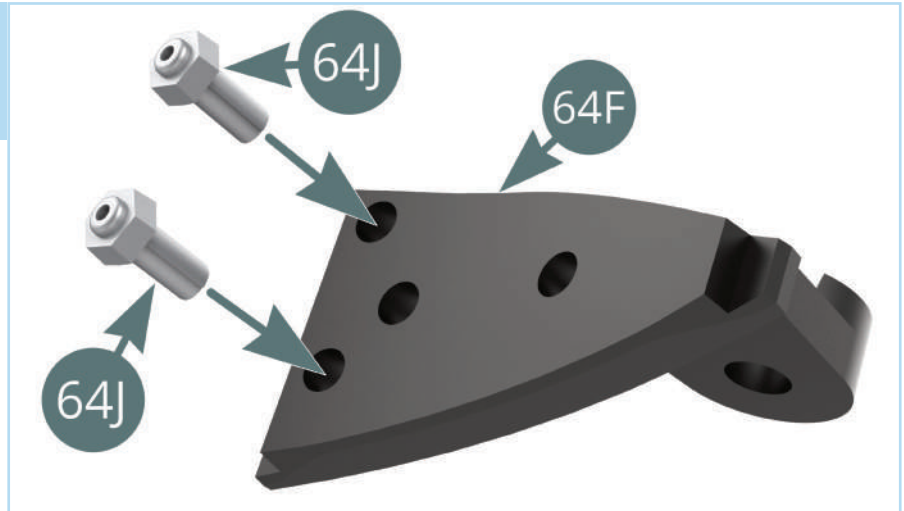

STEP 10

Detach the small black **key switch (64H)** from its sprue at the point shown.

This small part may already be detached from its sprue and kept in a separate bag from the others.

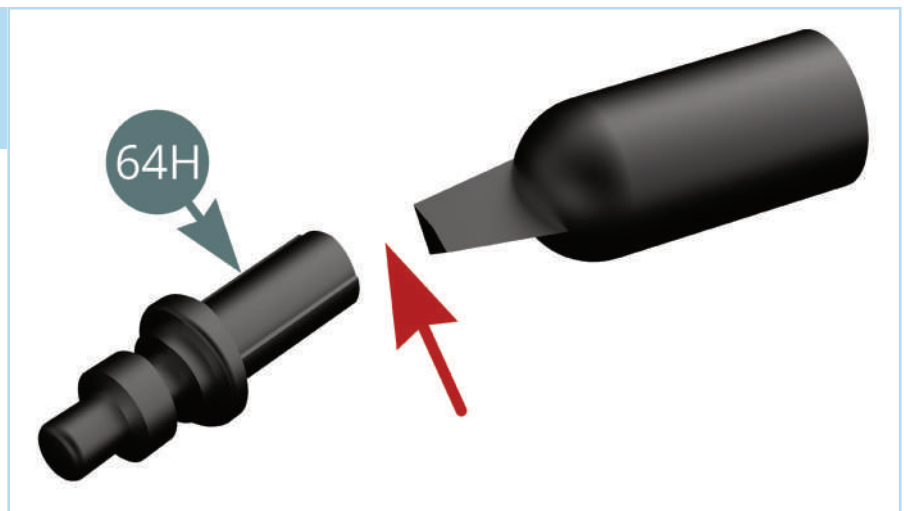

Detach the **knob (64G)** from its sprue at the point indicated by the red arrow.

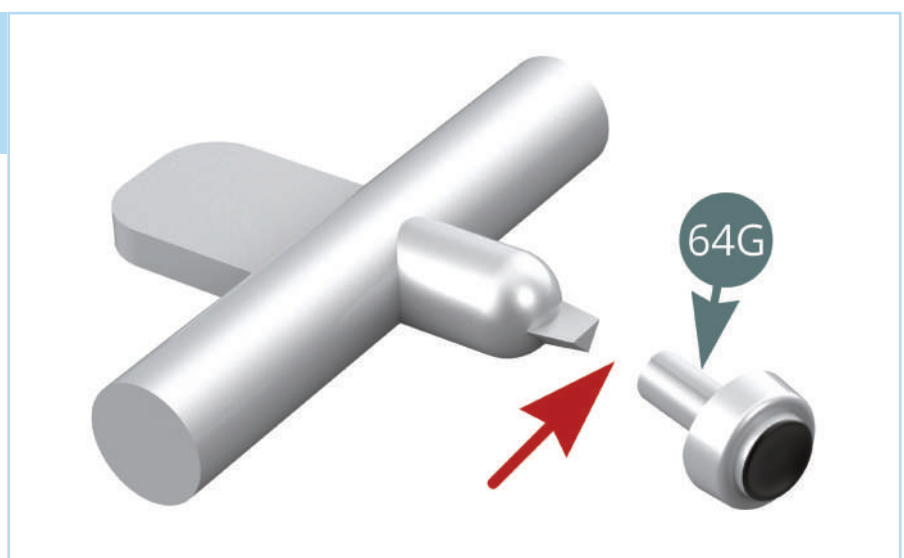

STAGE 64: FITTING THE SWITCHES AND THE INSTRUMENT PANEL

STEP 11

Press the **knob (64G)** and the **key switch (64H)** into the textured side of the **switch panel (64F)** as shown.

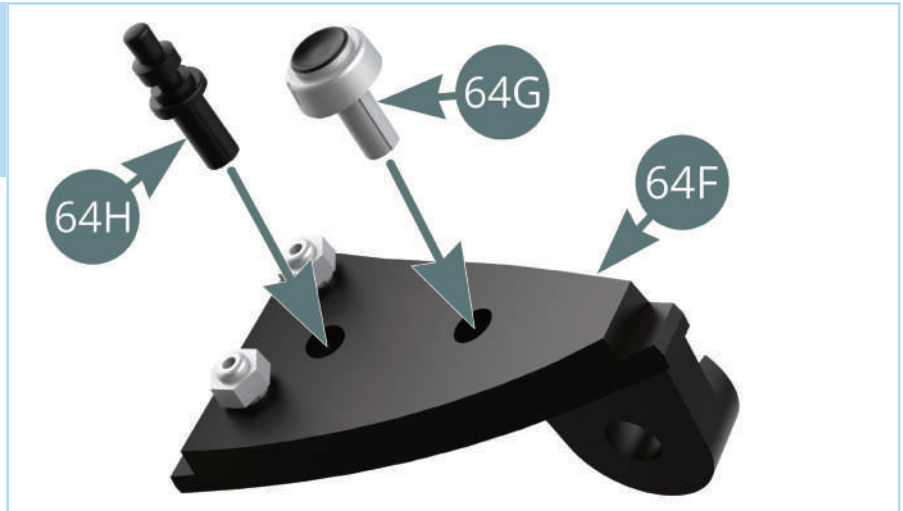

STEP 12

Align the **switch panel (64F)** with the **dashboard (63A)** as shown, then mount and secure it in place using an **AP screw**.

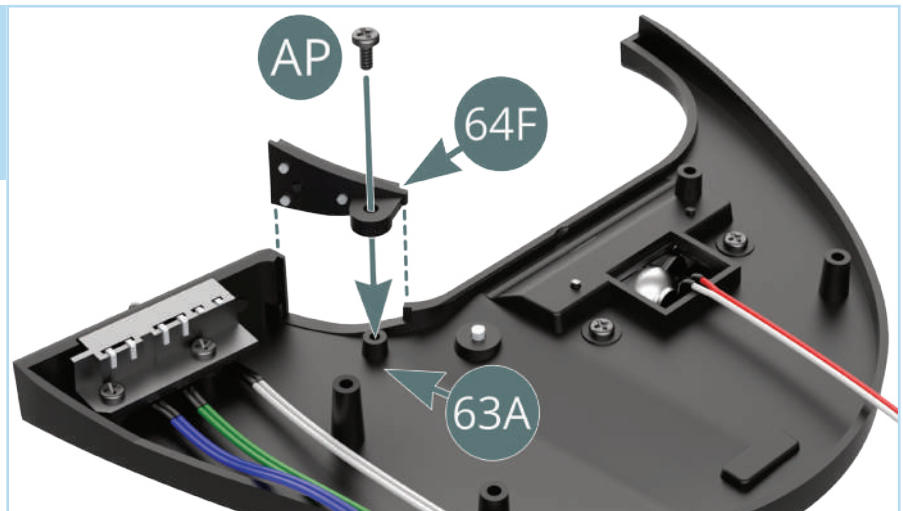

Bundle the blue, green, white and red-white cables and route them towards the left-hand side of the **dashboard (63A)**. To keep them from separating, you may wish to twist and knot them as shown by the blue and green arrows.

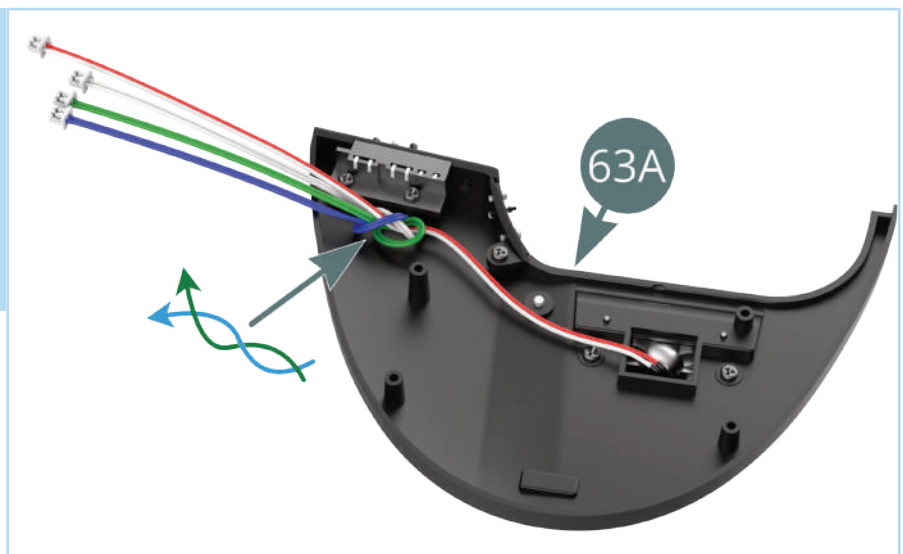

STAGE 64: FITTING THE SWITCHES AND THE INSTRUMENT PANEL

STAGE COMPLETE

