

# STEVE MCQUEEN'S ICONIC **PORSCHE** **917KH**



## **Pack 04**

### BUILD INSTRUCTIONS

**STAGE 21: ADDING THE EXHAUST OUTLETS AND BRACKETS**

**STAGE 22: FITTING THE FIRST DISTRIBUTOR AND ATTACHING THE WIRES**

**STAGE 23: FITTING THE SECOND DISTRIBUTOR AND ATTACHING THE WIRES**

**STAGE 24: BRAKE FLUID TANKS AND WINDSCREEN WASHER RESERVOIR**

**STAGE 25: FIXING THE ENGINE MOUNT TO THE CHASSIS**

**STAGE 26: INSTALLING THE PEDALS AND FOOTREST ON THE CHASSIS**

**STAGE 27: BUILDING THE DASHBOARD FRAME AND FITTING THE LEFT SUSPENSION**

**STAGE 28: INSTALLING THE STEERING WHEEL ON THE DASHBOARD FRAME**

Porsche, the Porsche shield and the distinctive design of Porsche cars are trademarks and trade dress of Porsche AG. Permission granted.

The Gulf trademarks are used under license from Gulf Oil International Ltd.

Personality rights of Steve McQueen are used with permission of Chadwick McQueen and The Terry McQueen Testamentary Trust.

Represented exclusively by Greenlight.

**AGORA**  
MODELS

## Advice from the experts

Spare screws are included with each part. Occasionally, you may be instructed to keep spare or unused screws for a later stage. Keep these spares in a safe place and label them correctly.

Please make sure you don't mix up the screws. They look quite similar, but the threads do vary slightly. Using the wrong screws may damage the parts.

When securing parts together using multiple screws, fit each screw loosely to ensure all the parts are correctly aligned before gently tightening them firmly, but not overtight, in the order in which you placed them.

The screwdriver can be magnetized by stroking it with a magnet (fridge magnet, etc.) enabling it to hold the screws and make assembly easier.

If a screw is tight going into a metal part, do not force it as you may shear the head off. Remove it and put a tiny smear of Vaseline, soap or light oil on the thread. That will lubricate it and make it easier to drive home.

During the course of this build, you will receive many pieces that you will assemble immediately – following the instructions in the corresponding stage – and other pieces that you should store safely to one side, for use in future assembly stages.

Left and Right! When building your Porsche 917KH, the left or right hand side refers to each side as you are sitting in the car.



**WARNING:** Some parts are assembled using magnets. These magnets can cause serious injury if they are swallowed. Keep away from children. If you suspect a magnet has been swallowed, seek medical help straight away.

# STAGE 21: ADDING THE EXHAUST OUTLETS AND BRACKETS

**21A** Upper left exhaust outlet

**21B** Lower left exhaust outlet

**21C** Exhaust outlet bracket (x2)

**21D** Upper right exhaust outlet

**21E** Lower right exhaust outlet

**AP** Screw 1.7 x 4 mm (x3)

**BP** Screw 1.7 x 3 x 5 mm (x3)

**IM** Screw 1.7 x 5 mm (x3)

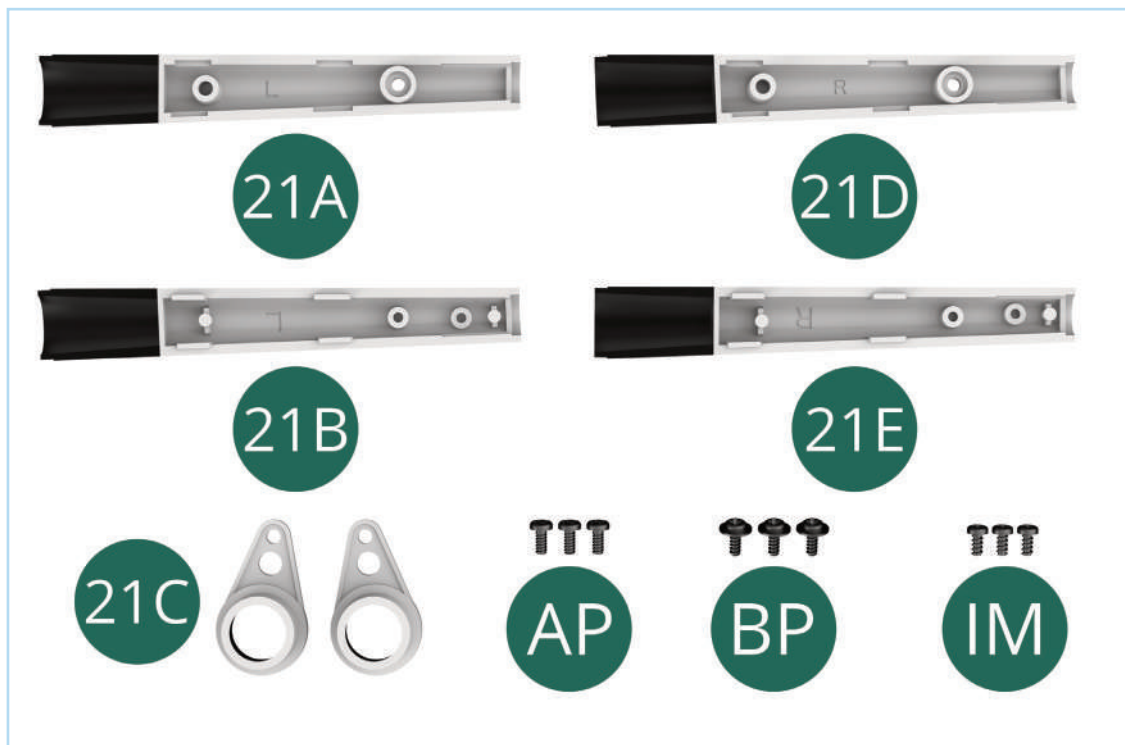

## ASSEMBLY DIAGRAM

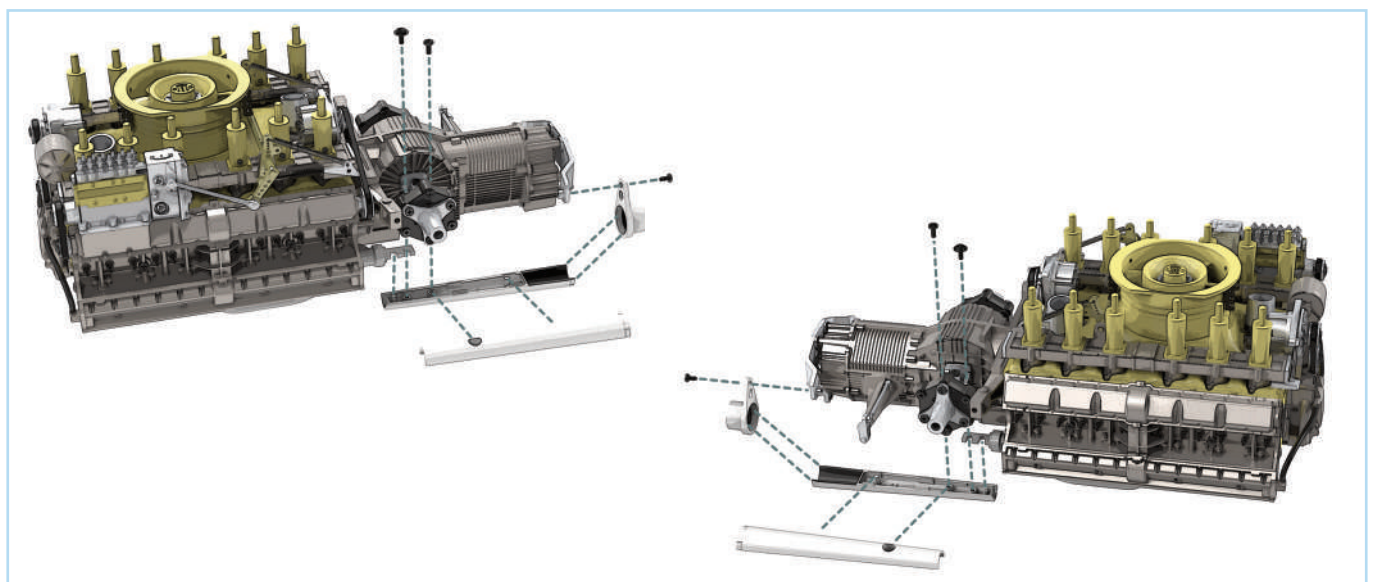

# STAGE 21: ADDING THE EXHAUST OUTLETS AND BRACKETS

## STEP 1

Take the engine assembly. Position the **lower left exhaust outlet (21B)** on the connection at the end of the **exhaust manifold (19H)** as shown. Secure the parts together using a **BP** screw.

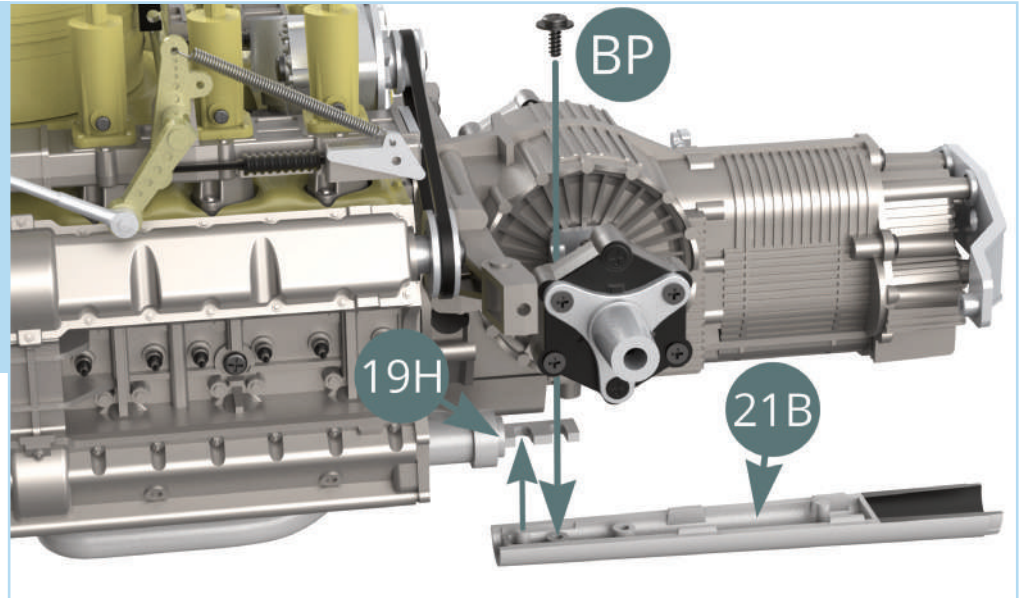

Firmly press the **upper left exhaust outlet (21A)** onto the **lower left exhaust outlet (21B)**. Check the connection is flush along both edges.

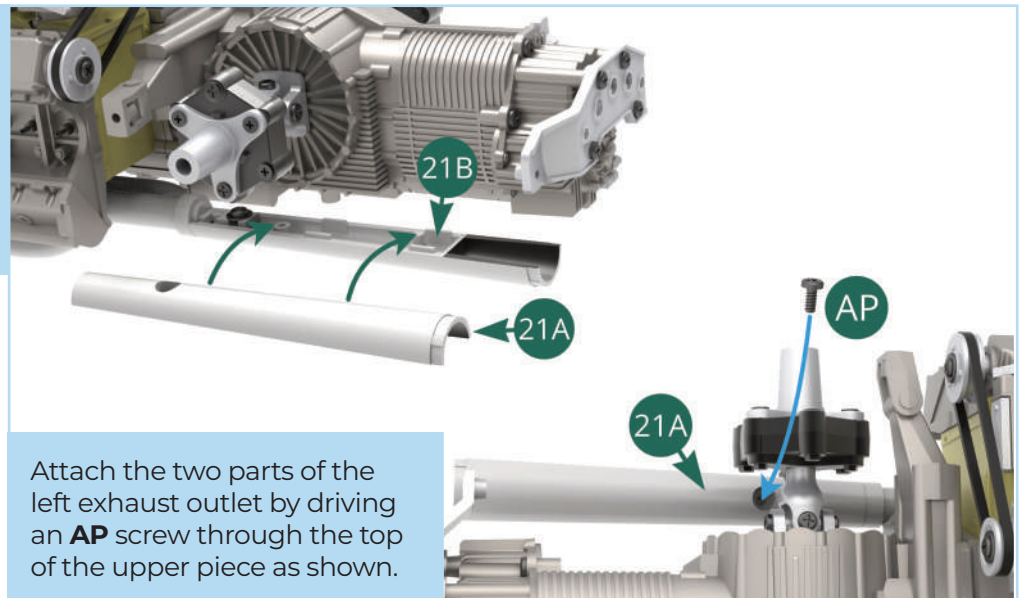

Attach the two parts of the left exhaust outlet by driving an **AP** screw through the top of the upper piece as shown.

Press one of the **exhaust outlet brackets (21C)** over the upper and lower left exhaust outlet (**21A/21B**) and align the screw hole with the **exhaust pipe bracket (5I)**. Secure it in place using an **IM** screw.

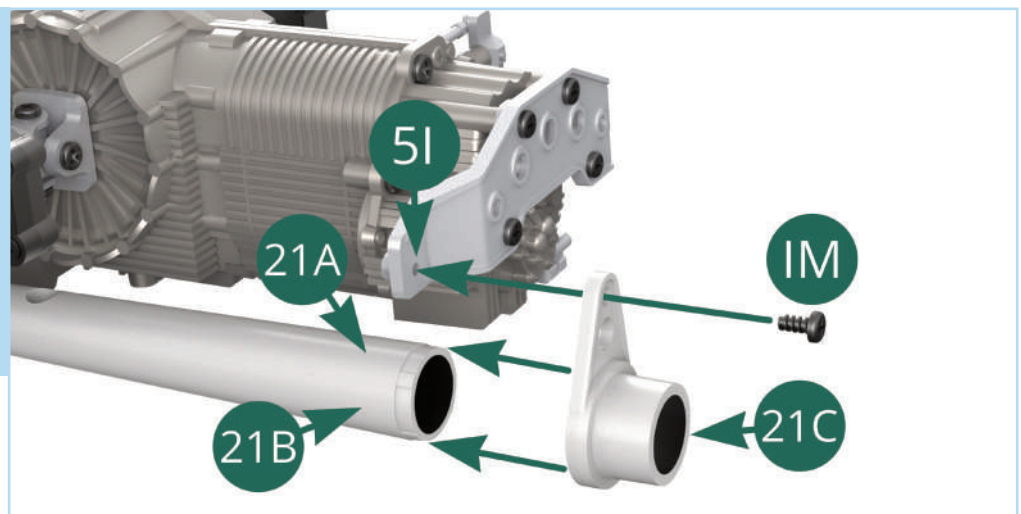



# STAGE 21: ADDING THE EXHAUST OUTLETS AND BRACKETS

## STEP 2

In the same manner, place the **lower right exhaust outlet (21E)** on the connection at the end of the **exhaust manifold (20H)** and fix using a **BP** screw.

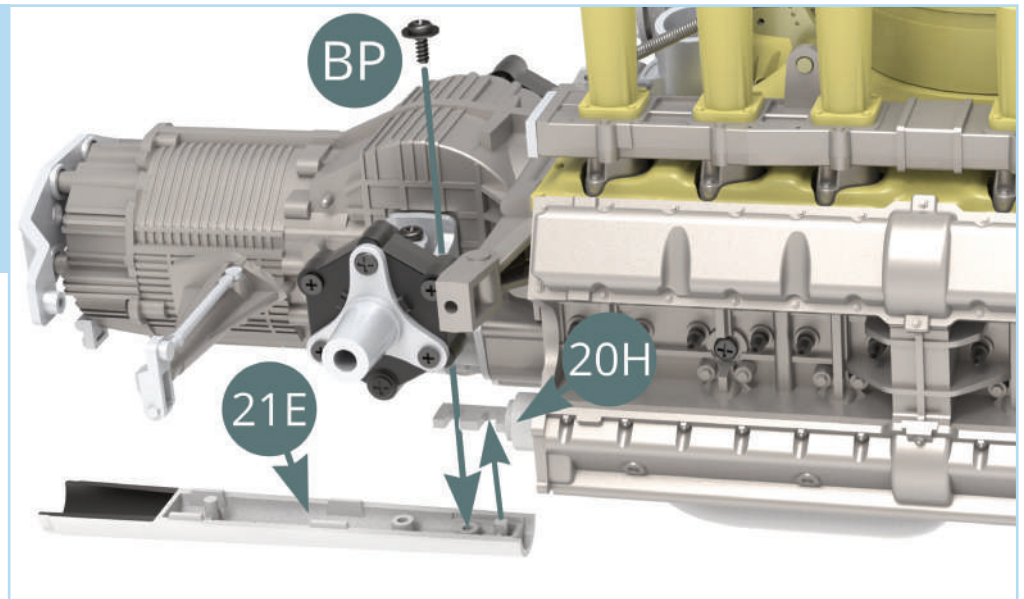

Press the **upper right exhaust outlet (21A)** onto the **lower right exhaust outlet (21B)**. Once in place, secure the parts together using an **AP** screw.

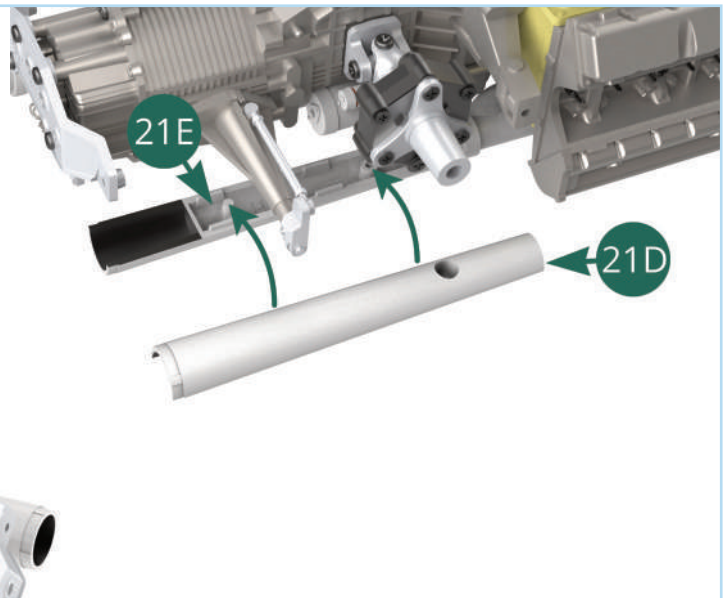
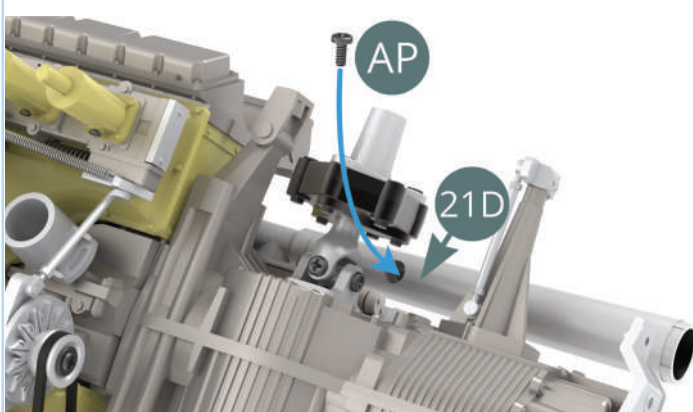

Push the remaining **exhaust outlet bracket (21C)** in position over the upper and lower right exhaust outlet (**21D/21E**) and the **exhaust pipe bracket (5I)**. Secure it in place using an **IM** screw.

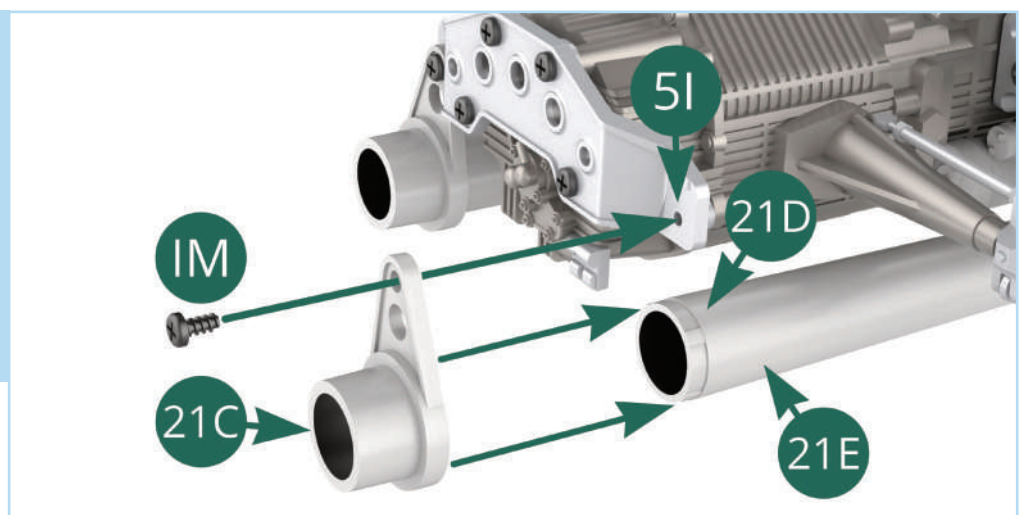

# STAGE 21: ADDING THE EXHAUST OUTLETS AND BRACKETS

STAGE COMPLETE

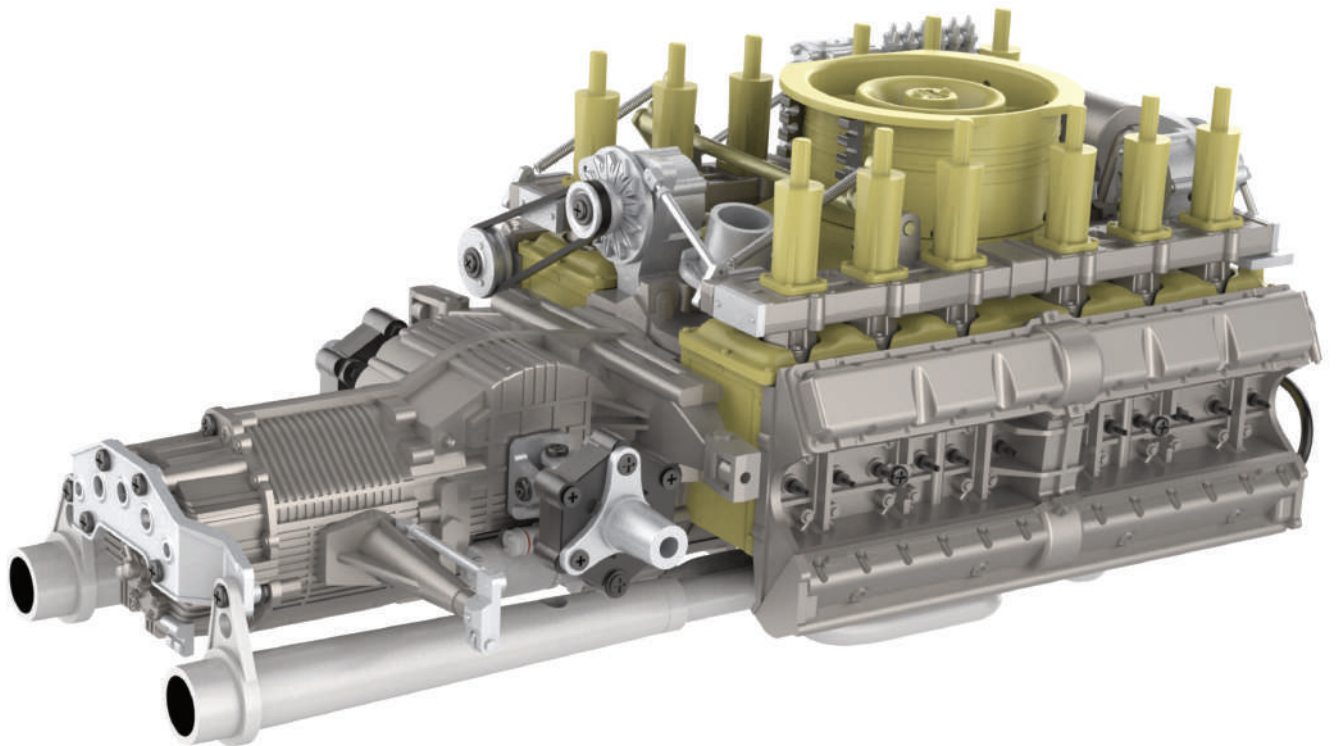
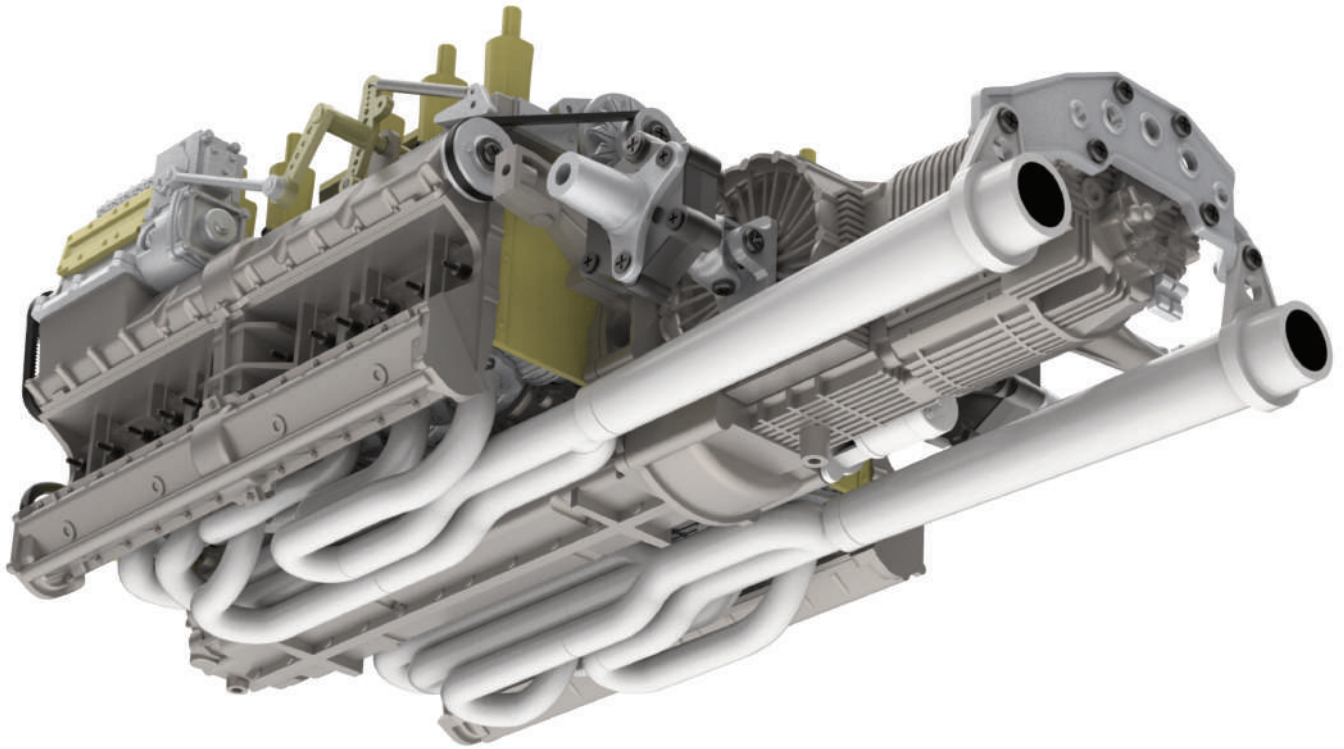



# STAGE 22: FITTING THE FIRST DISTRIBUTOR AND ATTACHING THE WIRES

**22A** Distributor top

**AP** Screw 1.7 x 4 mm (x2)

**22B** Distributor cap

**22C** Plug lead connector (x18)

**22D** Plug lead (x12) – on a roll

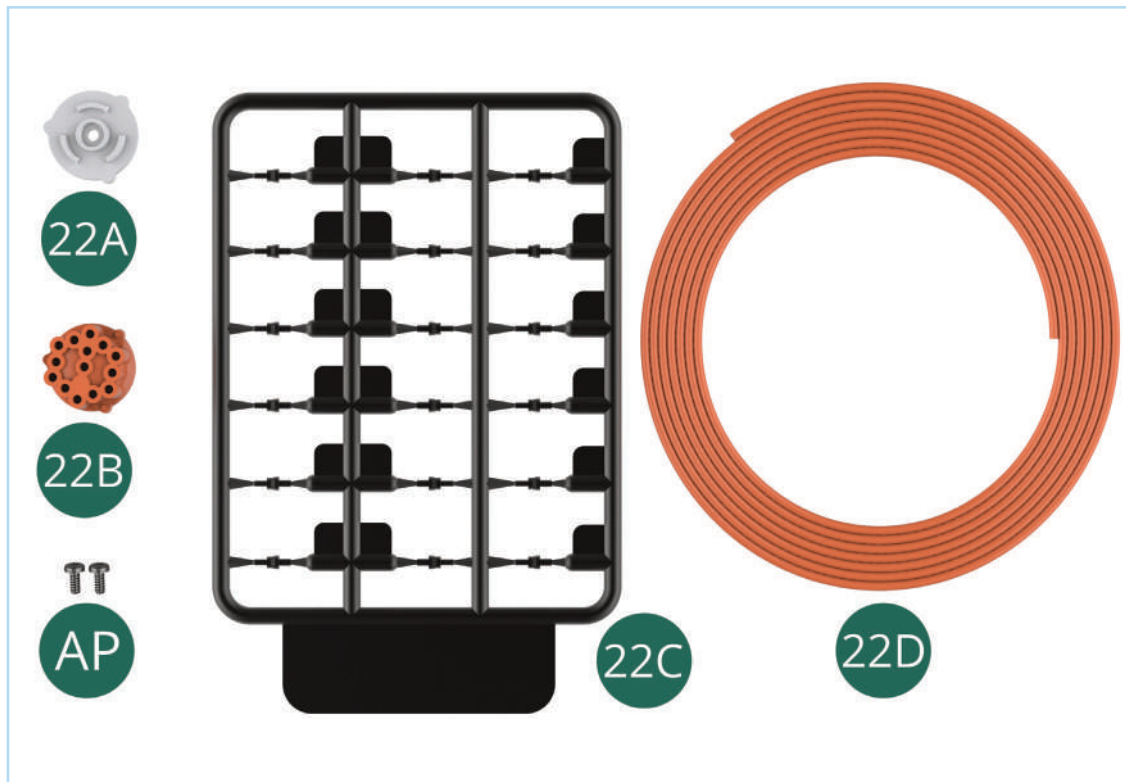

## ASSEMBLY DIAGRAM

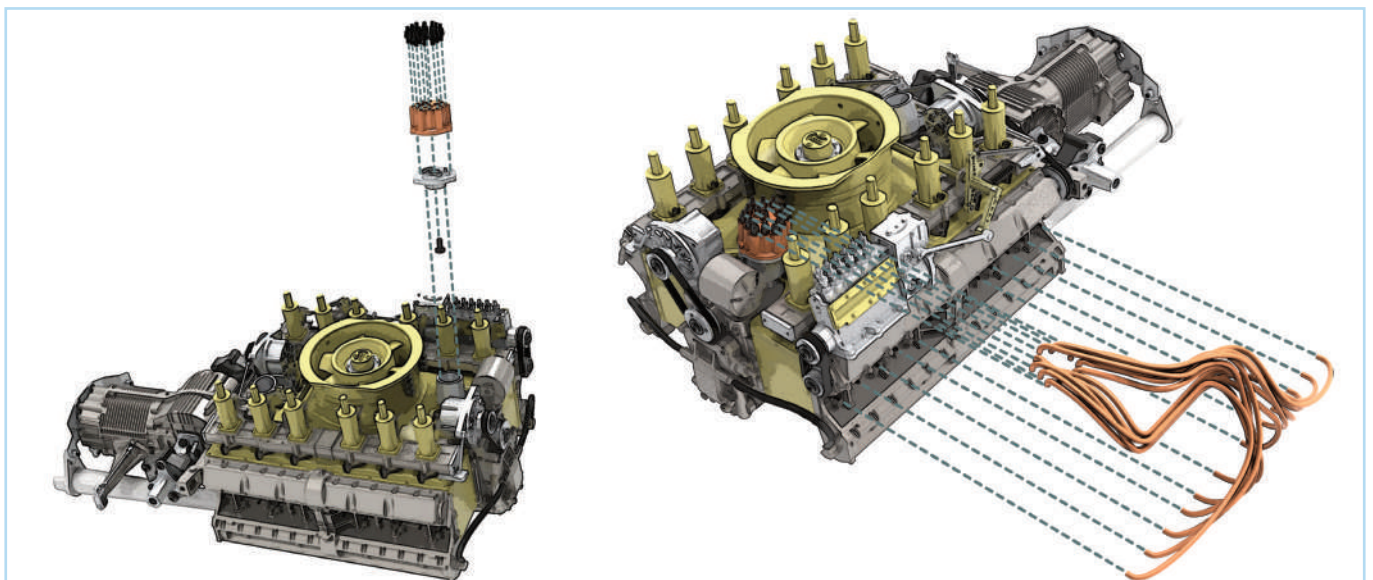

# STAGE 22: FITTING THE FIRST DISTRIBUTOR AND ATTACHING THE WIRES

## STEP 1

Position the **distributor cap (22B)** onto the **distributor top (22A)** and secure using an **AP** screw.

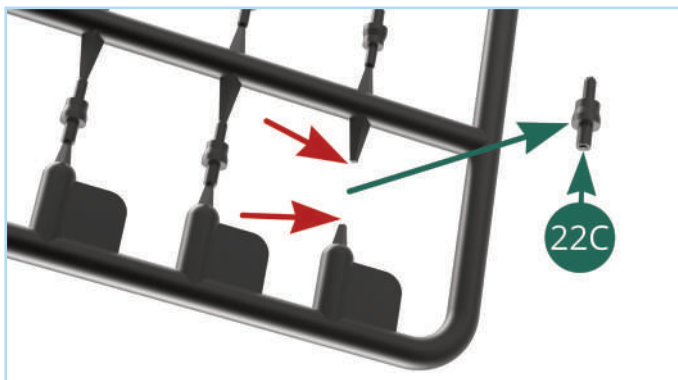
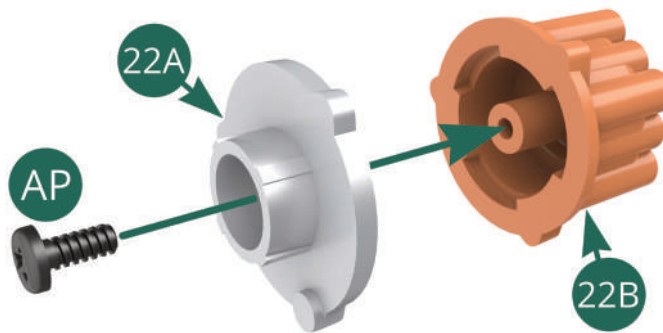

Using sprue cutters, detach 14x **plug lead connectors (22C)** by clipping at the points indicated by the red arrows.

Push the thicker ends of the 14 **plug lead connectors (22C)** into the holes of the **distributor cap (22B)**.

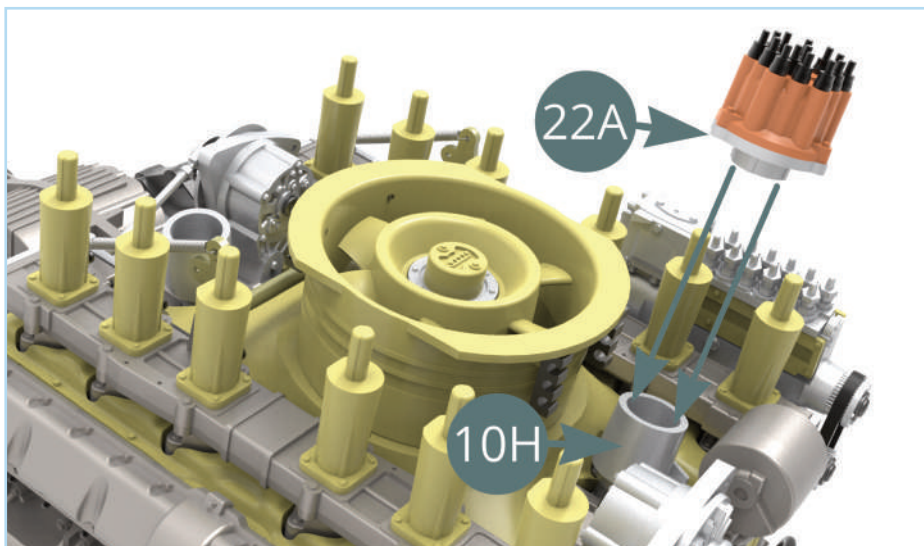
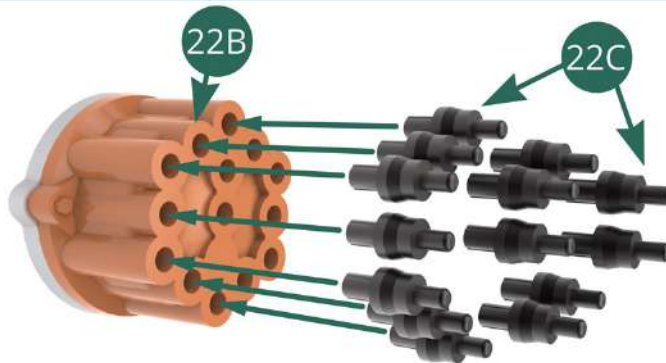

Fit the **distributor top (22A)** onto the **distributor (10H)**. Check its orientation is correct, as shown below.

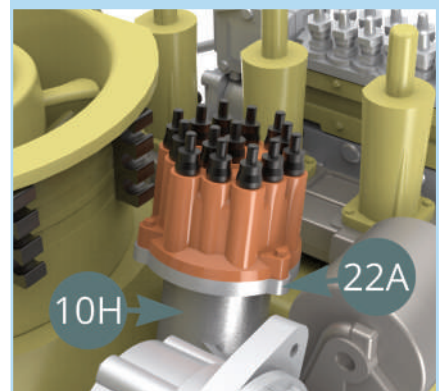



# STAGE 22: FITTING THE FIRST DISTRIBUTOR AND ATTACHING THE WIRES

## STEP 2

Measure and cut 10 cm of plug lead from the **plug lead roll (22D)**.

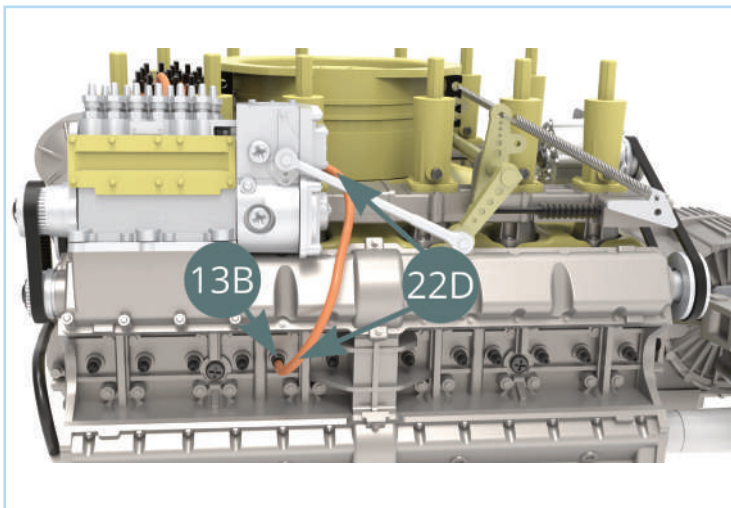
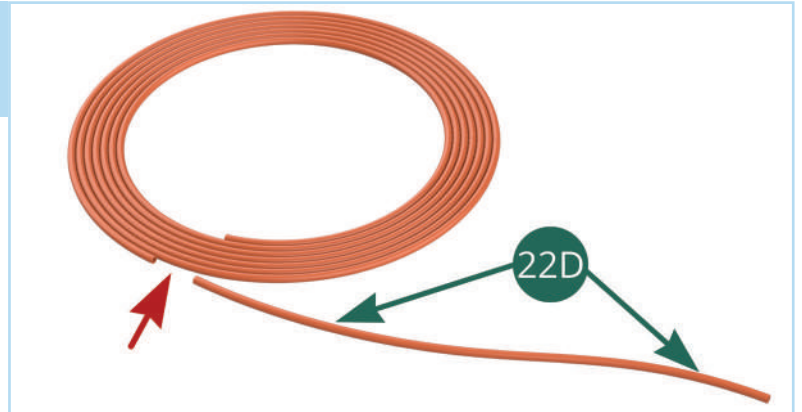

Connect the first 10 cm **plug lead (22D)** to the **spark plug (13B)** and **plug lead connector (22C)** shown below. Turn the distributor into position (blue arrow).

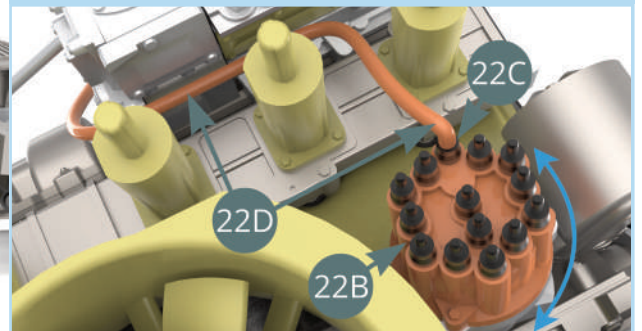

## STEP 3

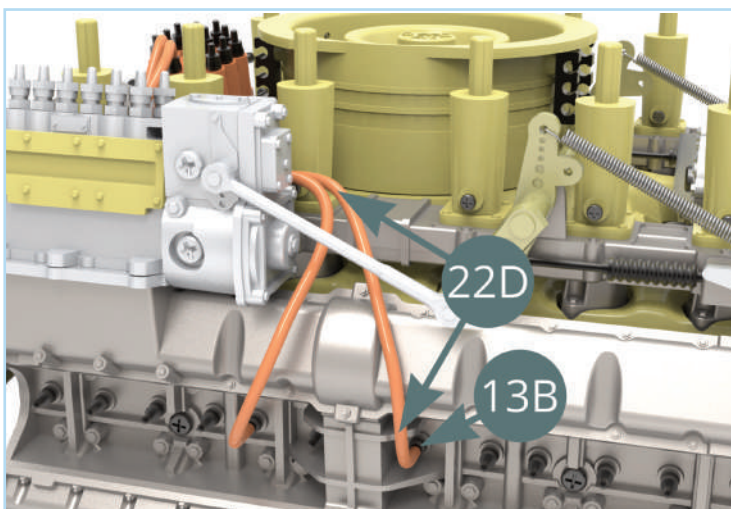

Cut a second **plug lead (22D)** measuring 10 cm in length and attach it to the **spark plug (13B)** and **plug lead connector (22C)** as shown.

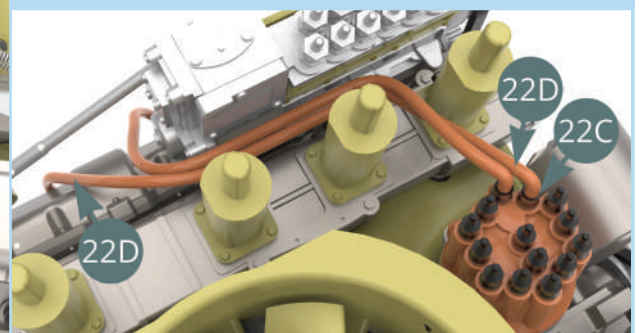

# STAGE 22: FITTING THE FIRST DISTRIBUTOR AND ATTACHING THE WIRES

## STEP 4

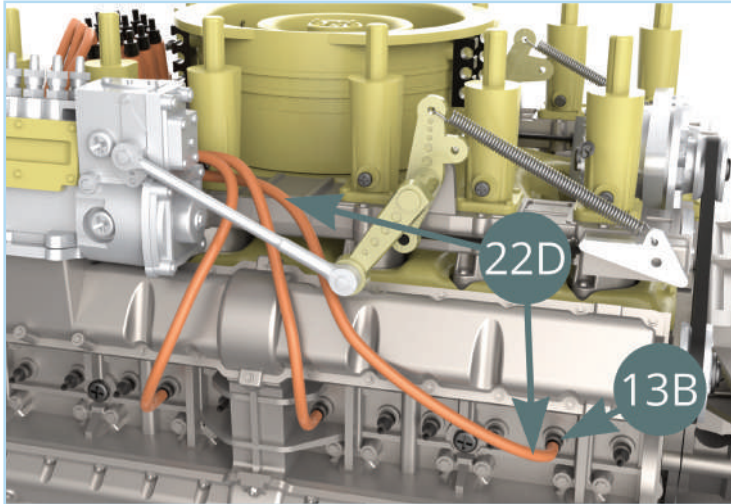

Next cut the third **plug lead (22D)** 12 cm in length and attach it to the **spark plug (13B)** and **plug lead connector (22C)** as shown.

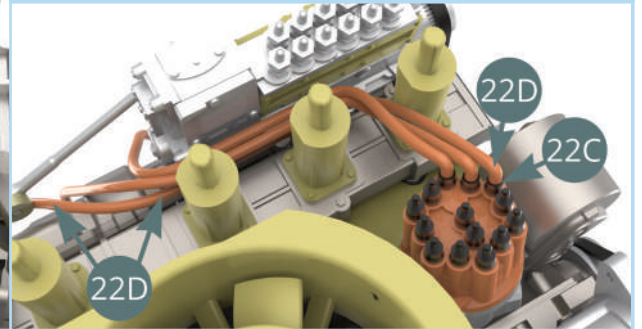

## STEP 5

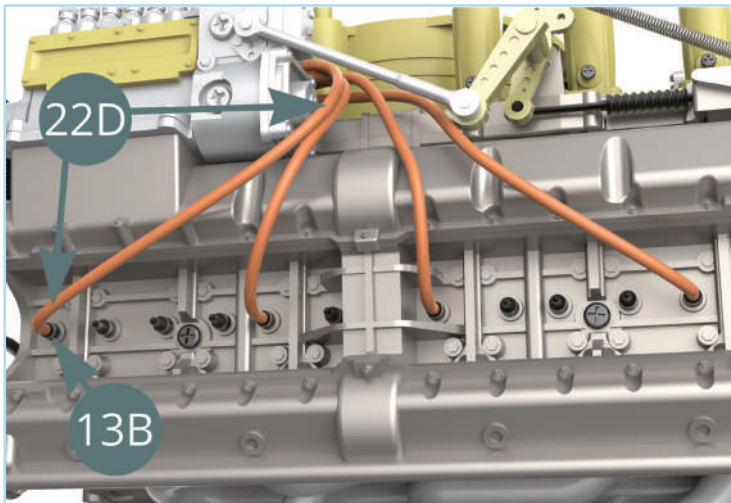

The fourth **plug lead (22D)** is 12.5 cm in length. Attach it to the leftmost **spark plug (13B)** and next **plug lead connector (22C)** in sequence.

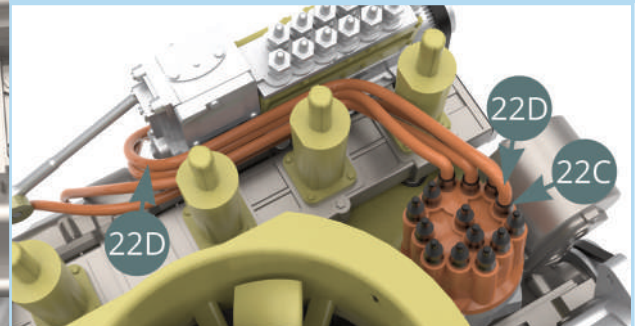

## STEP 6

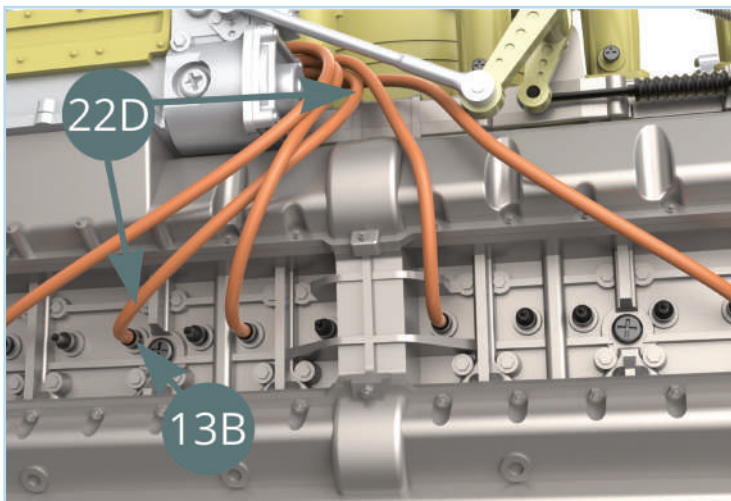

Cut the fifth **plug lead (22D)** measuring 12 cm in length and attach it to the **spark plug (13B)** and **plug lead connector (22C)** as shown.

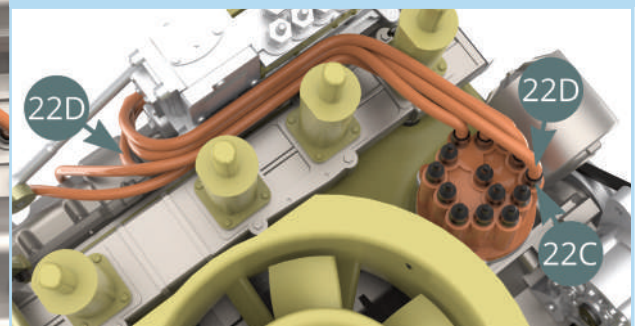



# STAGE 22: FITTING THE FIRST DISTRIBUTOR AND ATTACHING THE WIRES

## STEP 7

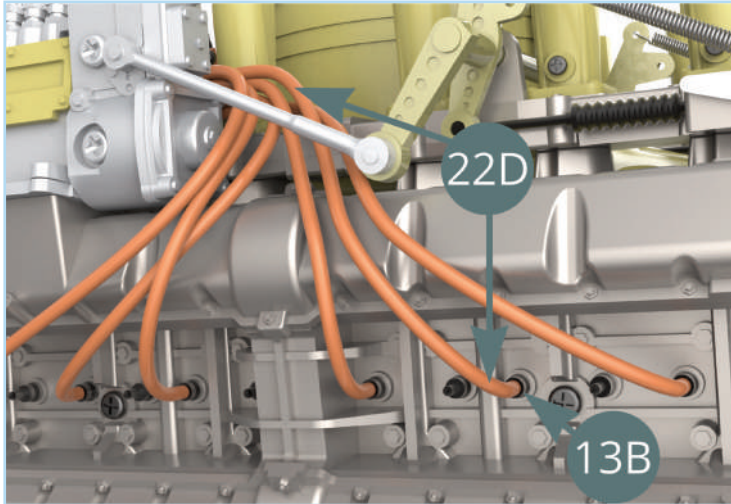

Now cut a sixth **plug lead (22D)** 12 cm in length and attach it to the **spark plug (13B)** and **plug lead connector (22C)** as shown.

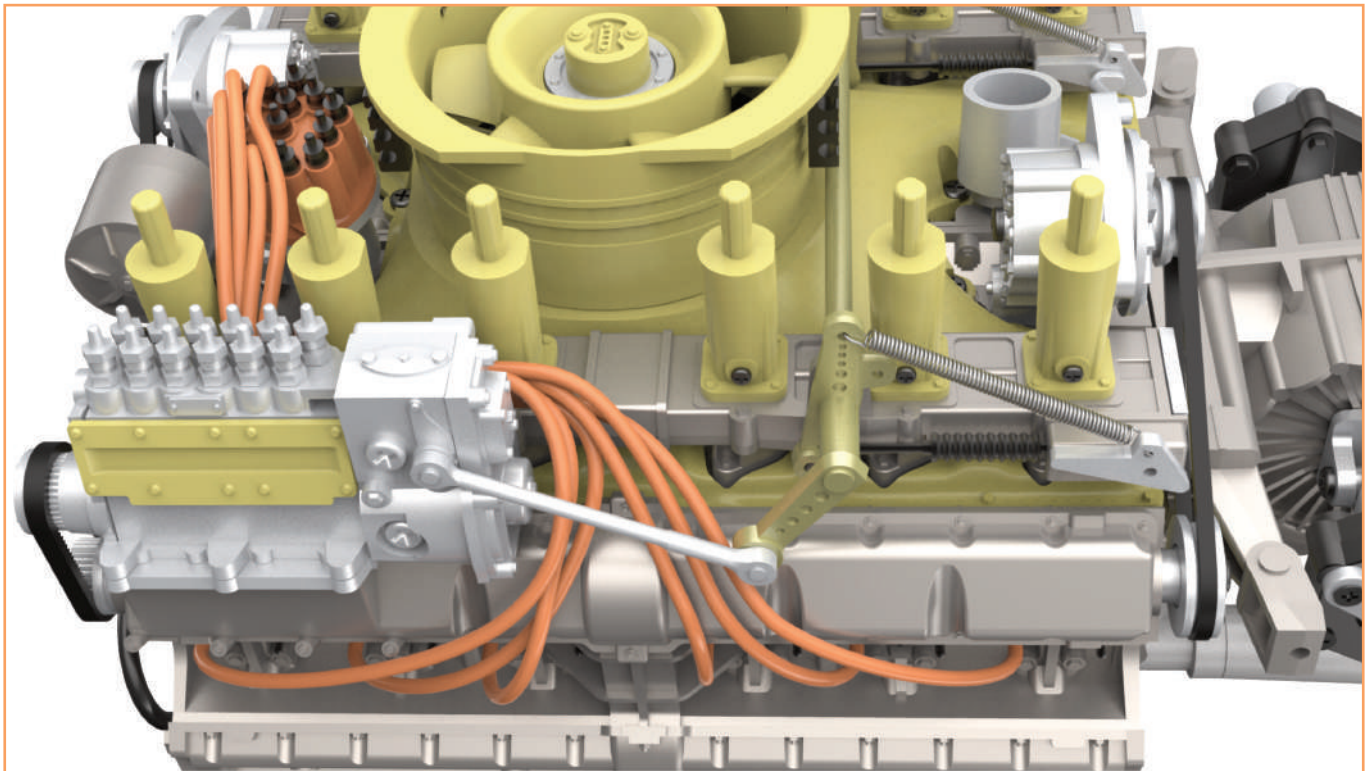
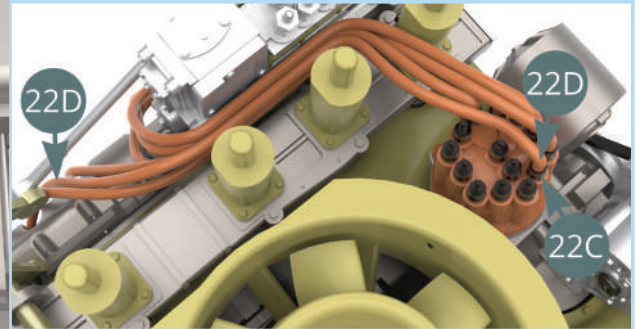

The first six plug leads have been fitted onto the engine. Next you'll attach six more onto the remaining spark plugs and connectors.



# STAGE 22: FITTING THE FIRST DISTRIBUTOR AND ATTACHING THE WIRES

## STEP 8

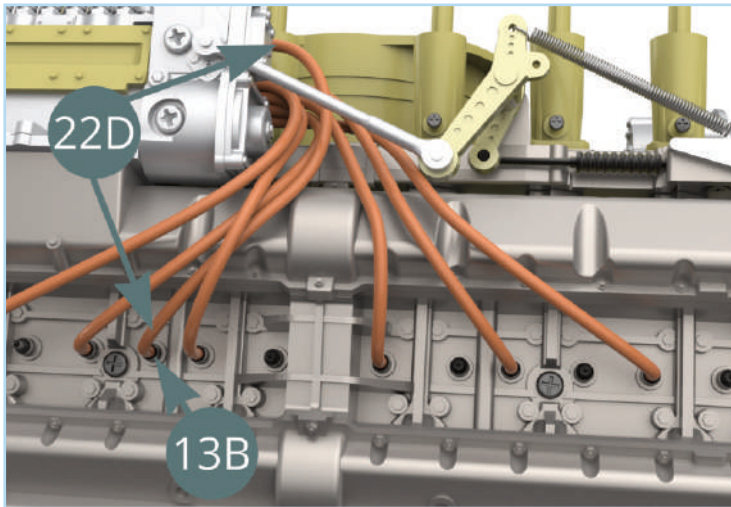

The seventh **plug lead (22D)** is 10 cm long. Cut and then attach it to the **spark plug (13B)** and **plug lead connector (22C)** as shown.

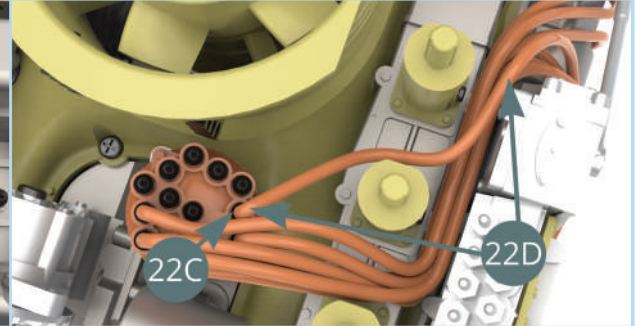

## STEP 9

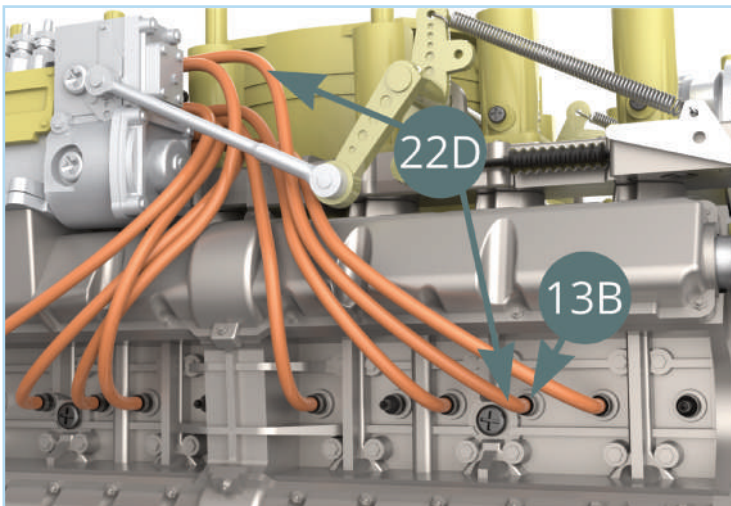

For the eighth **plug lead (22D)** cut off 10.5 cm then attach it to the **spark plug (13B)** and **plug lead connector (22C)** as shown.

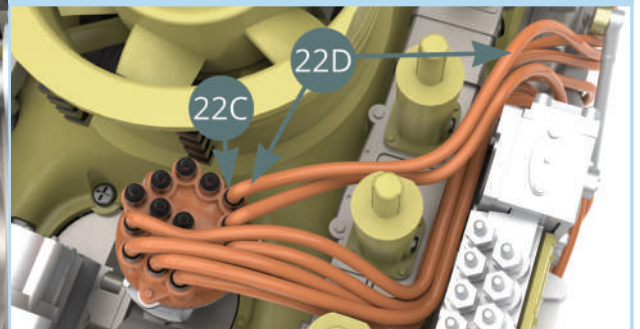

## STEP 10

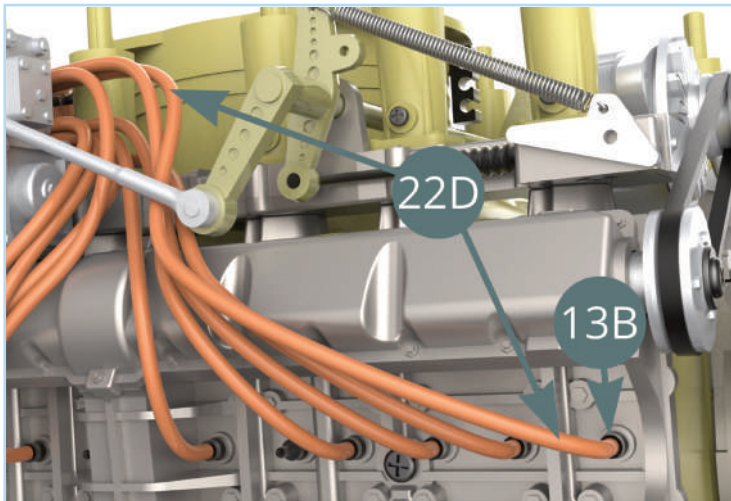

Cut 12 cm for the ninth **plug lead (22D)** then attach it to the **spark plug (13B)** at the end and next **plug lead connector (22C)** in sequence.

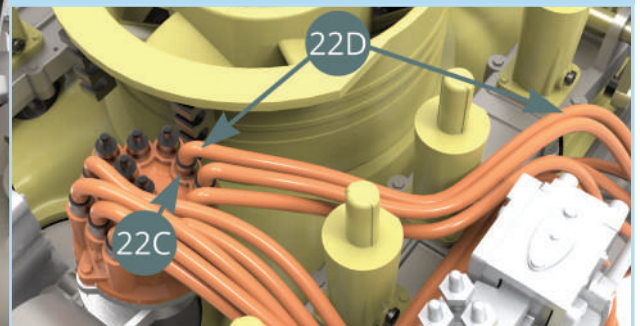



# STAGE 22: FITTING THE FIRST DISTRIBUTOR AND ATTACHING THE WIRES

## STEP 11

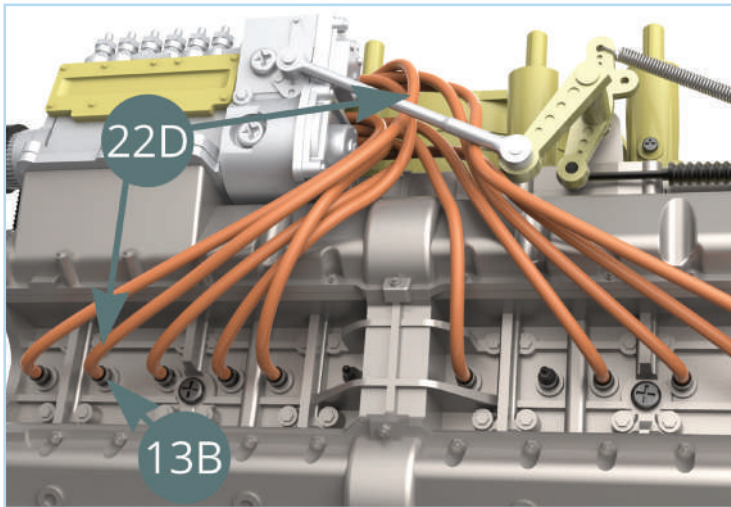

The tenth **plug lead (22D)** is 11.5 cm long. Cut and then attach it to the **spark plug (13B)** and **plug lead connector (22C)** as shown.

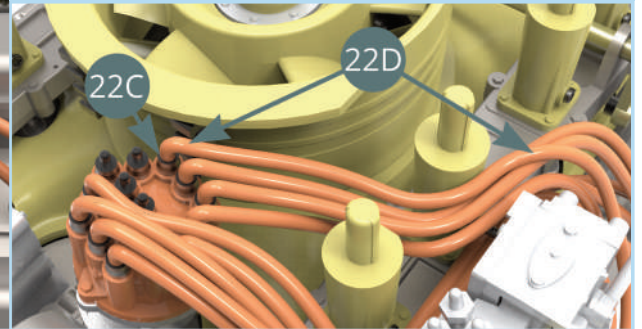

## STEP 12

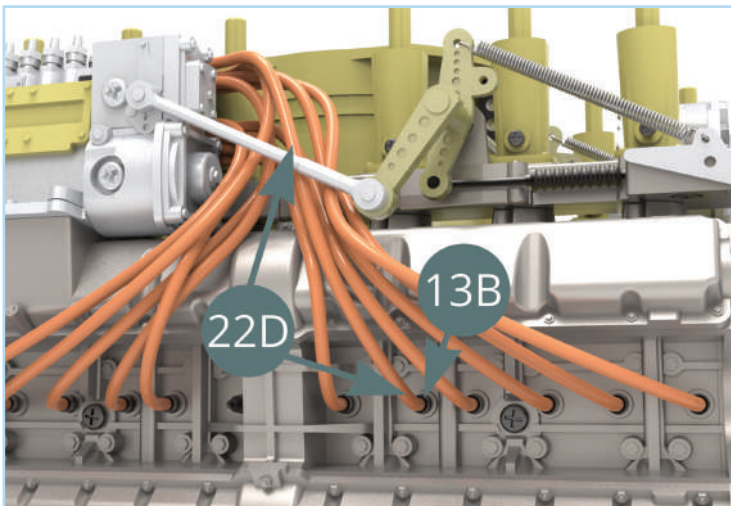

For the eleventh **plug lead (22D)** cut 10.5 cm in length. Attach it to the **spark plug (13B)** and **plug lead connector (22C)** as shown.

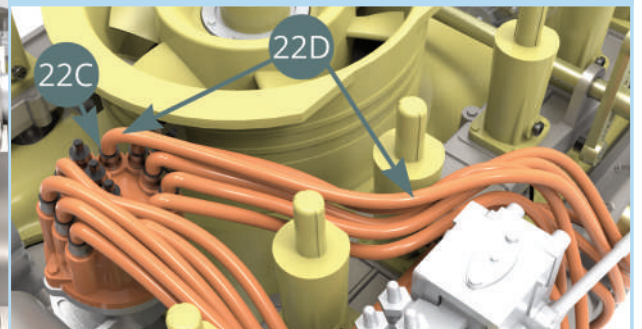

## STEP 13

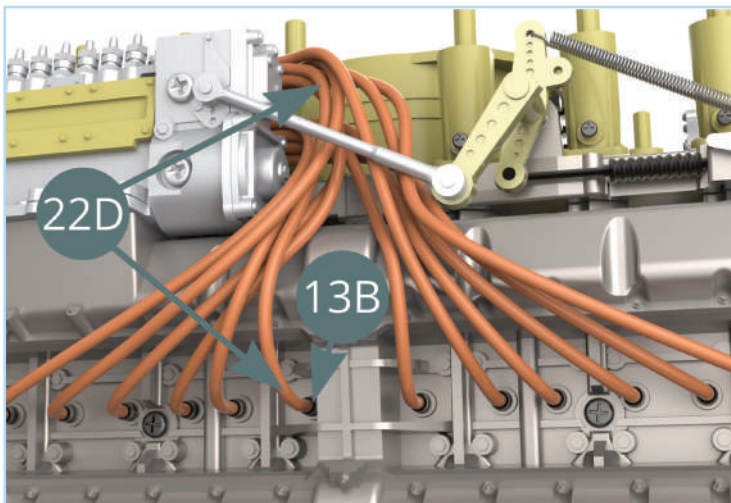

The twelfth **plug lead (22D)** is 10.5 cm in length. Attach it to the final **spark plug (13B)** and **plug lead connector (22C)**, leaving two connectors in the middle.

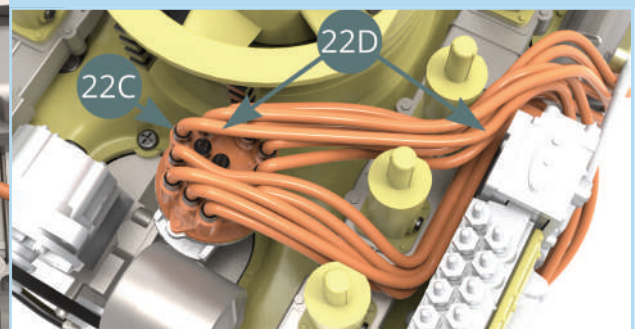



# STAGE 22: FITTING THE FIRST DISTRIBUTOR AND ATTACHING THE WIRES

STAGE COMPLETE

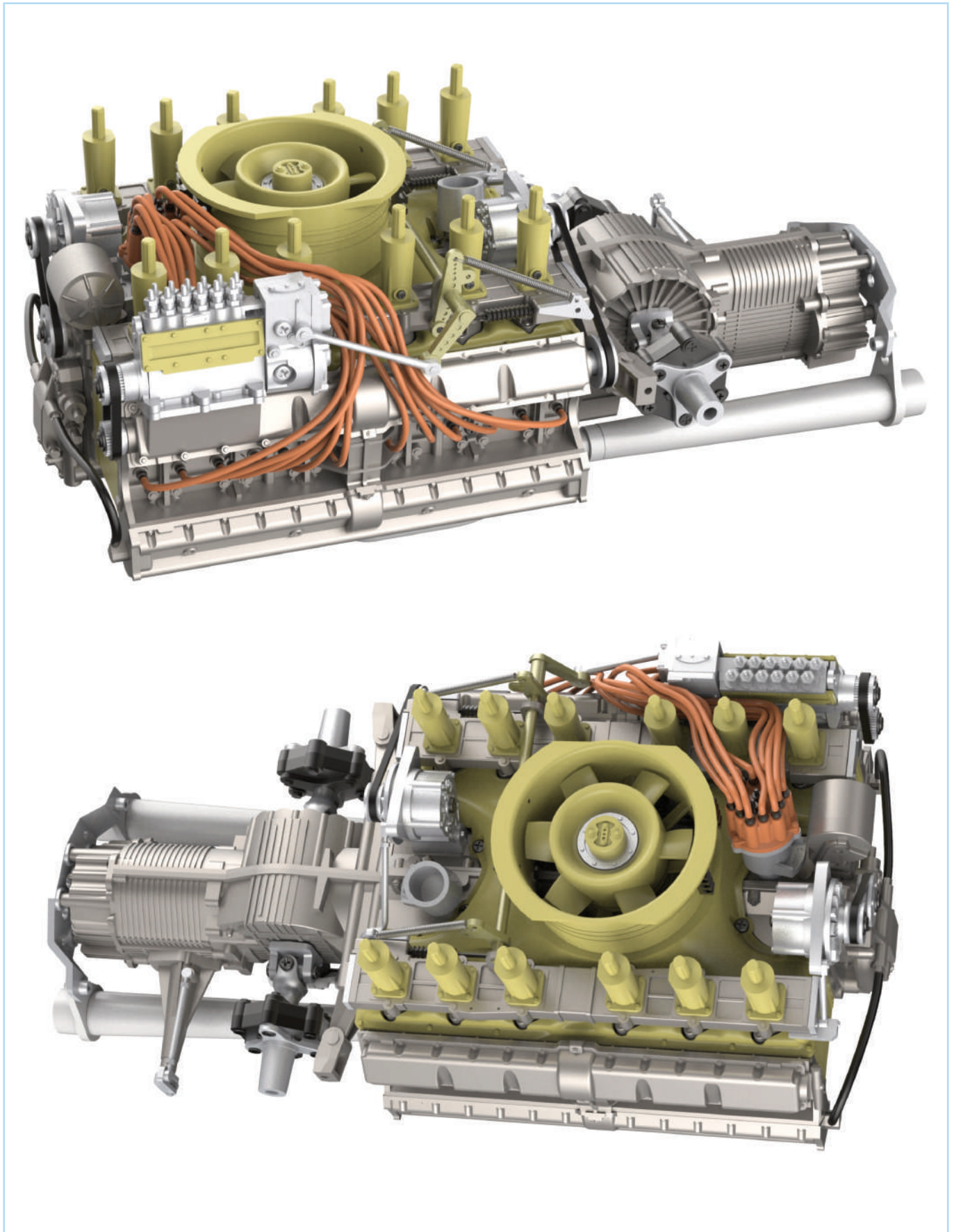

# STAGE 23: FITTING THE SECOND DISTRIBUTOR AND ATTACHING THE WIRES

**23A** Distributor top

**AP** Screw 1.7 x 4 mm (x2)

**23B** Distributor cap

**23C** Plug lead connector (x17)

**23D** Plug lead (x12) – on a roll

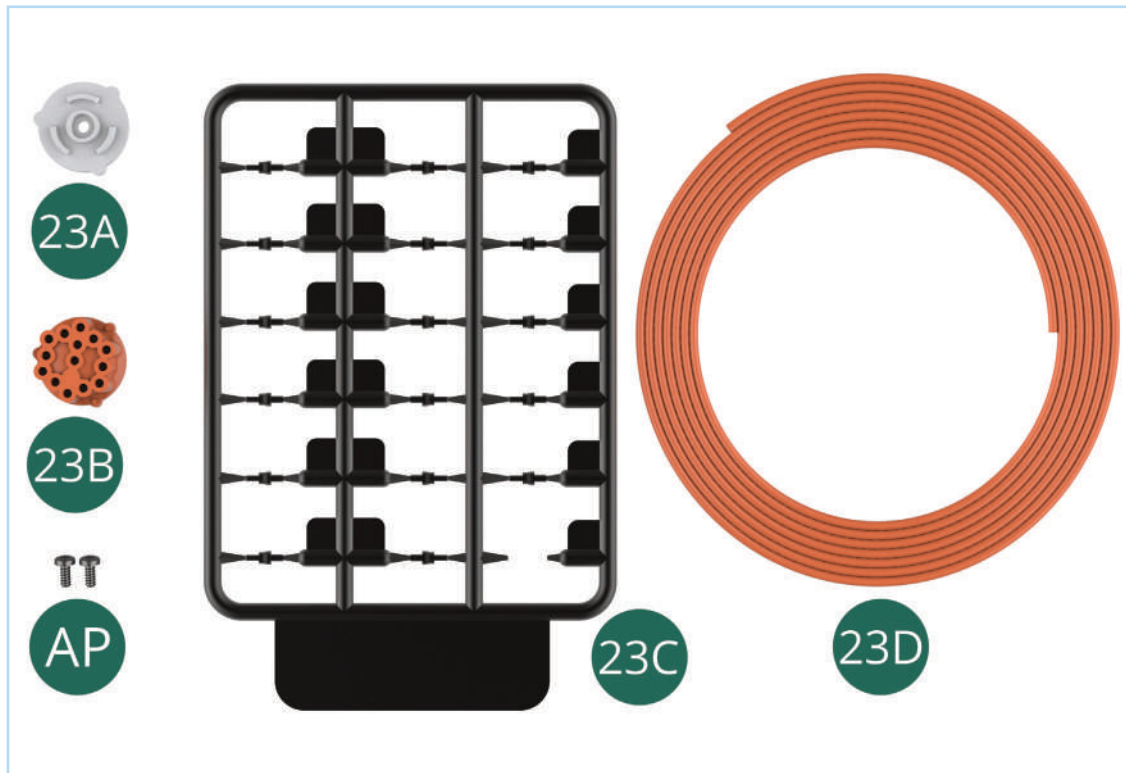

## ASSEMBLY DIAGRAM

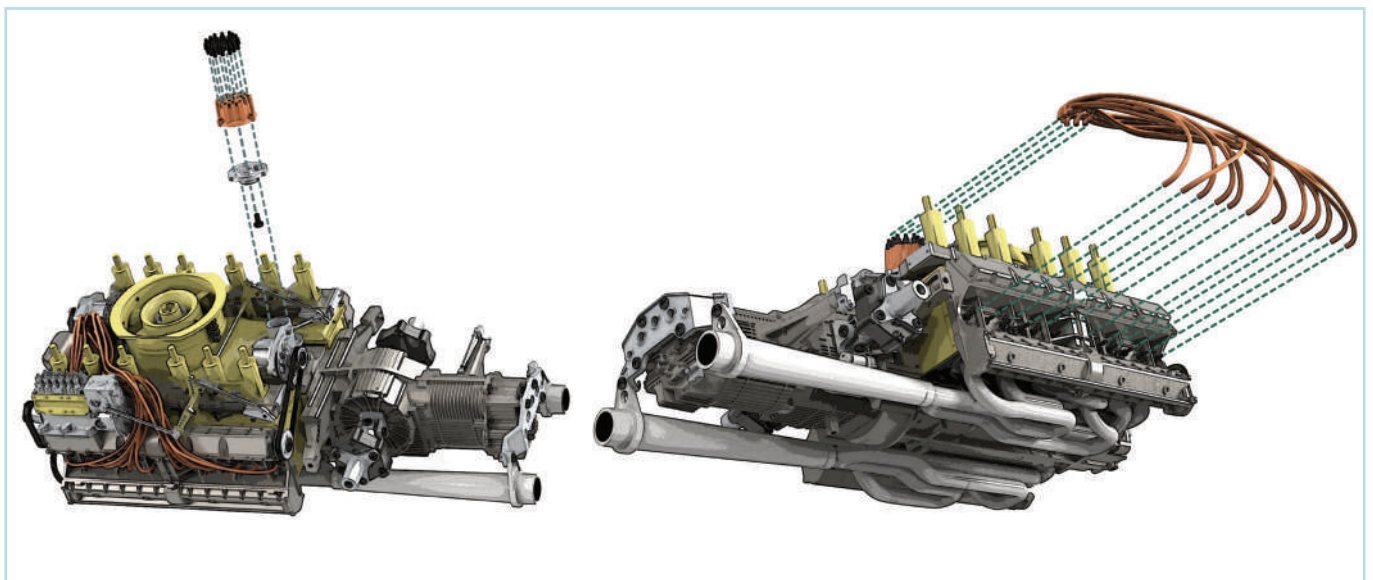



# STAGE 23: FITTING THE SECOND DISTRIBUTOR AND ATTACHING THE WIRES

## STEP 1

Position the **distributor cap (23B)** onto the **distributor top (23A)** and secure using an **AP** screw.

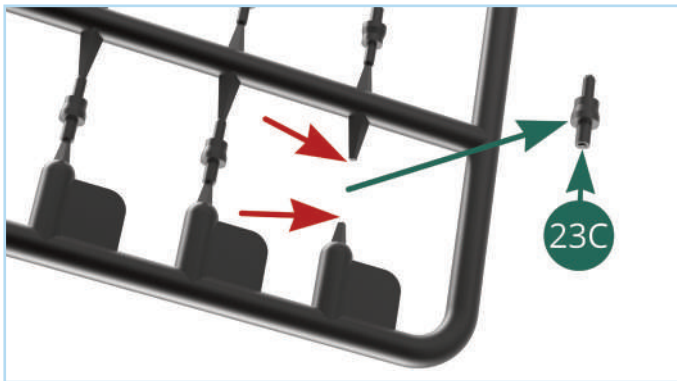
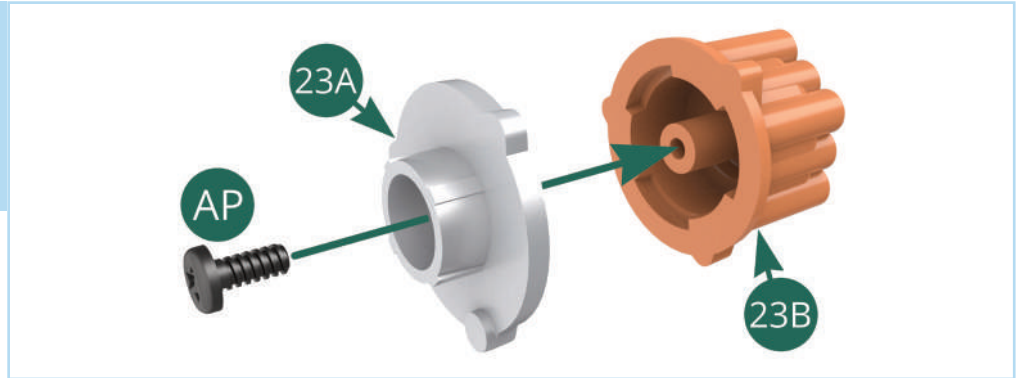

Using sprue cutters, detach 14x **plug lead connectors (23C)** by clipping at the points indicated by the red arrows.

Push the thicker ends of the 14 **plug lead connectors (23C)** into the holes of the **distributor cap (23B)**.

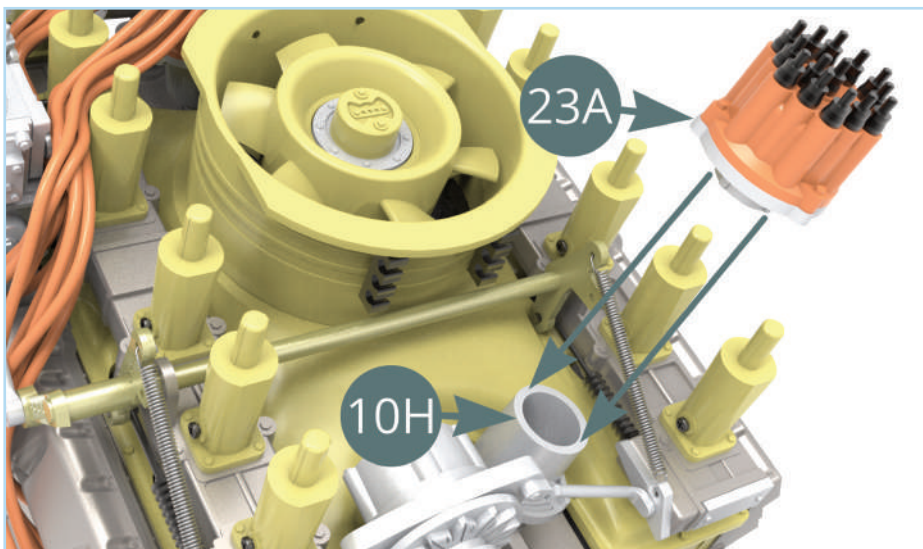
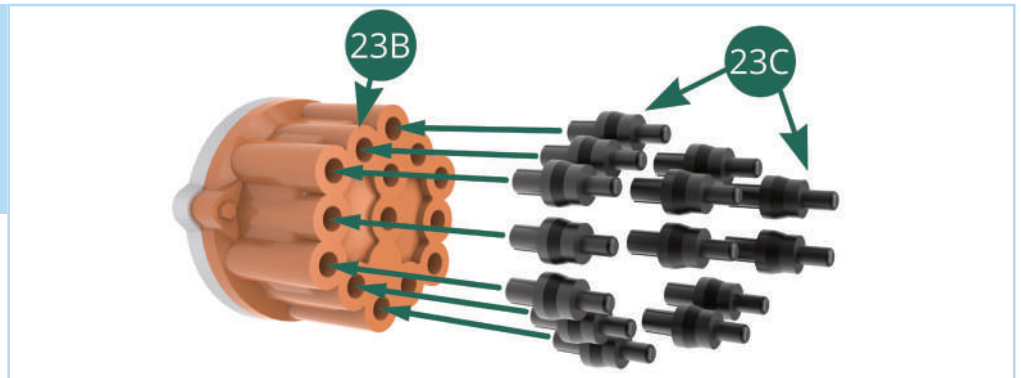

Fit the **distributor top (23A)** onto the **distributor (10H)**. Check its orientation is correct, as shown below.

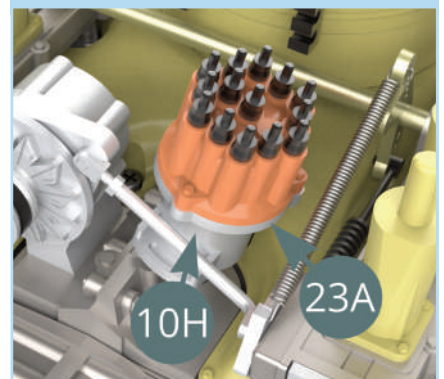



# STAGE 23: FITTING THE SECOND DISTRIBUTOR AND ATTACHING THE WIRES

## STEP 2

Measure and cut 7.5 cm of plug lead from the **plug lead roll (22D)**.

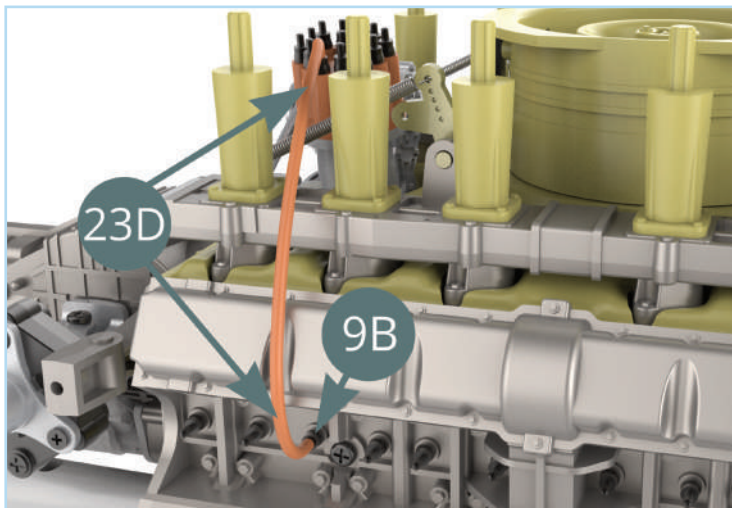
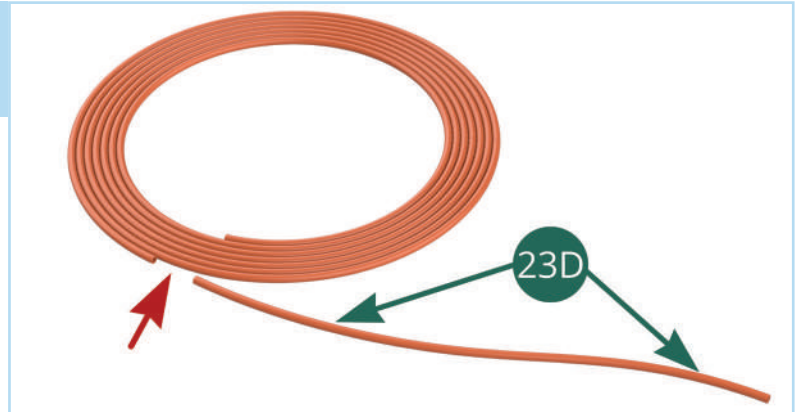

Connect the first 7.5 cm **plug lead (23D)** to the **spark plug (9B)** and **plug lead connector (23C)** as shown. Turn the distributor into position (blue arrow).

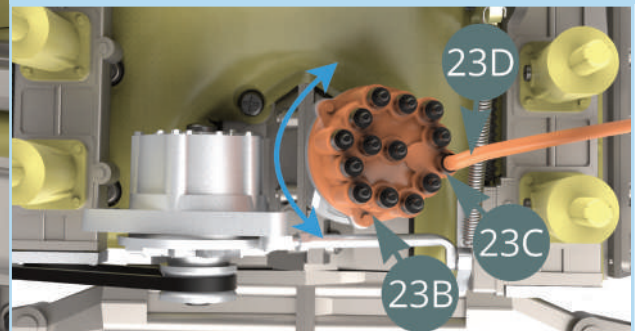

## STEP 3

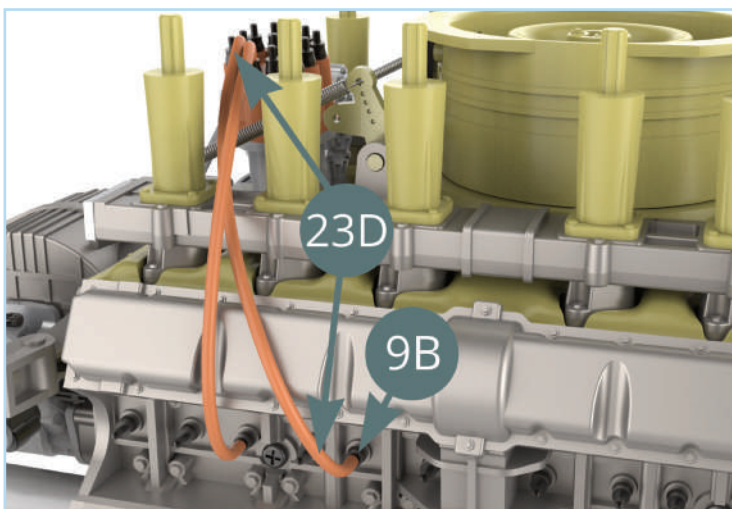

Cut a second **plug lead (23D)** measuring 8.5 cm in length and attach it to the **spark plug (9B)** and **plug lead connector (23C)** as shown.

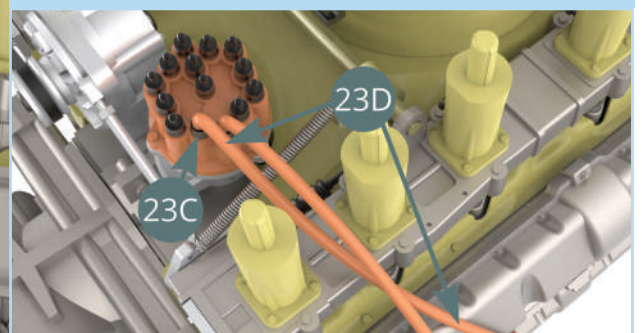

# STAGE 23: FITTING THE SECOND DISTRIBUTOR AND ATTACHING THE WIRES

## STEP 4

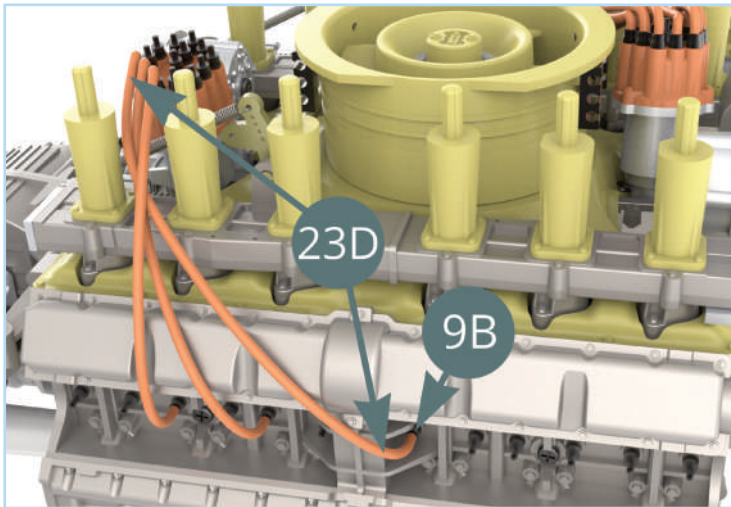

Next cut the third **plug lead (23D)** 10 cm in length and attach it to the **spark plug (9B)** and **plug lead connector (23C)** shown.

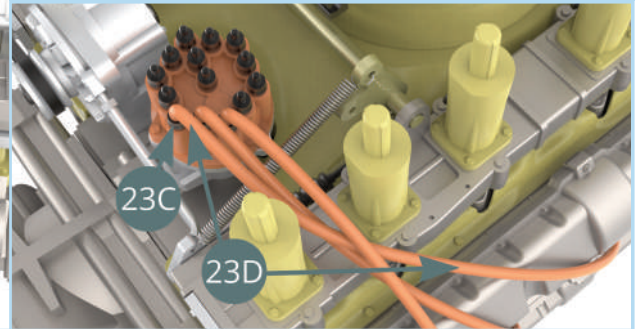

## STEP 5

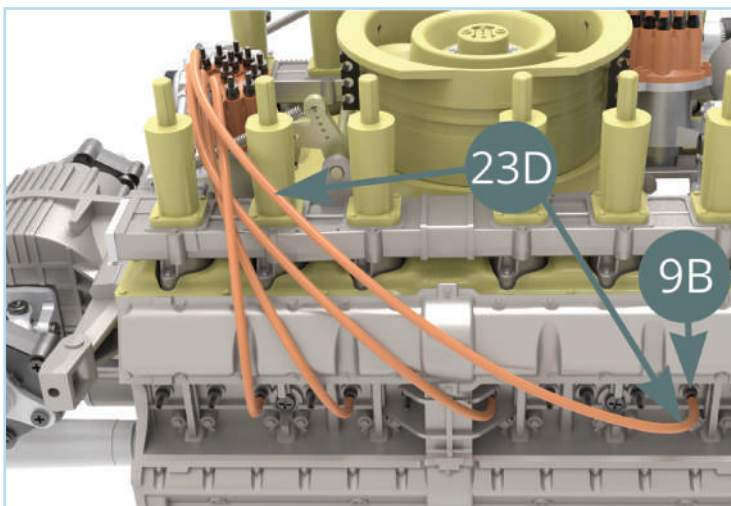

The fourth **plug lead (23D)** is 12 cm in length. Attach it to the **spark plug (9B)** shown and next **plug lead connector (23C)** in sequence.

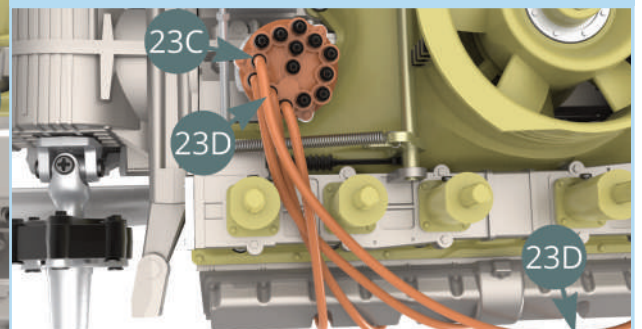

## STEP 6

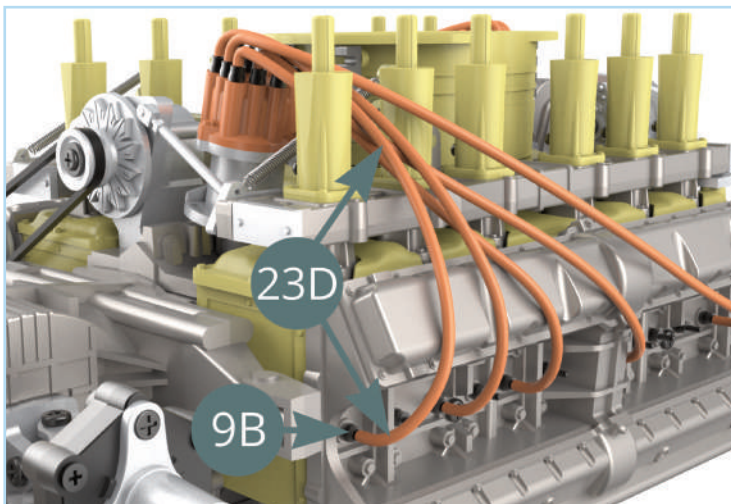

Cut the fifth **plug lead (23D)** measuring 8.5 cm in length and attach it to the **spark plug (9B)** at the end and **plug lead connector (23C)** shown.

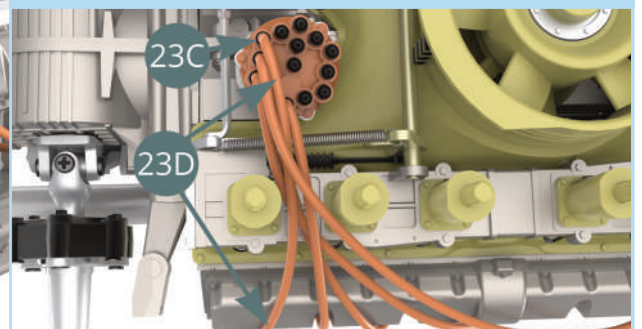



# STAGE 23: FITTING THE SECOND DISTRIBUTOR AND ATTACHING THE WIRES

## STEP 7

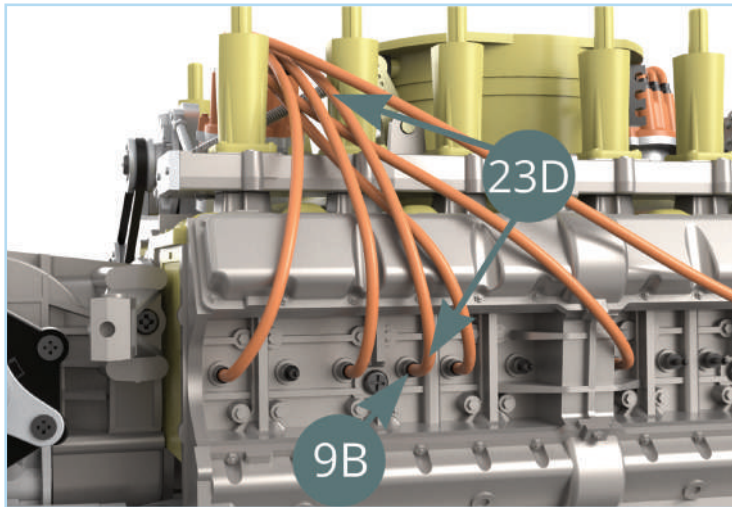

Now cut a sixth **plug lead (23D)** 9 cm in length and attach it to the **spark plug (9B)** and **plug lead connector (23C)** shown.

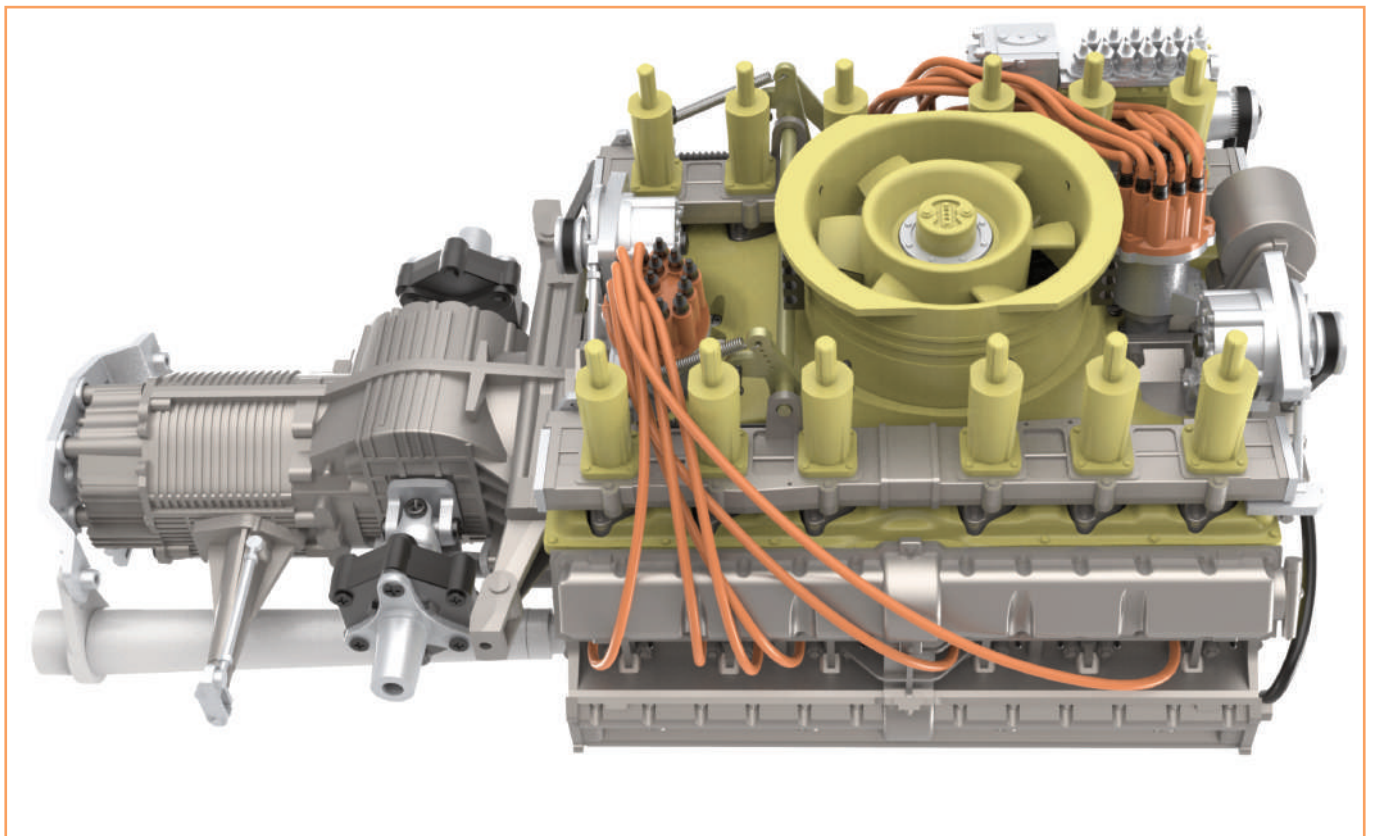
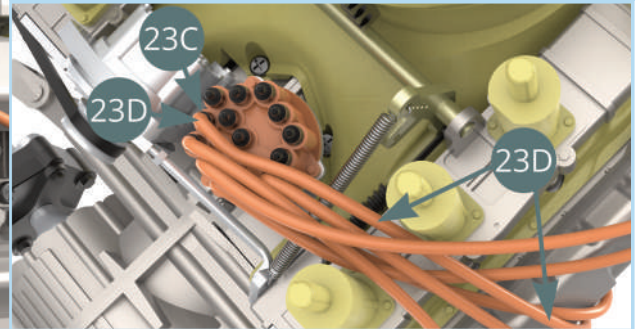

The first six plug leads for the second distributor have been fitted onto the engine. Next you'll attach six more onto the remaining spark plugs and connectors.

# STAGE 23: FITTING THE SECOND DISTRIBUTOR AND ATTACHING THE WIRES

## STEP 8

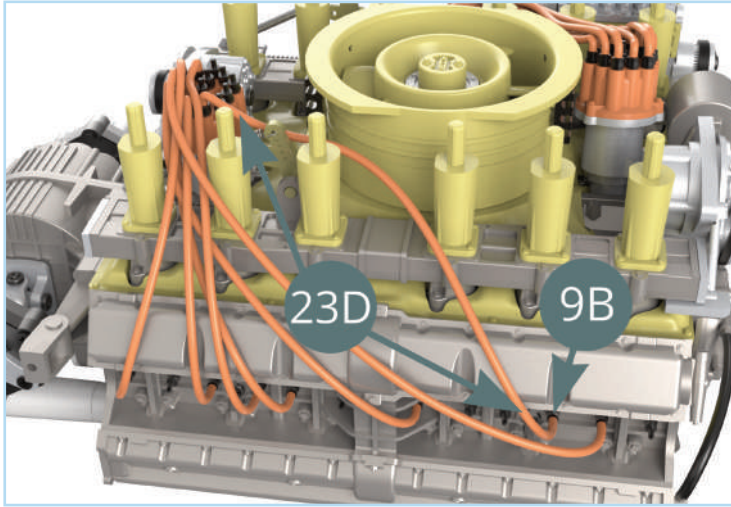

The seventh **plug lead (23D)** is 10.5 cm long. Cut and then attach it to the **spark plug (9B)** and **plug lead connector (23C)** shown.

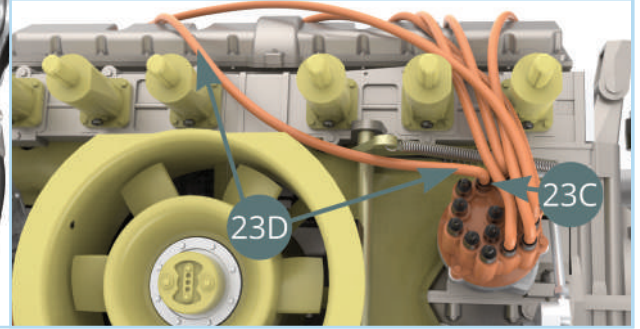

## STEP 9

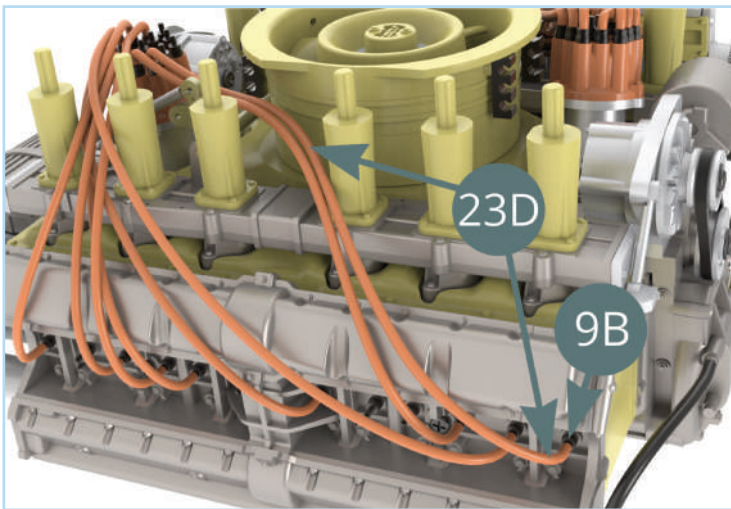

For the eighth **plug lead (23D)** cut off 11.5 cm then attach it to the **spark plug (9B)** at the end and **plug lead connector (23C)** shown.

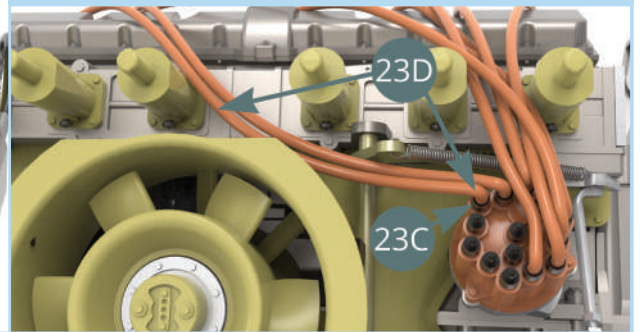

## STEP 10

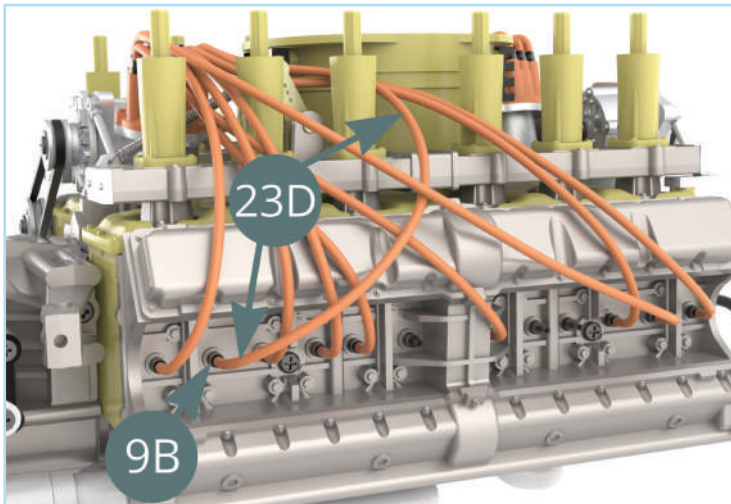

Cut 10.5 cm for the ninth **plug lead (23D)** then attach it to the **spark plug (9B)** and next **plug lead connector (23C)** in sequence.

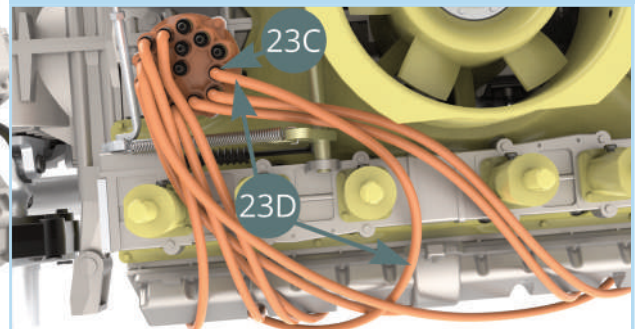



# STAGE 23: FITTING THE SECOND DISTRIBUTOR AND ATTACHING THE WIRES

## STEP 11

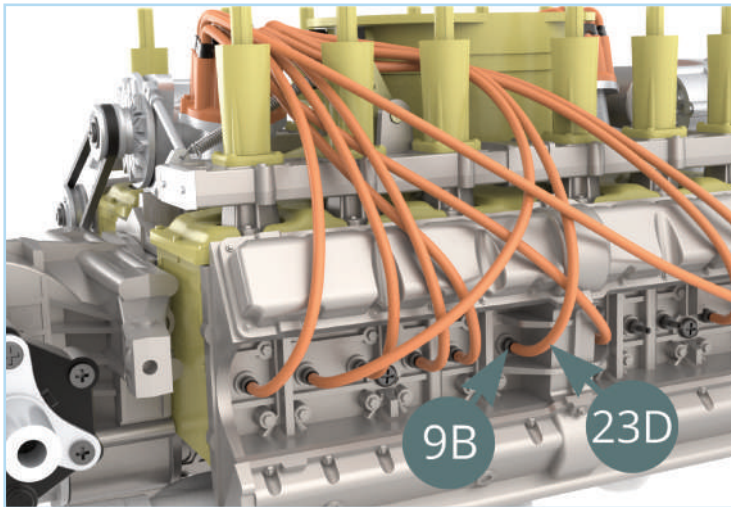

The tenth **plug lead (23D)** is 9.5 cm long. Cut and then attach it to the **spark plug (9B)** and **plug lead connector (23C)** shown.

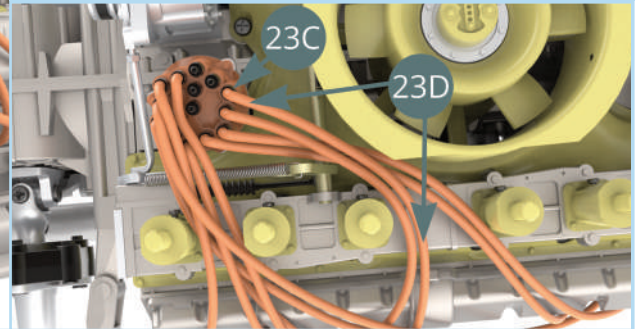

## STEP 12

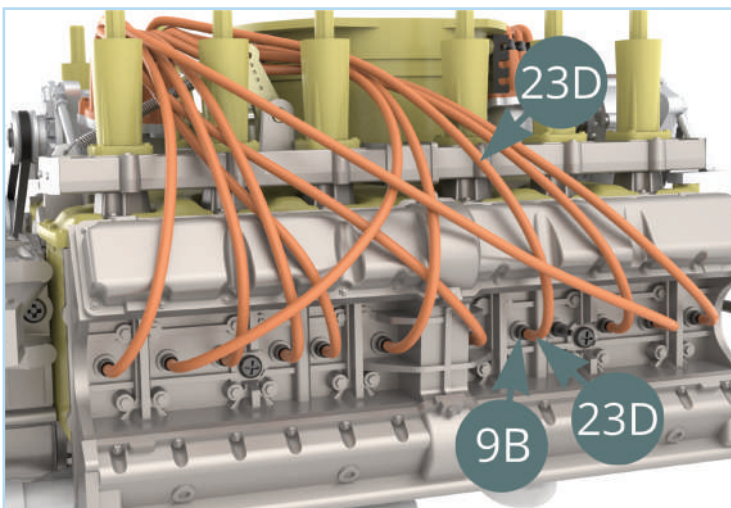

For the eleventh **plug lead (23D)** cut 10.5 cm in length. Attach it to the **spark plug (9B)** and **plug lead connector (23C)** shown.

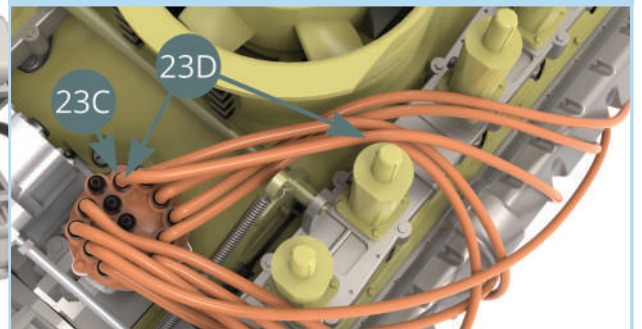

## STEP 13

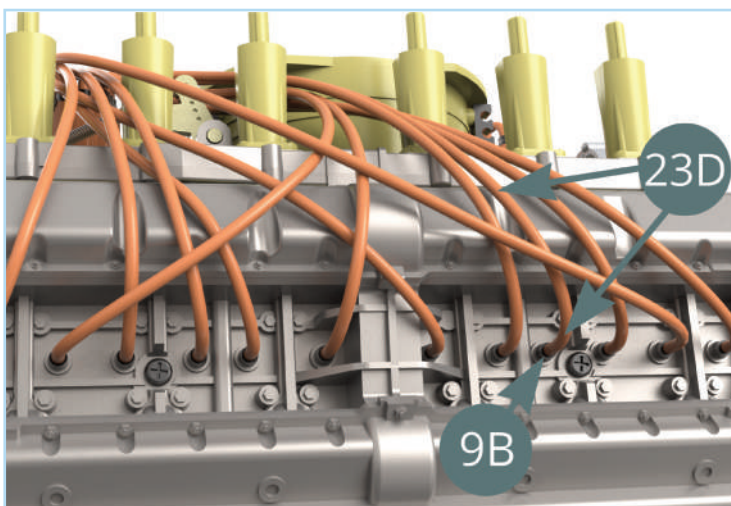

The twelfth **plug lead (23D)** is 11 cm in length. Attach it to the final **spark plug (9B)** and **plug lead connector (23C)**, leaving two connectors in the middle.

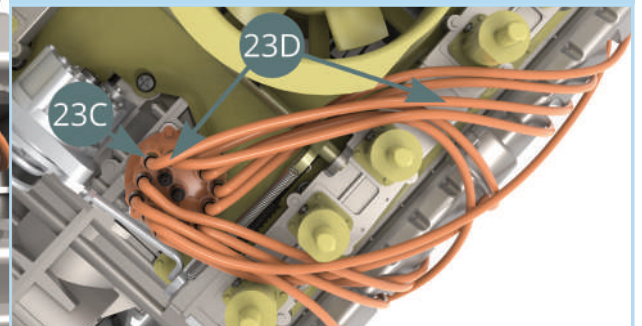



# STAGE 23: FITTING THE SECOND DISTRIBUTOR AND ATTACHING THE WIRES

STAGE COMPLETE

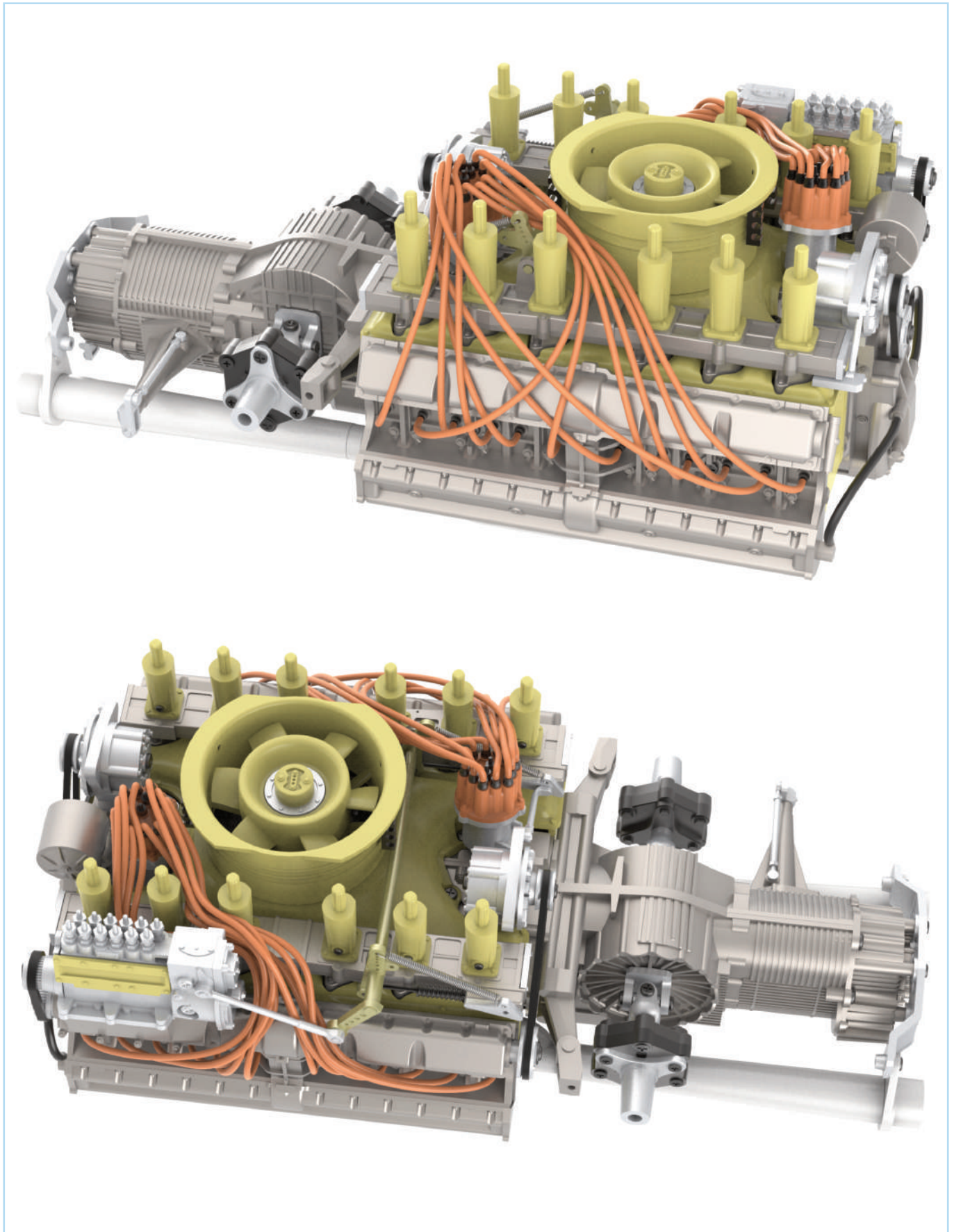



# STAGE 24: BRAKE FLUID TANKS AND WINDSCREEN WASHER RESERVOIR

**24A** V-frame

**24B** Collar link

**24C** Brake fluid tank

**24D** Brake fluid tank

**24E** Cap (x2)

**24F** Support

**24G** Brake fluid hose (x2)

**24H** Windshield washer reservoir

**24I** Windshield washer pump

**24J** Clip

**24K** Reservoir cap

**24L** Windshield washer fluid hose

**AP** Screw 1.7 x 4 mm (x2)

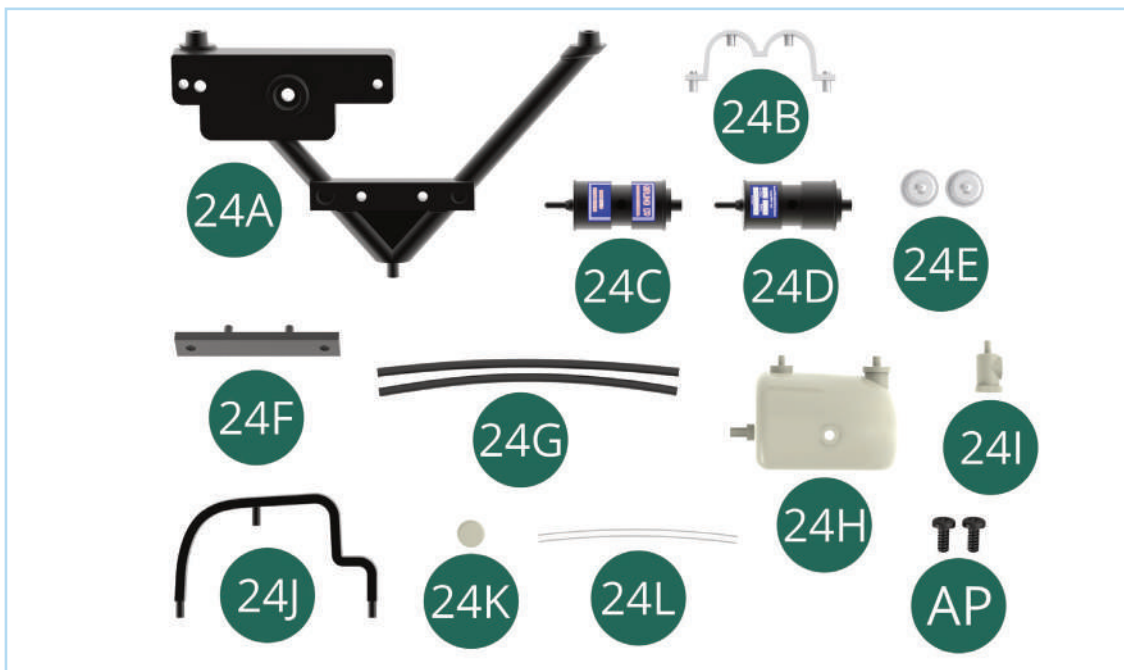

## ASSEMBLY DIAGRAM

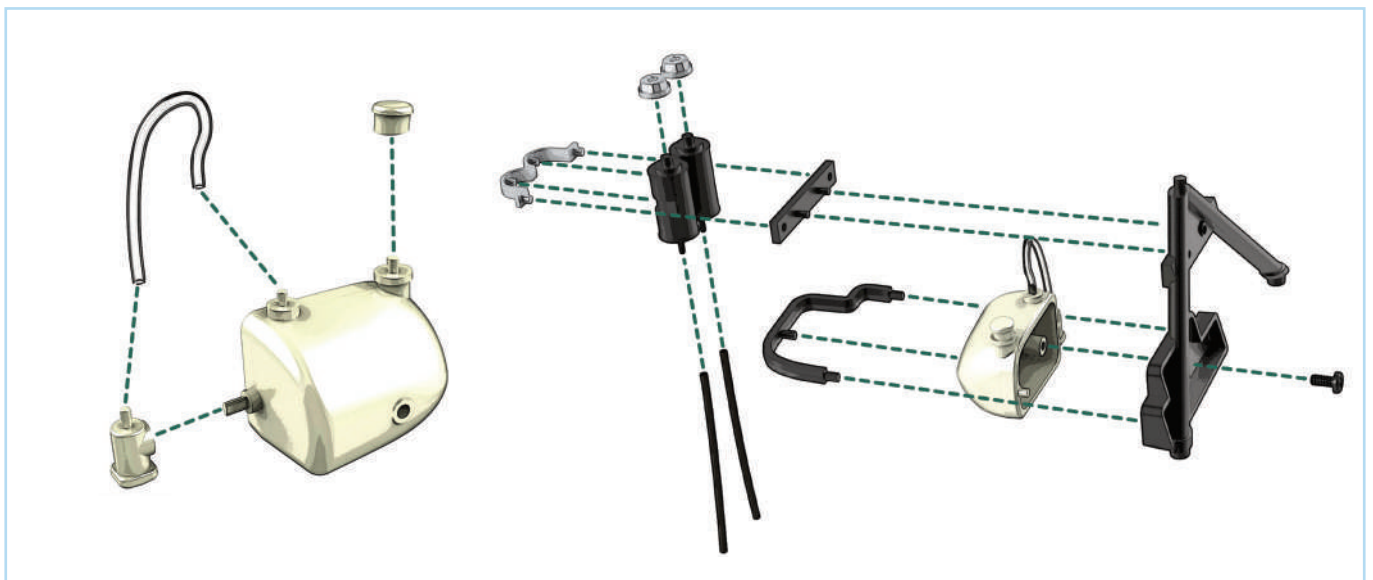

# STAGE 24: BRAKE FLUID TANKS AND WINDSCREEN WASHER RESERVOIR

## STEP 1

Fit the **reservoir cap (24K)** onto the **windshield washer reservoir (24H)**. Fit the **windshield washer pump (24I)** on the side of the reservoir, then connect the **washer fluid hose (24L)** onto the pins of the pump and reservoir.

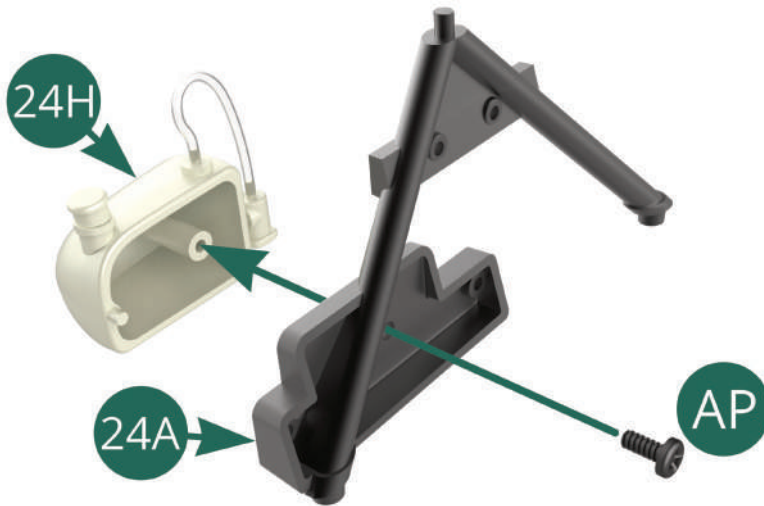
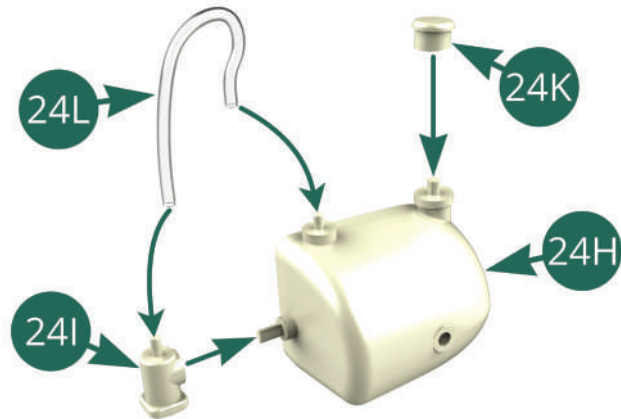

With the windshield washer reservoir assembled, fit it on the **V-frame (24A)** and secure in place using an **AP** screw.

Push the central pin of the **clip (24J)** into the hole in the reservoir and the outer pins into the corresponding holes in the V-frame.

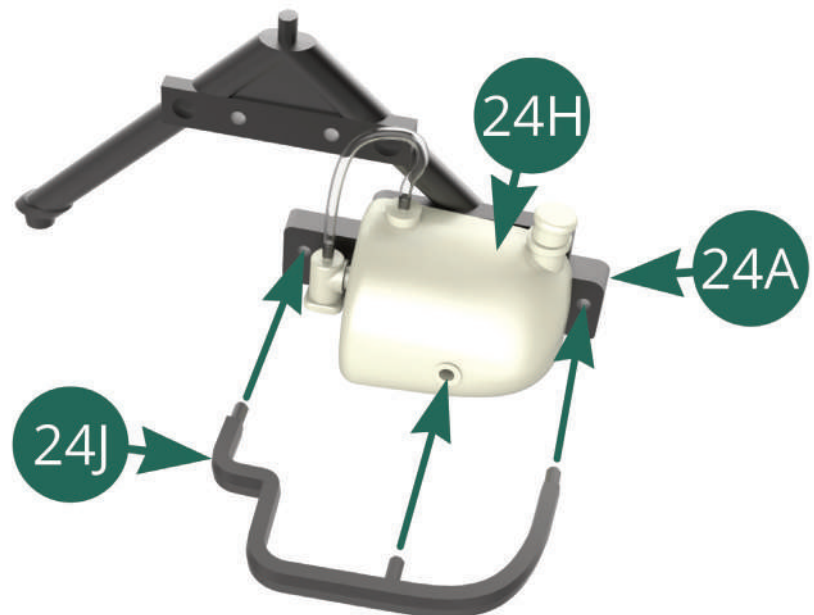



# STAGE 24: BRAKE FLUID TANKS AND WINDSCREEN WASHER RESERVOIR

## STEP 2

Take one of the **caps (24E)** and fit it onto the top of the **brake fluid tank (24C)**. Note this tank has a larger label than the other one (orange arrow).

Fit the **collar link (24B)** onto the tank as shown. The tank should be located on the left of the collar when looking face on.

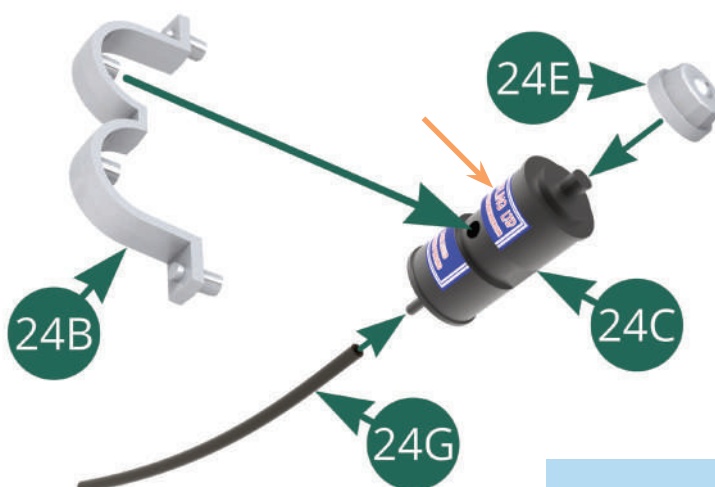

Attach the **brake fluid hose (24G)** onto the pin at the bottom of the tank.

Push the remaining **cap (24E)** onto the top of the other **brake fluid tank (24D)**.

Push the tank into the right side of the **collar link (24B)**, then attach the remaining **brake fluid hose (24G)** onto the pin at the bottom of the tank.

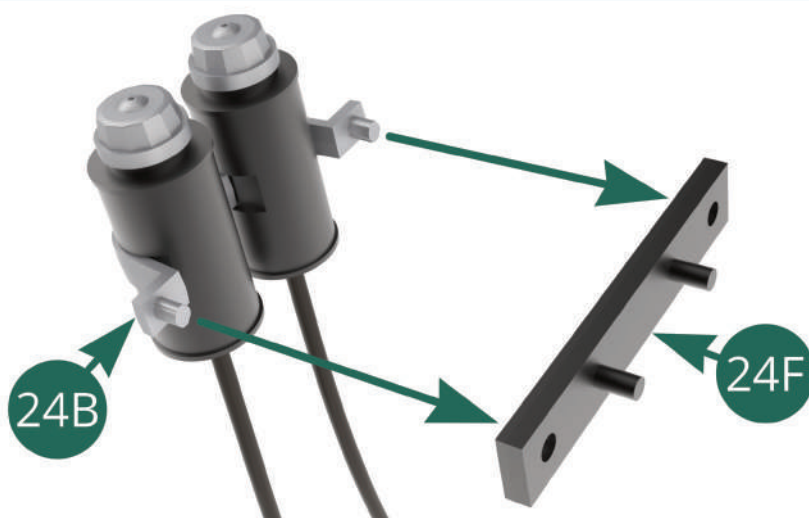
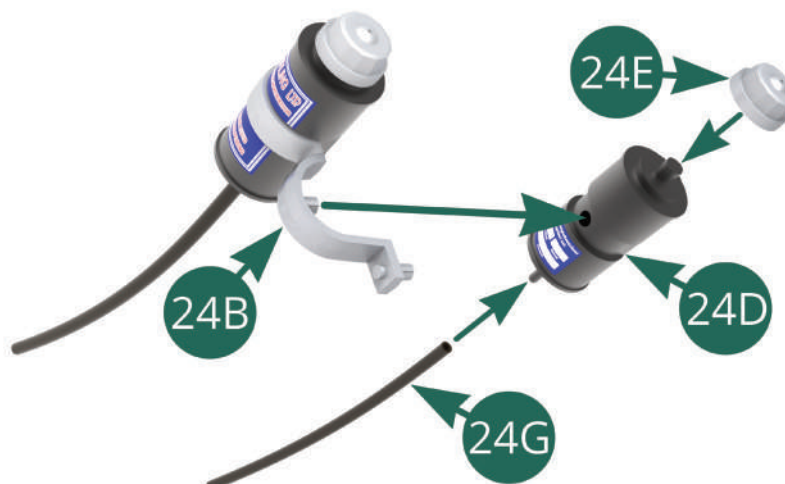

Now fit the **collar link (24B)** onto the **support (24F)** by pushing the pins of the collar through the holes in the support.

# STAGE 24: BRAKE FLUID TANKS AND WINDSCREEN WASHER RESERVOIR

## STEP 3

Finally, fit the brake fluid tanks in place next to the washer reservoir by pushing the pins on the **support (24F)** into the corresponding holes of the **V-frame (24A)**. Note the position brake fluid hose once the tanks have been fitted, shown opposite.

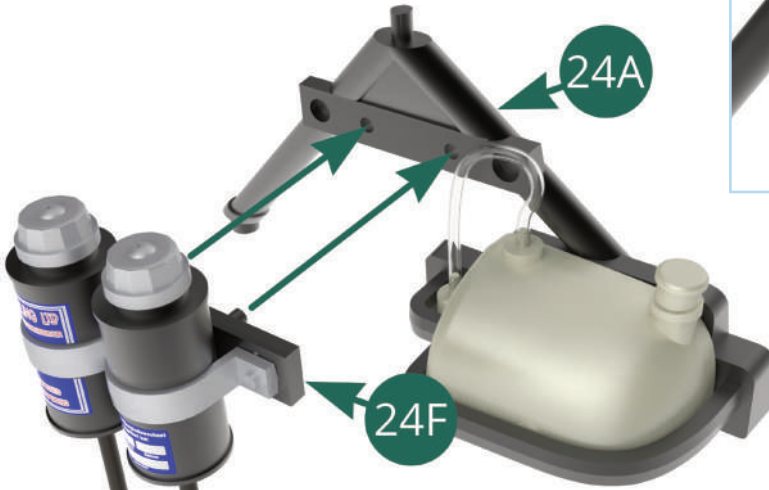

## STAGE COMPLETE





# STAGE 25: FIXING THE ENGINE MOUNT TO THE CHASSIS

25A Chassis

FM Screw 1.7 x 4 mm (x3)

25B Front engine mount

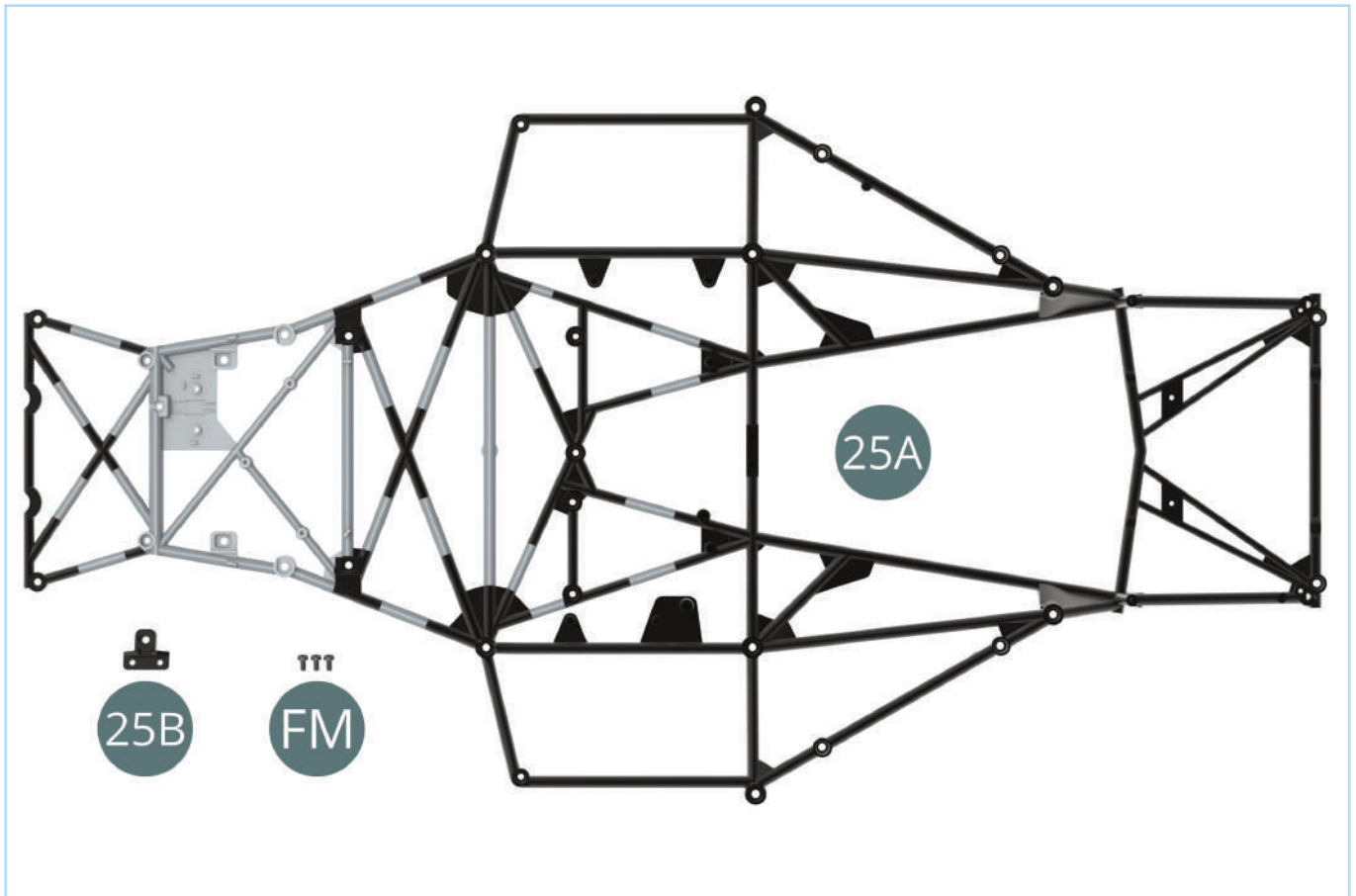

## ASSEMBLY DIAGRAM

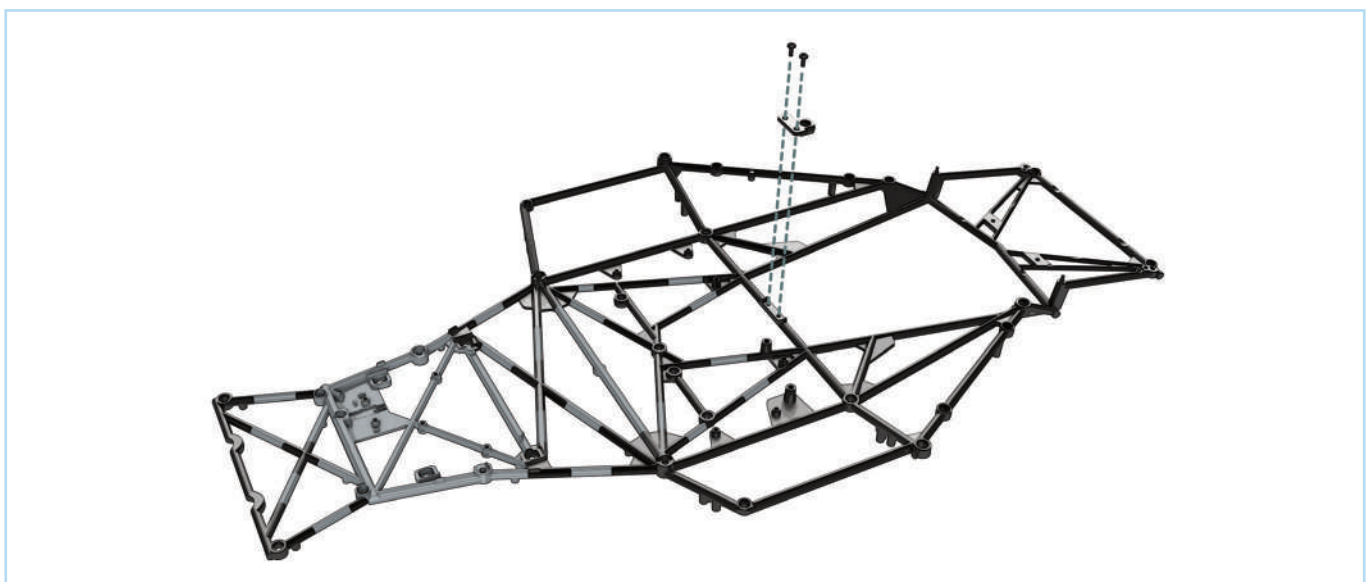

# STAGE 25: FIXING THE ENGINE MOUNT TO THE CHASSIS

## STEP 1

Fit the **front engine mount (25B)** on the **chassis (25A)** and fix in place using two **FM screws**.

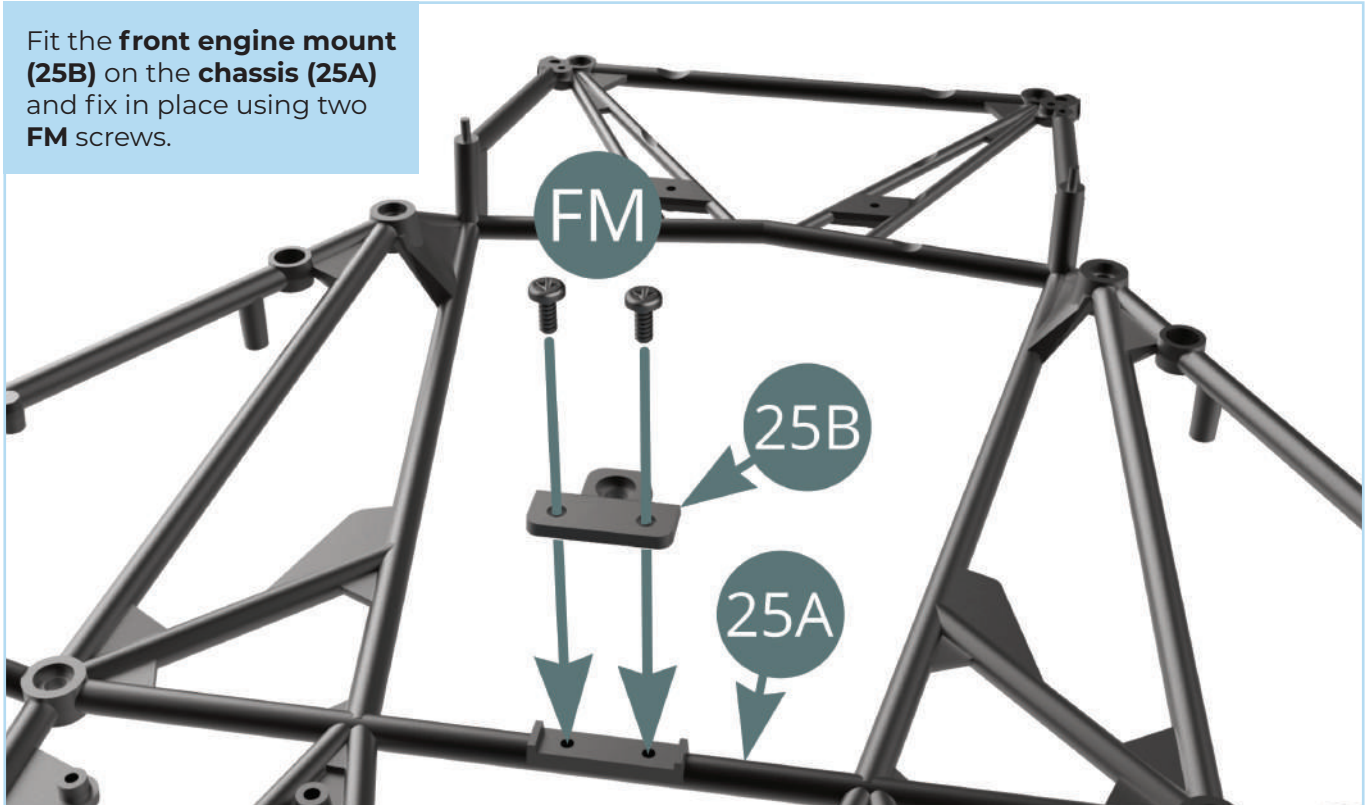



# STAGE 25: FIXING THE ENGINE MOUNT TO THE CHASSIS

STAGE COMPLETE

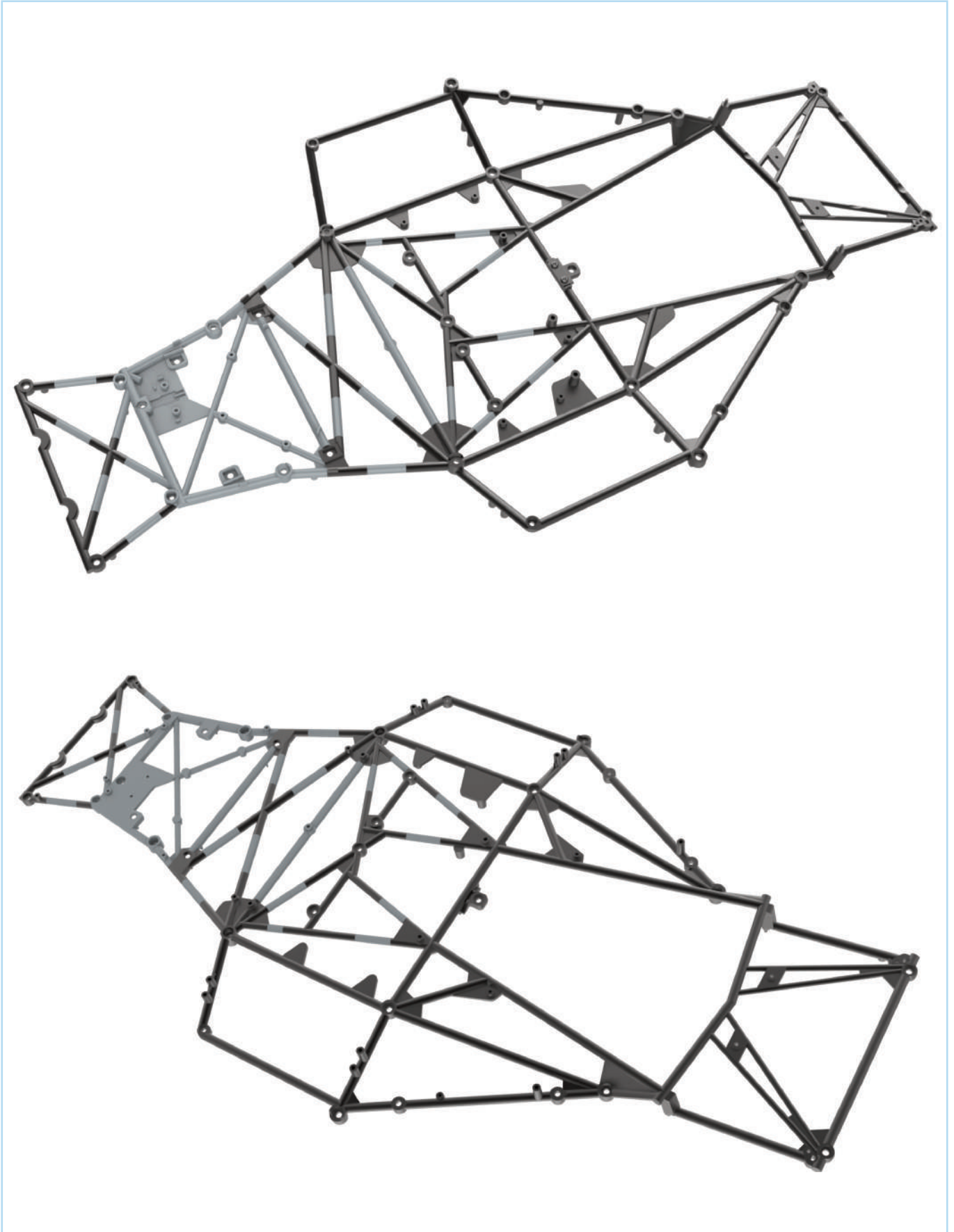

# STAGE 26: INSTALLING THE PEDALS AND FOOTREST ON THE CHASSIS

**26A** Footrest

**26B** Rod

**26C** Bottom bracket

**26D** Throttle pedal

**26E** Clutch pedal

**26F** Brake pedal

**26G** Pedal bracket

**26H** Master cylinders

**26I** Pushrod (x2)

**26J** Clutch cable

**26K** Brake light switch cable

**AP** Screw 1.7 x 4 mm (x2)

**GP** Screw 1.2 x 5 mm (x2)

**KP** Screw 1.2 x 9.5 mm (x2)

**IM** Screw 1.7 x 3.5 mm (x3)

**KM** Screw 1.7 x 3 x 5 mm (x3)

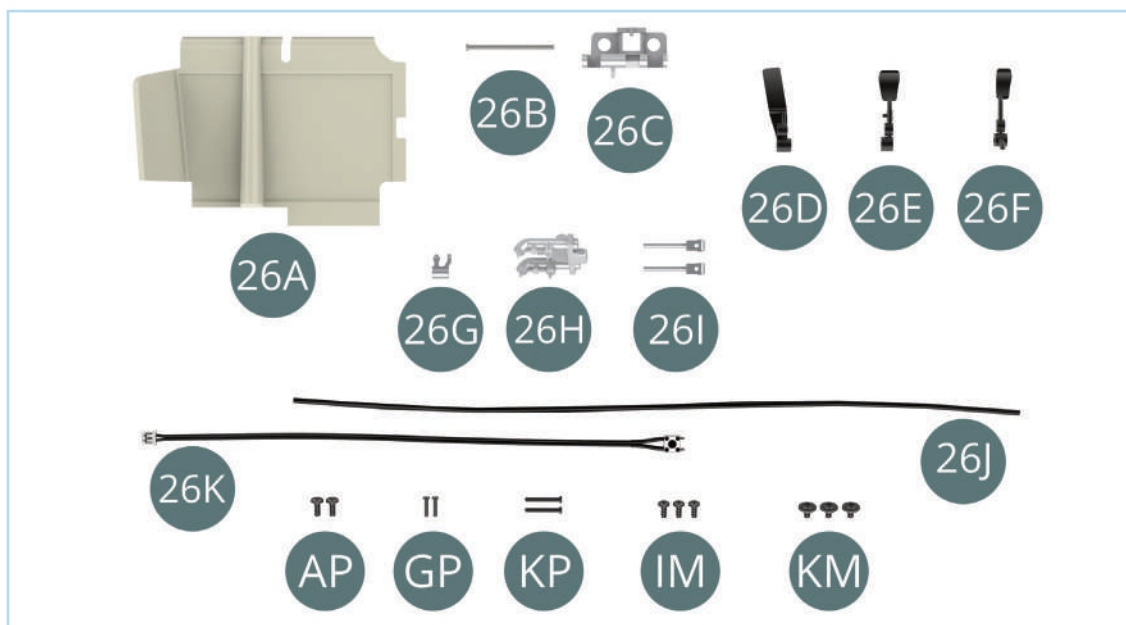

## ASSEMBLY DIAGRAM





# STAGE 26: INSTALLING THE PEDALS AND FOOTREST ON THE CHASSIS

## ASSEMBLY DIAGRAM

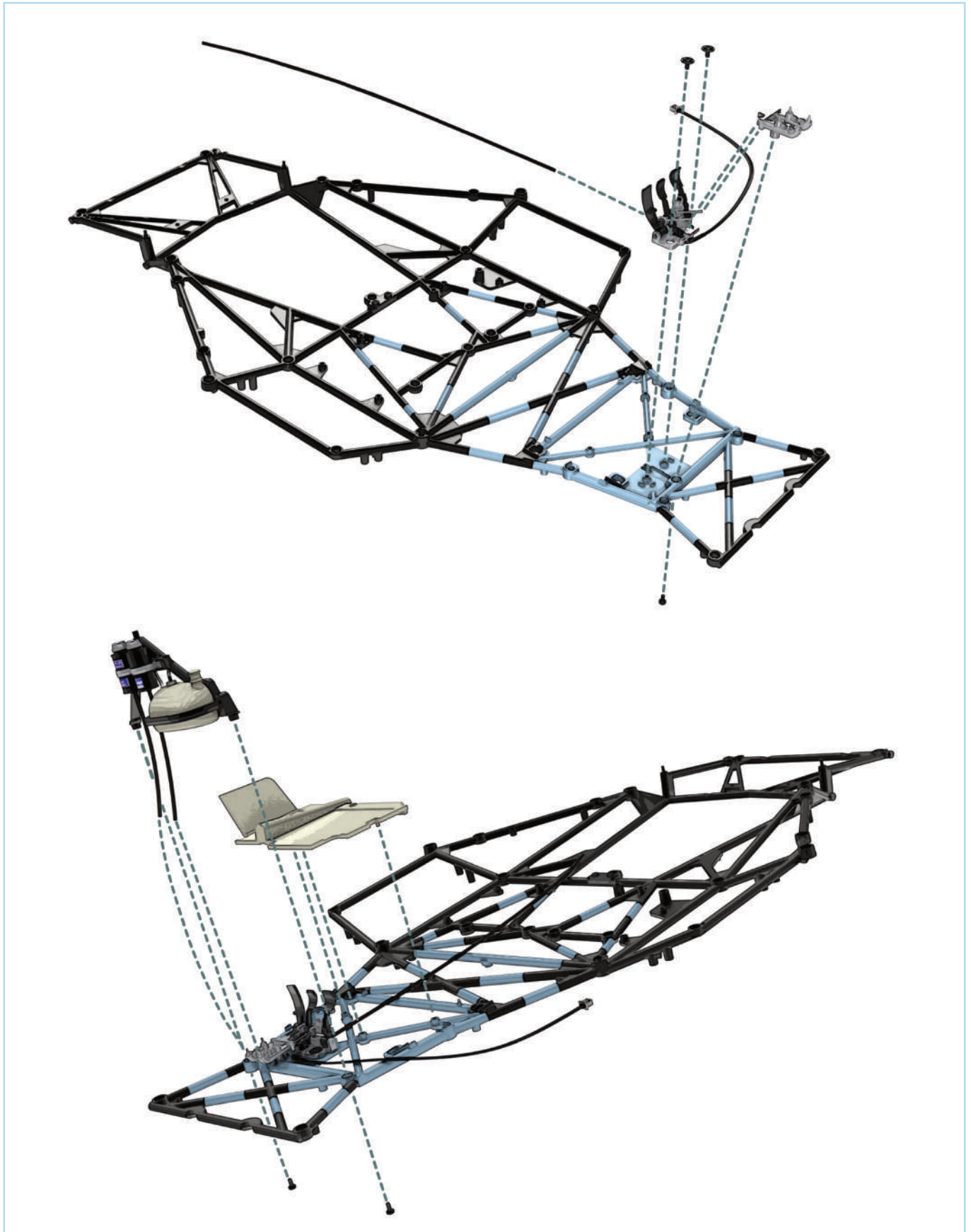

# STAGE 26: INSTALLING THE PEDALS AND FOOTREST ON THE CHASSIS

## STEP 1

Take the **clutch (26E)** and fit the pin on the side into the **bracket (26G)** as shown. Pass a **KP** screw through the clutch then the bracket and drive it into the larger hole of one of the **pushrods (26I)**. Make sure the pushrod is still able to rotate once fixed.

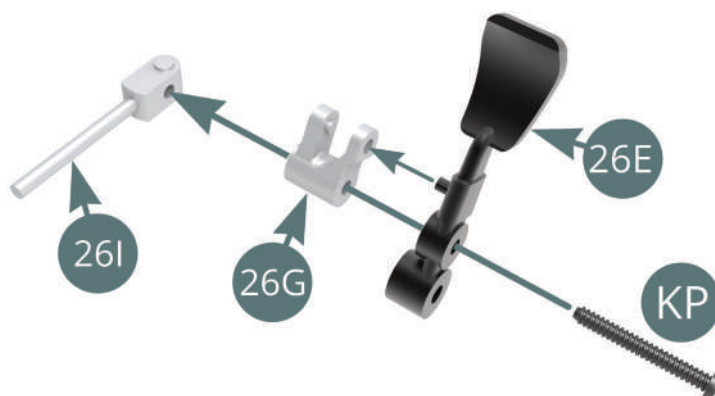

Fit a **GP** screw through the **throttle pedal (26D)** and fix into the other **pushrod (26I)**, again using the larger hole. Make sure the pushrod is still able to rotate once fixed.

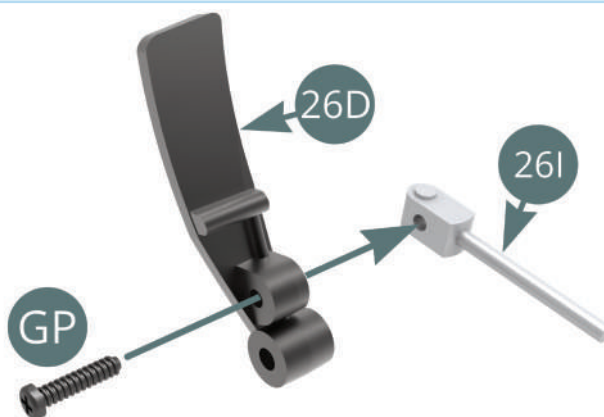

## STEP 2

First, align the **throttle pedal (26D)** with the **pedal bracket (26C)** and fit it in place. Push the **rod (26B)** partway through the hole in the bracket to hold the throttle pedal in place.

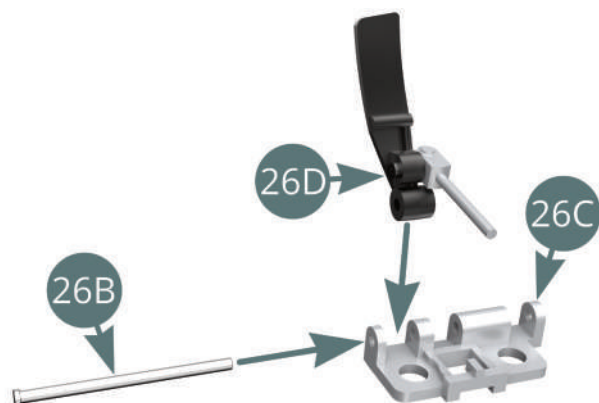

Position the **brake pedal (26F)** and the **clutch pedal (26E)** into the **pedal bracket (26C)** one after the other, pushing the **rod (26B)** further through to secure each in turn (blue arrow).

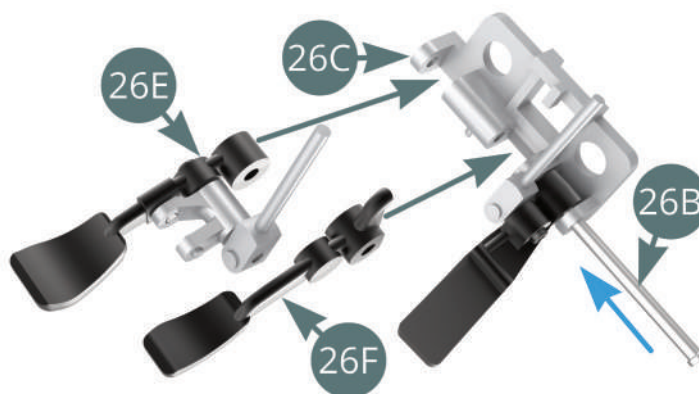



# STAGE 26: INSTALLING THE PEDALS AND FOOTREST ON THE CHASSIS

## STEP 3

Take the **brake light switch cable (26K)** and position the button end in the slot located under the **pedal bracket (26C)**. Fold the cable to the side as shown by the blue arrow.

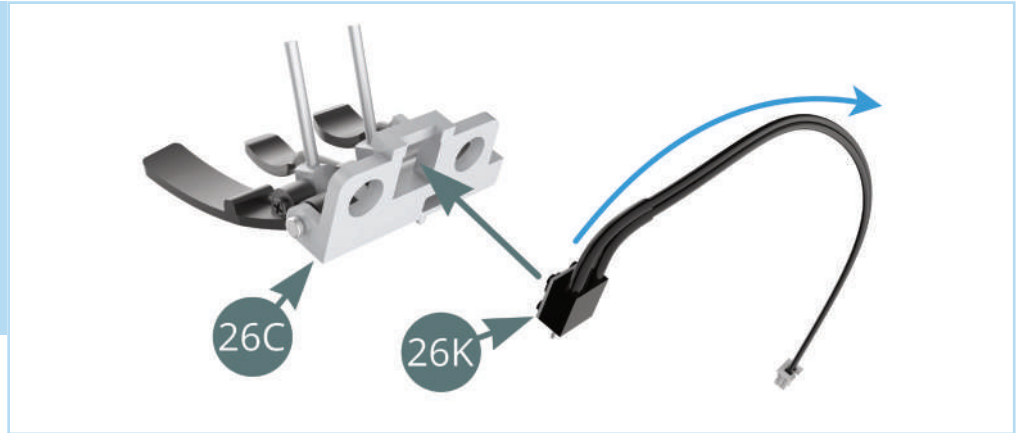

The pedal assembly should look like this.



## STEP 4

Fit the **pedal bracket (26C)** on the **chassis (25A)** then fix it in place using two **KM** screws.

Make sure the screws are tightened fully so that the button on the switch cable doesn't stay pressed when releasing the pedal.

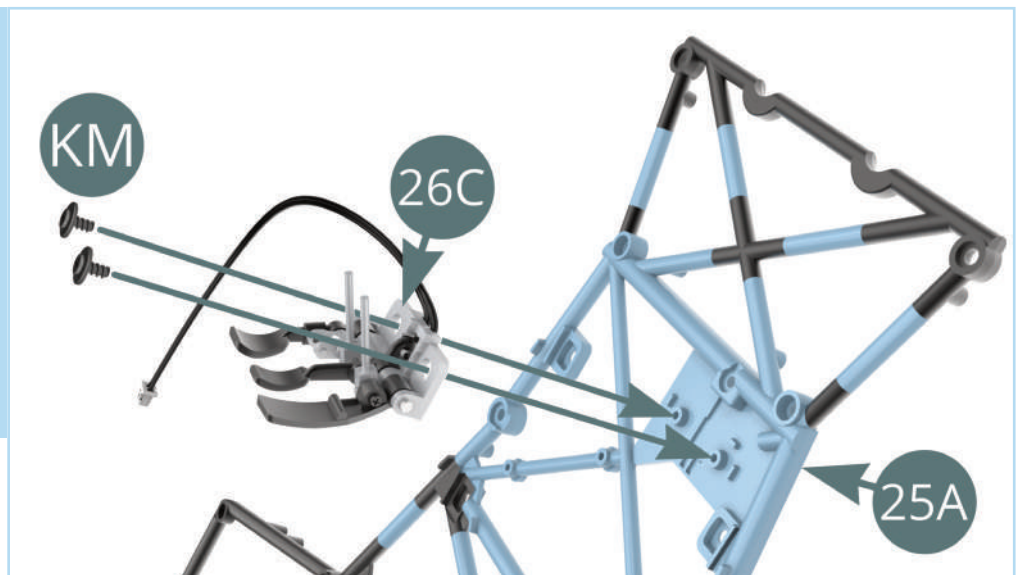

# STAGE 26: INSTALLING THE PEDALS AND FOOTREST ON THE CHASSIS

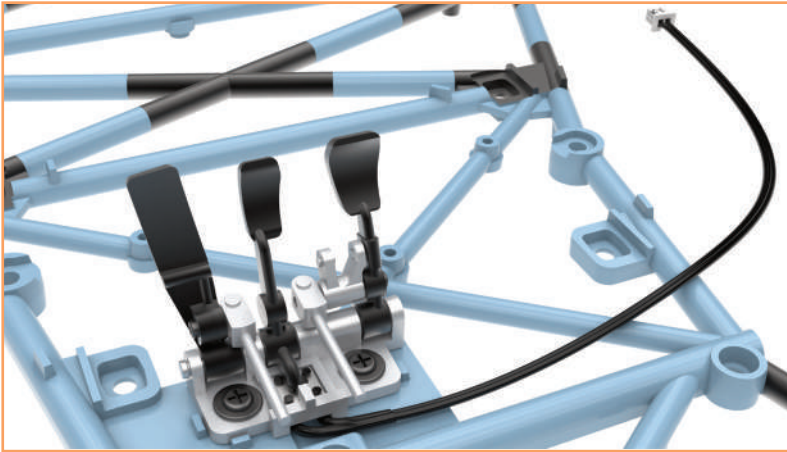

The crankset installed on the chassis.

## STEP 5

Position the **master cylinders (26H)** on the **chassis (25A)** and, at the same time, insert the two **pushrods (26I)** into their respective master cylinder housings (blue arrow).

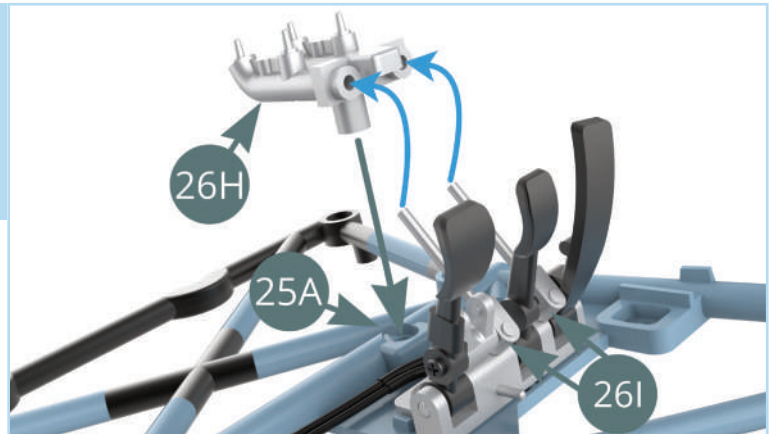

Secure the **master cylinders (26H)** in place by driving an **AP** screw into them from underneath the **chassis (25A)**.

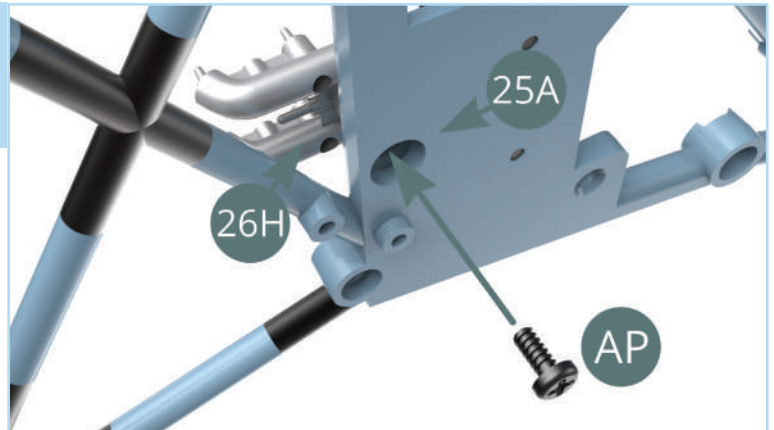

Fit one end of the **clutch cable (26J)** on the pin protruding from the **pedal bracket (26C)**.

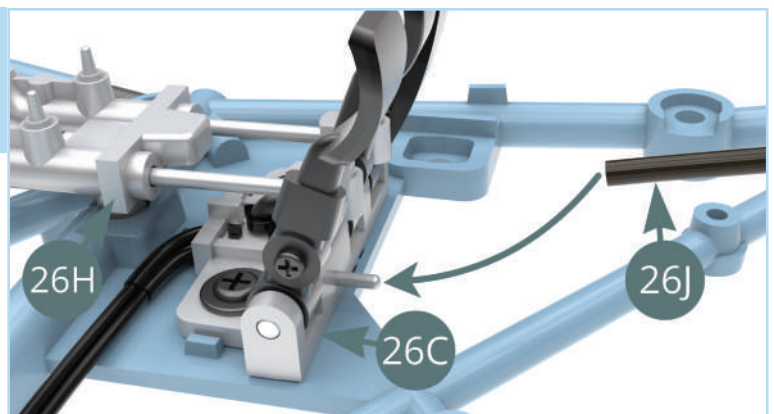



# STAGE 26: INSTALLING THE PEDALS AND FOOTREST ON THE CHASSIS

## STEP 6

Press the **footrest (26A)** onto the **chassis (25A)** using the three lugs as shown. At the same time, pass the **clutch cable (26J)** through the slot in the footrest as shown by the green arrow.

The two images below show how the clutch cable passes through the slot.

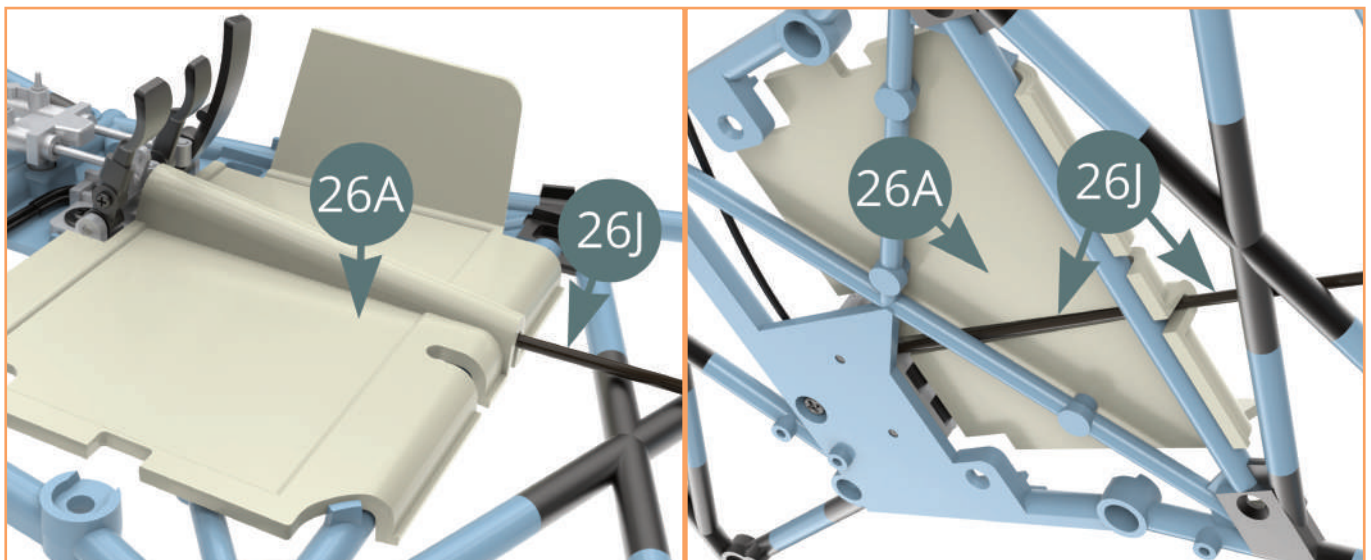
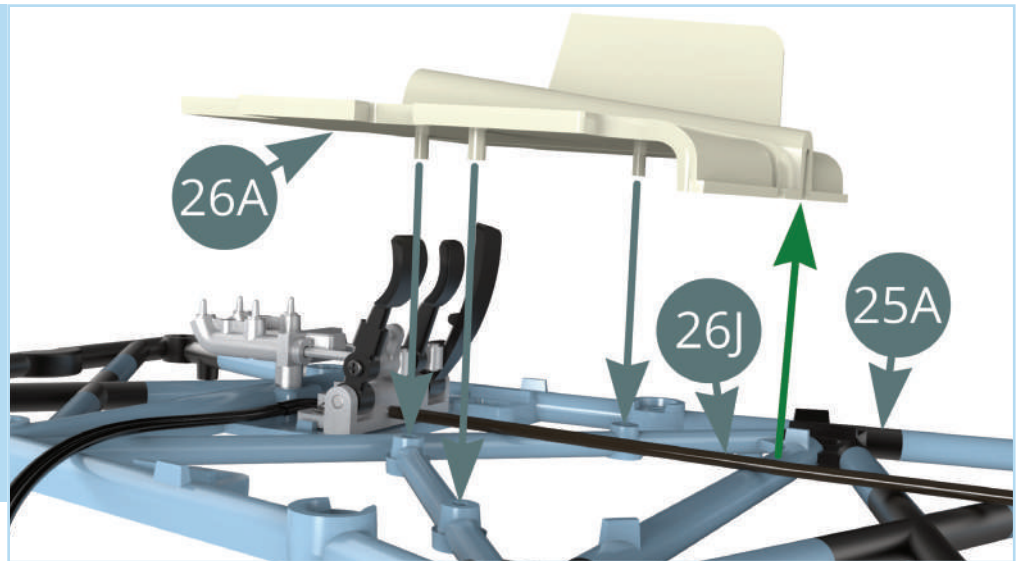

## STEP 7

Take the V-frame with the brake fluid tanks and washer reservoir from stage 24 and align it as shown with the chassis.

Plug the ends of the **brake fluid hose (24G)** nozzles over the pins at the front of the **master cylinders (26H)** (red arrows).

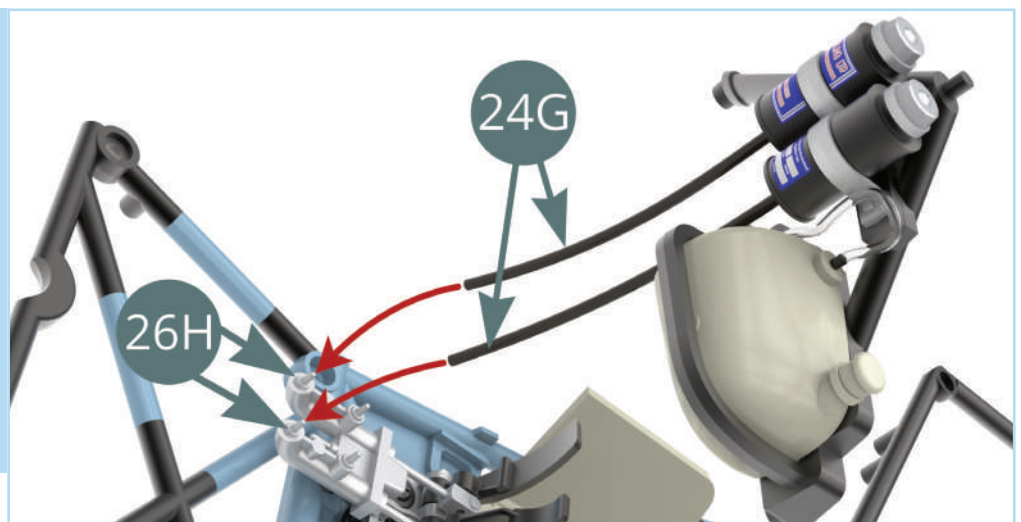

# STAGE 26: INSTALLING THE PEDALS AND FOOTREST ON THE CHASSIS

## STEP 8

Fit the **V-frame (24A)** on the **chassis (25A)** as shown.

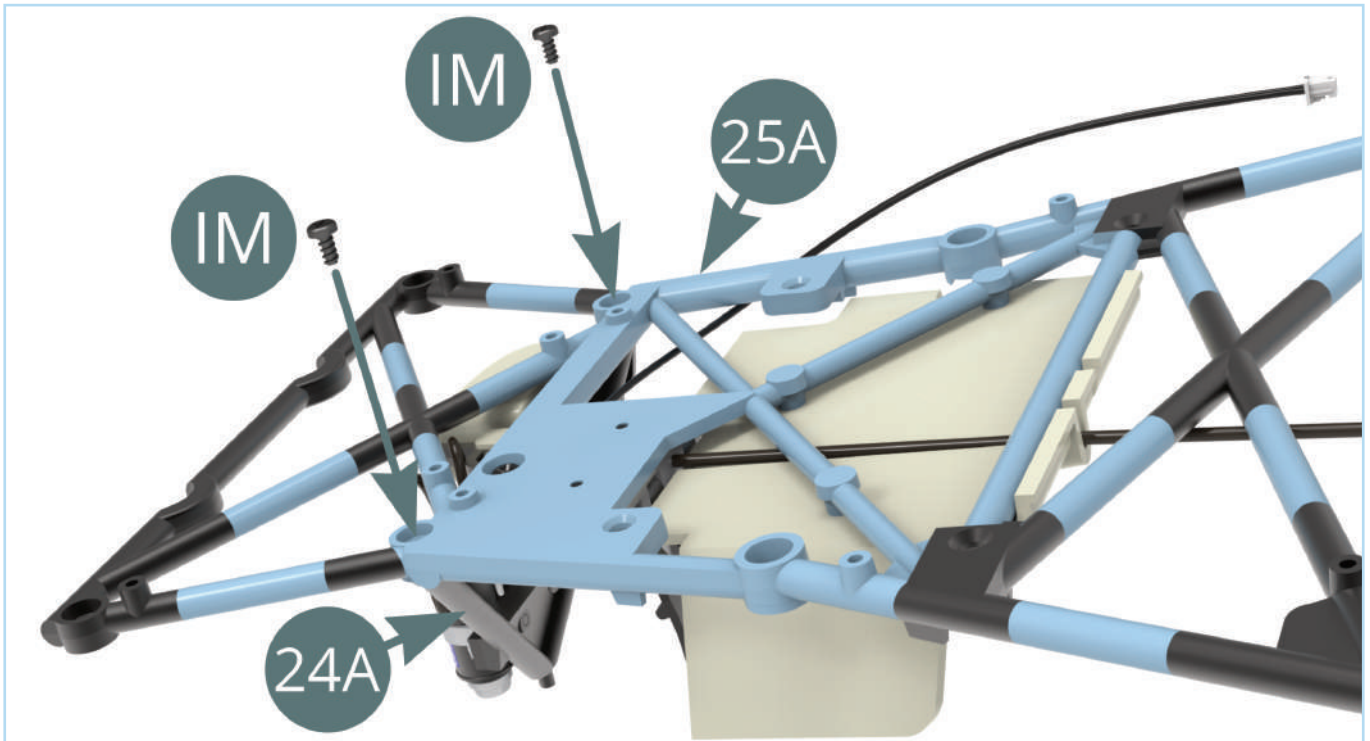
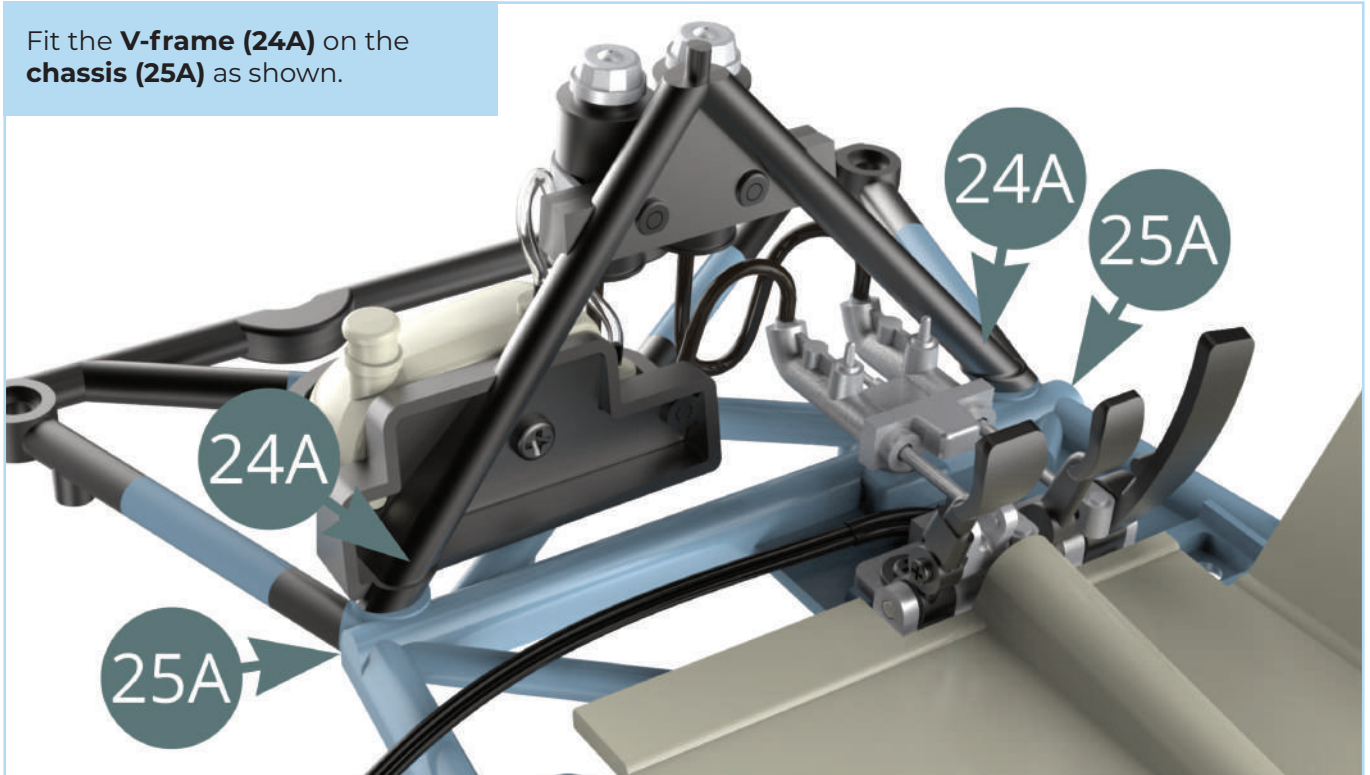

Carefully turn the chassis over and secure the V-frame to it using two **IM** screws.



# STAGE 26: INSTALLING THE PEDALS AND FOOTREST ON THE CHASSIS

STAGE COMPLETE

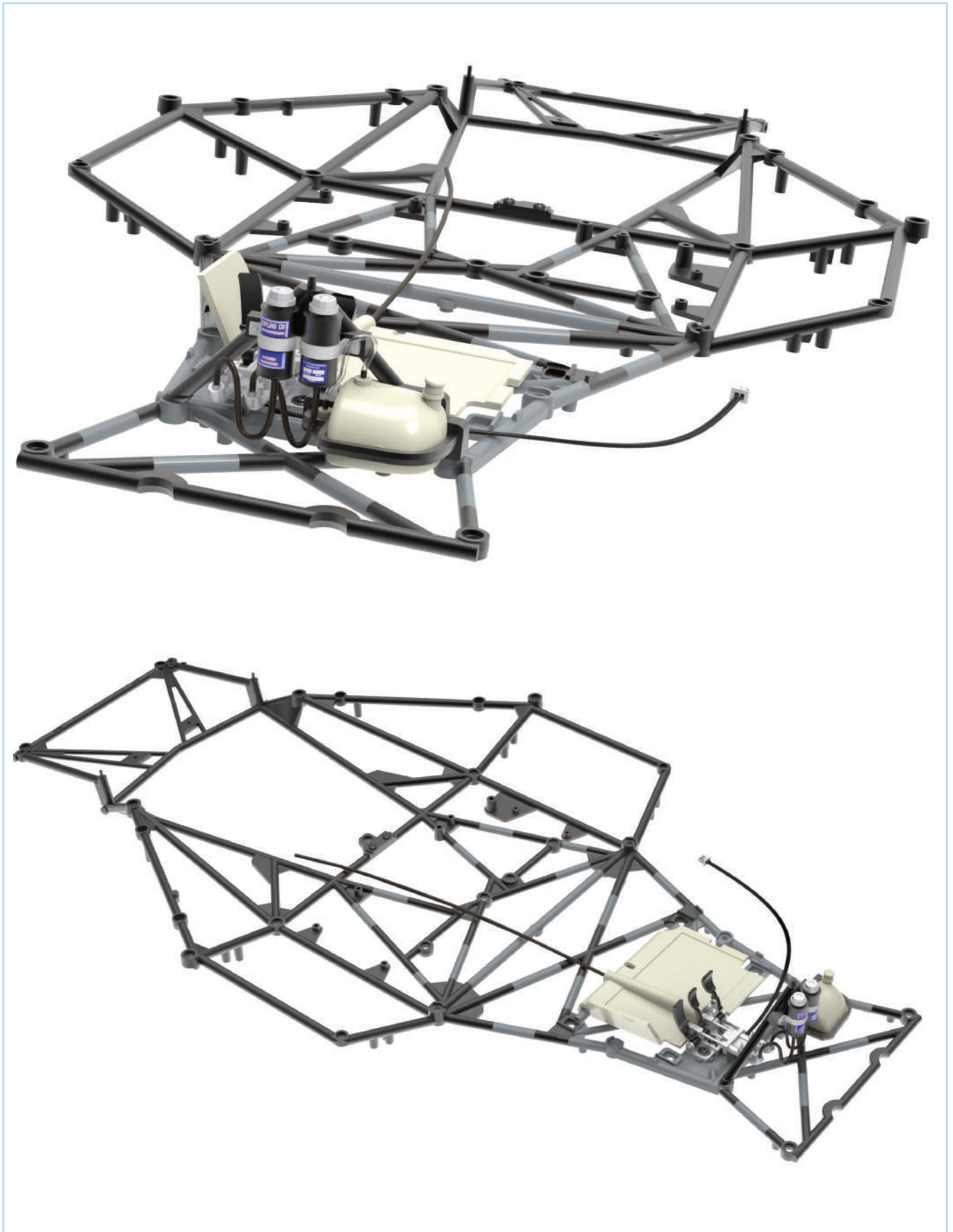

# STAGE 27: BUILDING THE DASHBOARD FRAME AND FITTING THE LEFT SUSPENSION

**27A** Dashboard frame

**27B** Plate bracket (x2)

**27C** Windscreen wiper control

**27D** Horn

**IM** Screw 1.7 x 3.5 mm (x2)

**BM** Screw 2 x 4 mm (x4)

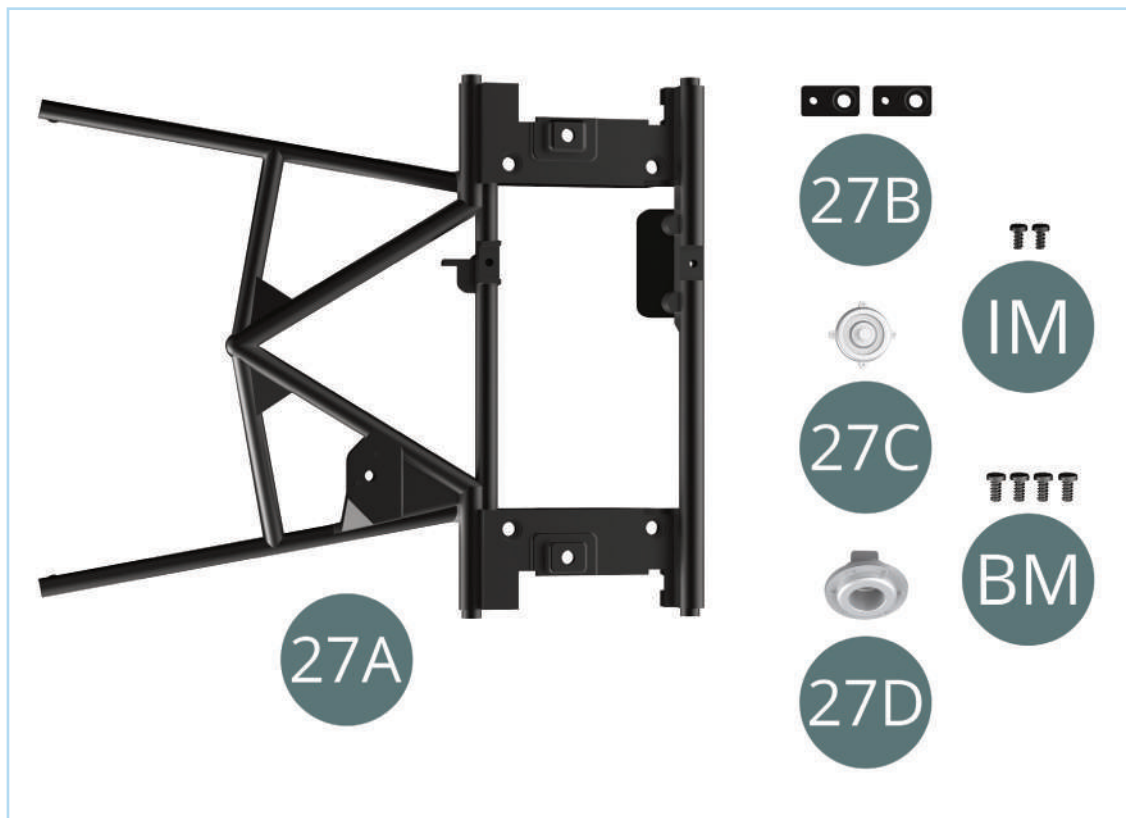

## ASSEMBLY DIAGRAM

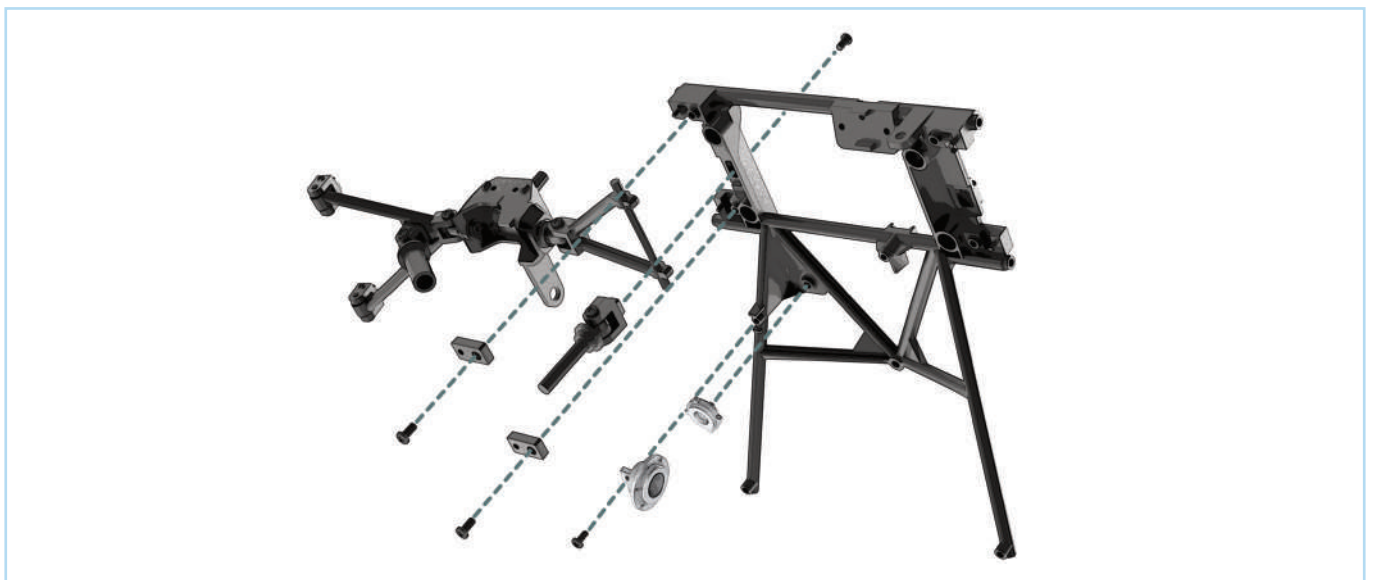



# STAGE 27: BUILDING THE DASHBOARD FRAME AND FITTING THE LEFT SUSPENSION

## STEP 1

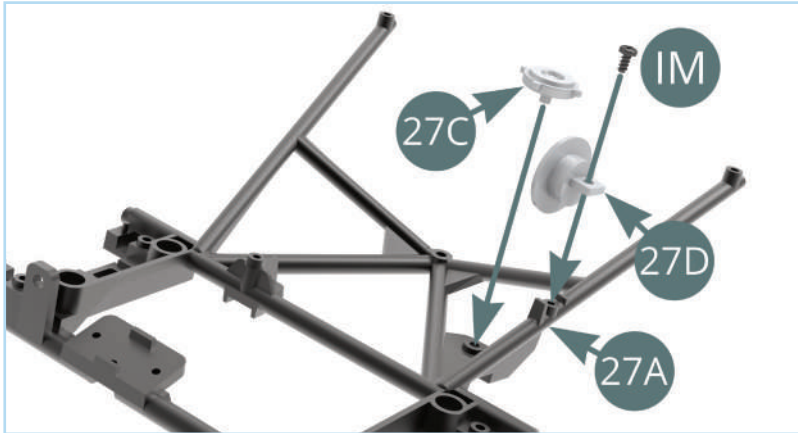

Press the **windscreen wiper control (27C)** into the **dashboard frame (27A)** as shown. Fit the **horn (27D)** in position on the frame then secure using an **IM** screw.

## STEP 2

Take the left front suspension assembly from stage 3. Fit the **upper control arm (3A)** into the **dashboard frame (27A)** as shown.



Attach the left front suspension assembly to the frame by fitting the two **plate brackets (27B)** over the upper control arm then securing each using a **BM** screw.

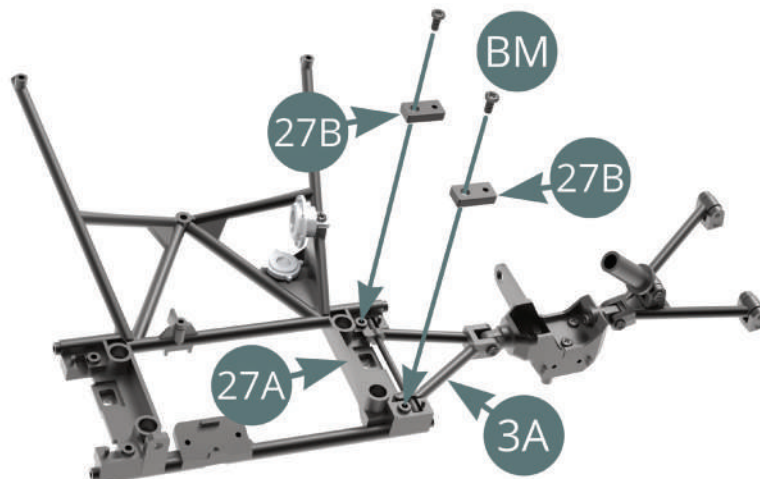

Tip: use a drop of oil on the thread of the screws to make it easier to drive them in.

# STAGE 27: BUILDING THE DASHBOARD FRAME AND FITTING THE LEFT SUSPENSION

## STEP 3

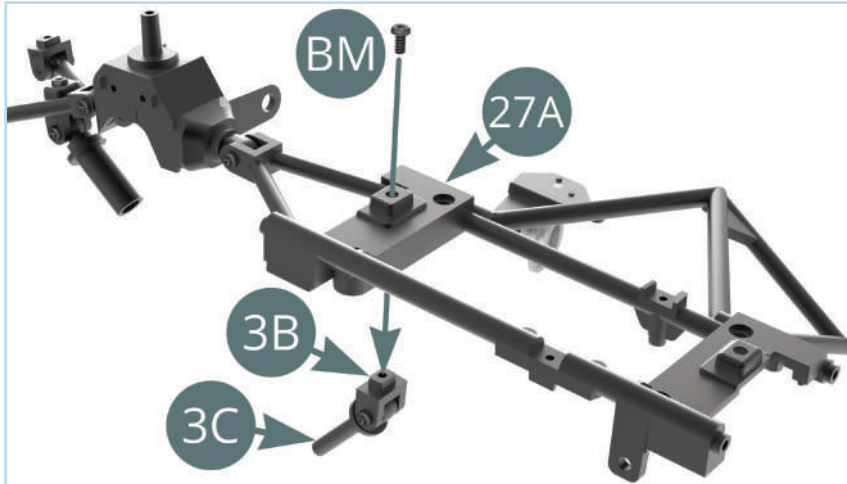

Retrieve the shock absorber piston assembly and fit the **upper bracket (3B)** into the socket in the **dashboard frame (27A)**. Fix the bracket using a **BM** screw.

## STAGE COMPLETE





# STAGE 28: INSTALLING THE STEERING WHEEL ON THE DASHBOARD FRAME

**28A** Attachment

**28B** Support

**28C** Support

**28D** Attachment

**28E** Fire extinguisher pull

**AP** Screw 1.7 x 4 mm (x3)

**IM** Screw 1.7 x 3.5 mm (x5)

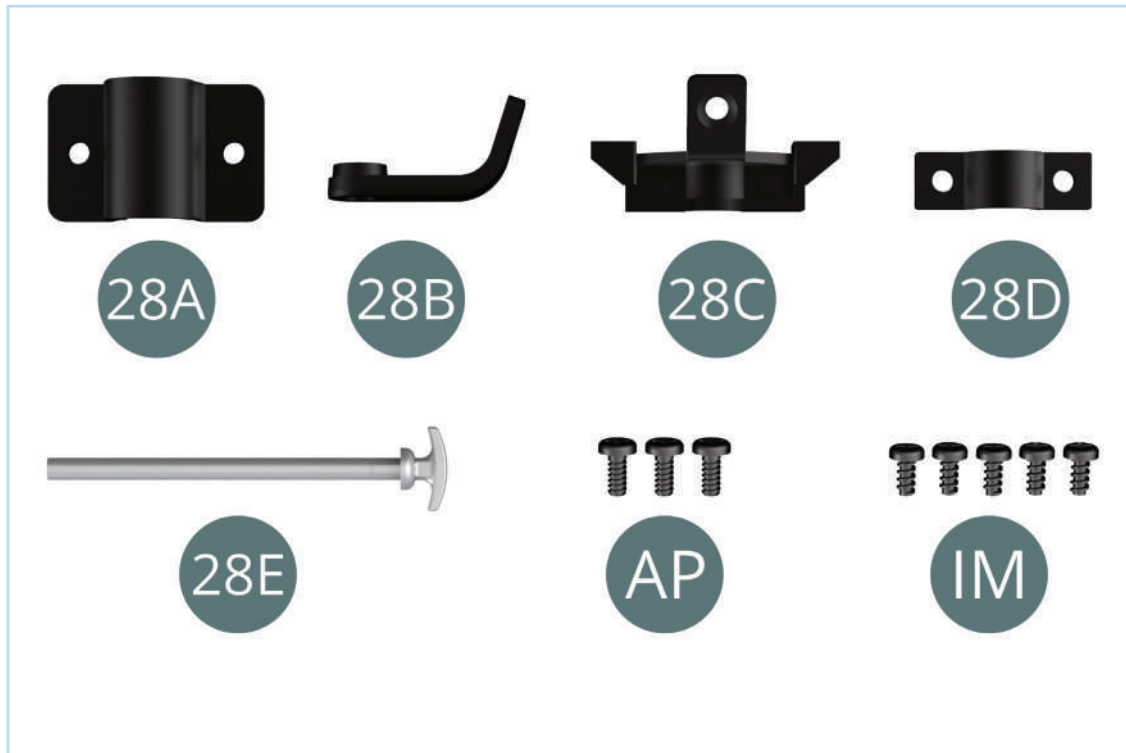

## ASSEMBLY DIAGRAM

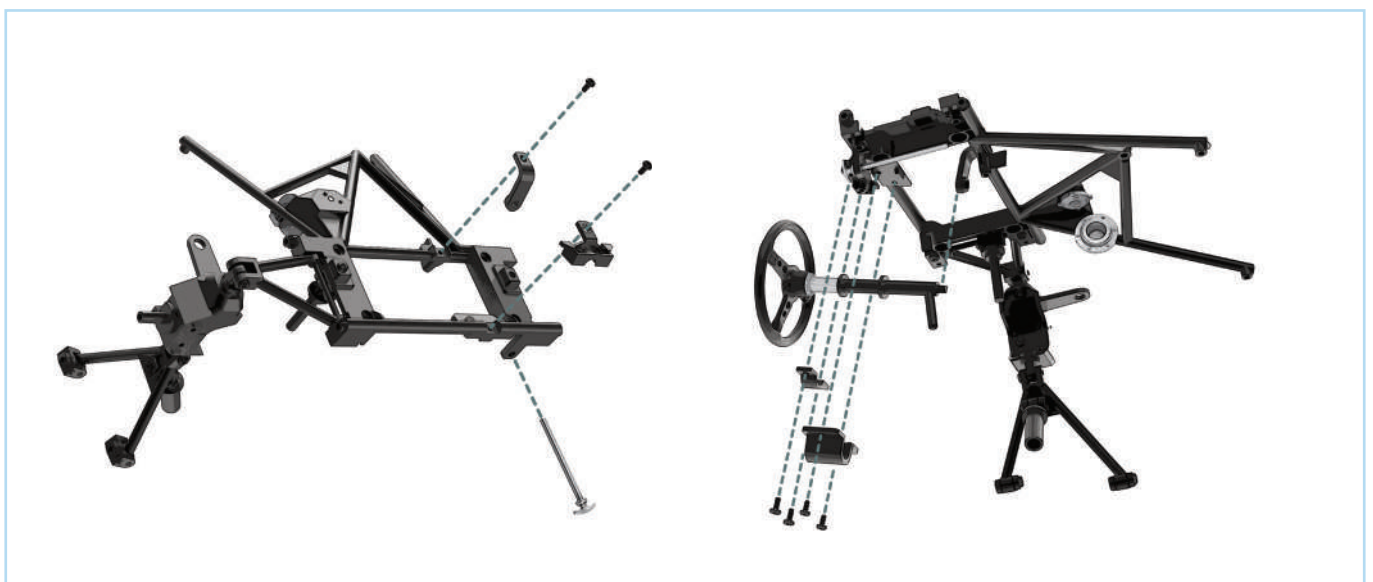

# STAGE 28: INSTALLING THE STEERING WHEEL ON THE DASHBOARD FRAME

## STEP 1

Take the **dashboard frame (27A)**. Fit the **support (28B)** to it as shown then secure using an **IM** screw.



Tip: use a drop of oil on the thread of the screw to make it easier to drive it in.

Attach the **support (28C)** opposite the previous one and fix it to the frame using an **IM** screw.



## STEP 2

Push the **fire extinguisher pull (28E)** through the hole in the tab of the **dashboard frame (27A)** until the lip of the pull (red arrow) is flush with the tab.

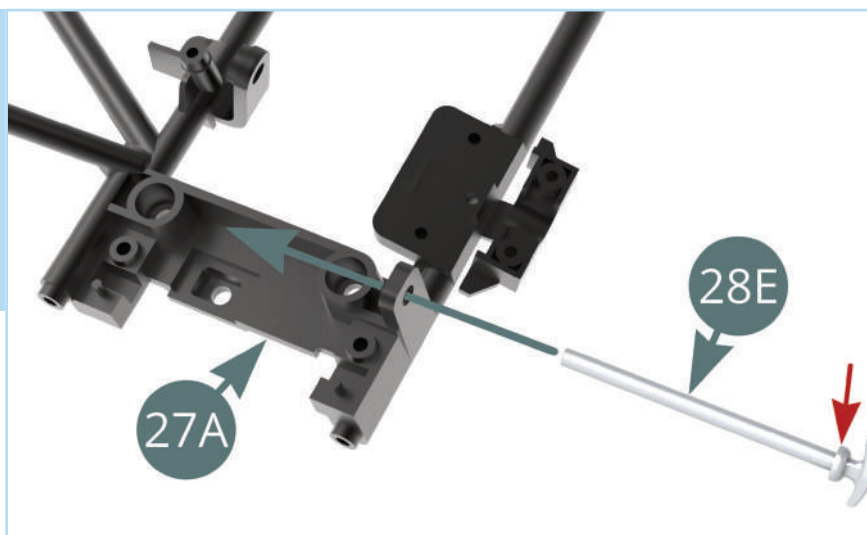

# STAGE 28: INSTALLING THE STEERING WHEEL ON THE DASHBOARD FRAME

## STEP 3

Retrieve the steering wheel assembly from stage 2. Position the end of the **steering column (2B)** on the **support (28B)** (blue arrow). Next, fit the **attachment (28D)** to the **support (28C)** using two **AP** screws.

Check that the axle at the end of steering column is oriented correctly (red arrow).

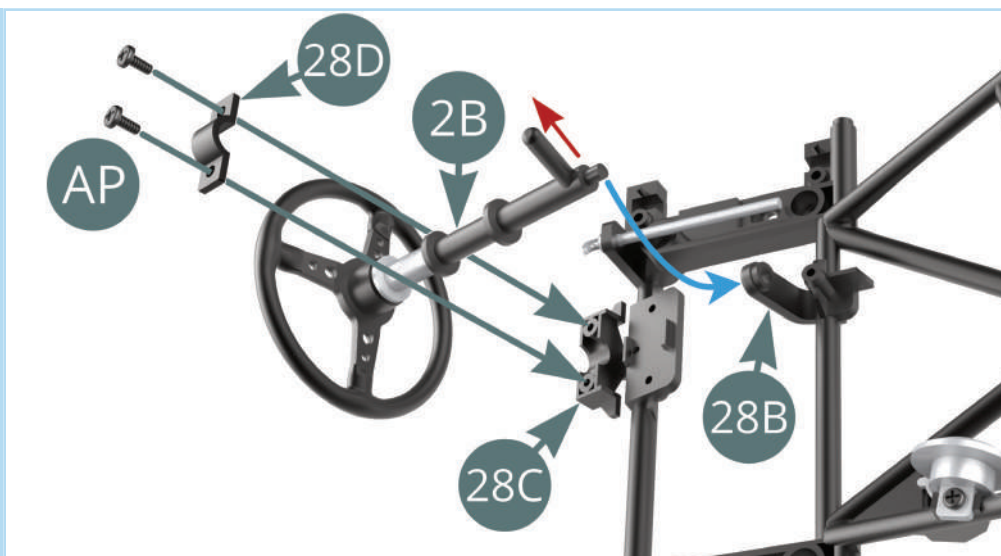

## STEP 4

Finally, fit the **attachment (28A)** over the steering column and secure it to the **dashboard frame (27A)** using two **IM** screws.

Tip: use a drop of oil on the thread of the screws to make it easier to drive them in.

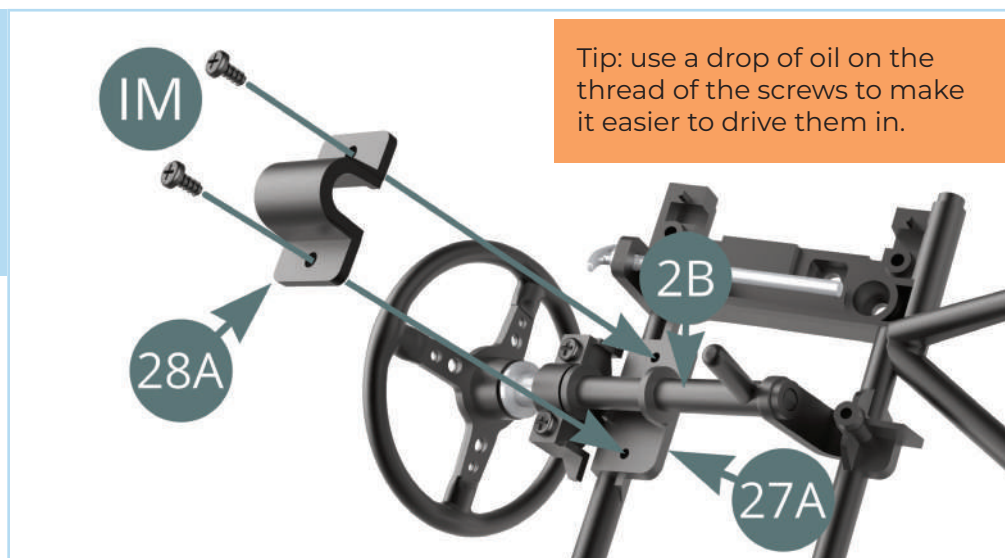



# STAGE 28: INSTALLING THE STEERING WHEEL ON THE DASHBOARD FRAME

STAGE COMPLETE

